

Barcode Dock Mount - BARCHLD2

Quick Installation and Maintenance Instructions



BARCDHLD2-(M/F/A/E25/R125/RMC/V/D/G/S/LCD)

Medical Facility Responsibility

Preventive maintenance checks must be performed regularly to maintain the quality and performance of this product. Any parts that may be broken, missing, worn, distorted or contaminated in any way should not be used and all affected parts should be replaced immediately. Should the necessity of any repair be suspected; please contact your local Amico distributor.



WARNING: This Quick Installation Guide is not a replacement for the full manual. It is the responsibility of the end user to ensure all aspects of the installation are covered by following the full manual and reviewing warnings/notes found at: <https://docs.amico.com/amico-aa-barcode-dock-mounts-manual.pdf>.

Installation Tool

Only applicable for configuration "BARCDHLD2-M".

HEX KEY: 1/8"

#2 PHILIPS SCREWDRIVER

Installation Reference

BARCDHLD2-M

Expansion Plate & Hardware Kit Envelop

Pre-installation Information

Determine the preferred orientation of the barcode charging base and refer to the below illustrations for mounting. Note the illustrations shown may not portray the configuration purchased. Use this guide as a reference to pair hardware and mounting hole pattern with respective barcode scanner base (not provided).

| | | |
|--|---|---|
| <p>H-FHMS-440-114 H-WLM-08 2 X H-WLM-08 2 X H-ANUT-440</p> | <p>2 X H-WLM-08 2 X H-MPP-0805-SS</p> | <p>4 X H-PHMS-M4-14 2 X H-PHMS-M4-14 2 X H-PHMS-M4-16 4 X H-WLM-08 4 X H-ACNUT-8-32</p> |
| <p>Barcode charging base with 1 hole, such as Honeywell 2020 for barcode scanners: 3820, 4620, 4820, or 5620</p> | <p>Barcode charging base with 2 holes, such as Honeywell CCB01-010BT for the Honeywell Xenon 1900, 1910, 1902, 1912</p> | <p>Barcode charging base with 4 holes, such as code reader CRA-A101 or CRA-A104 for CR2600</p> |

Installation to Device

- Before mounting the barcode scanner onto the mounting plate, determine the mounting pattern on the barcode scanner base. If the barcode scanner base is too large to mount onto the **BARCODE SCANNER HOLDER**, proceed to step 2 for installation of secondary plate.

If the secondary extension plate is required, determine the preferred orientation (refer to section 2: Pre-installation Instructions) and secure by inserting 2x or 3x **H-FHMS-832-12** through the **EXTENSION PLATE**, **BARCODE SCANNER HOLDER**, 2x or 3x **STEEL LOCK WASHERS**, 2x or 3x **ACORN NUTS**, ensuring that the **MOUNTING SCREWS** do not interfere with the mounting pattern of the **BARCODE SCANNER BASE**.

EXTENSION PLATE (OPTIONAL) [X-BRCDHLD-PLT]
2 X FLATHEAD SCREW [H-FHMS-832-12]
BARCODE SCANNER HOLDER [X-BRCDHLD-LBKT]
2 X H-WLM-08
2 X ACORN NUT [H-ACNUT-8-32]
3 X FLATHEAD SCREW [H-FHMS-832-12]
3 X H-WLM-08
3 X ACORN NUT [H-ACNUT-8-32]

Barcode Dock Mount - BARCHLD2

Quick Installation and Maintenance Instructions



BARCDHLD2-(M/F/A/E25/R125/RMC/V/D/G/S/LCD)

Installation to LCD

1. Slide the LCD SHELF ARM to desired position and tighten 2x HEX NUTS. Insert and tighten 2x NYLON LOCK NUTS to lock the LCD SHELF ARM in place. Cover the exposed NUTS with 2x HEX BOLT NUTS AND CAPS.
2. Loosely insert 2x 16 mm PANHEAD SCREWS through the top of two holes of the MONITOR HANDLE BODY and into the MONITOR (not provided). If the mounting pattern is recessed in the MONITOR, place 4x NYLON STANDOFFS between the MONITOR HANDLE BODY and the MONITOR, and use the 20 mm MACHINE SCREW instead of the 16 mm PANHEAD SCREW.
3. Slide 2x 12 mm PANHEAD SCREWS into the U-NOTCHES on the LCD VESA PLATE (not provided). Insert another 2x 12 mm PANHEAD SCREWS into the 2x BOTTOM HOLES of the LCD VESA PLATE, MONITOR HANDLE BODY, and into the MONITOR.
4. Tighten 4x 12 mm PANHEAD SCREWS in a cross pattern.

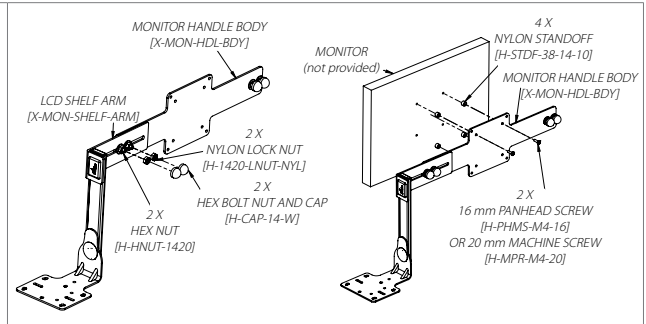

Adjustments (For LCD)

To adjust the BARCDHLD2-LCD, remove 2x HEX BOLT NUTS AND CAPS, 2x NYLON LOCK NUTS and loosen 2x HEX NUTS.
Slide LCD SHELF ARM to the desired location and re-tighten 2x HEX NUTS and 2x NYLON LOCK NUTS.

⚠ WARNING: In AHM ARM(s) with extensions, both arms have a 180° rotation. Ensure proper clearance around the arm(s) to avoid collision.

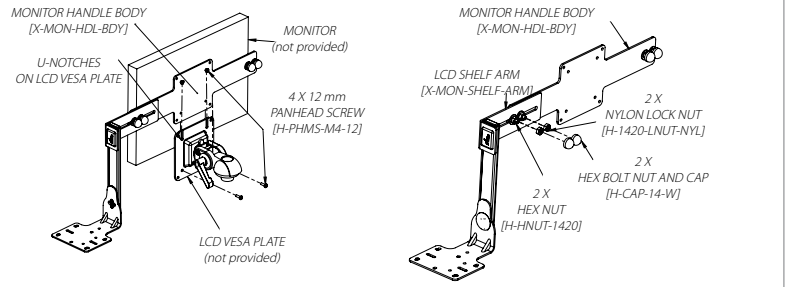

Troubleshooting Guide

| Symptom | Possible Cause | Solution |
|---|---|---|
| Scanner base appears tilted/not centered. | Loose mounting configuration or device has shifted. | Re-center mounting brackets and refer to instructions (Pre-installation and Installation to Device) |
| Mounting bracket is shifting. | Improper installation to mounting platform. | Ensure device is secured to rail or mounting platform. Refer to instructions (Installation to Mounting Platform). |

Maintenance

It is recommended that once every one (1) month, all locks, bolts, and screws are visually inspected for signs of product wear and tear or damage. Check the product for looseness in the mount or orientation, and ensure the adapter is secured to the rail or wall channel system.

Warranty

During the term of warranty: Within the first twelve (12) months from the date of shipment, Amico Accessories will repair or replace any part which is proven to be defective at no cost. After the twelve (12) month period, Amico Accessories will send the parts to the customer free of charge, however shipping and installation will be borne by the customer.

The warranty is valid only when the product has been properly installed according to Amico Accessories specifications, used in a normal manner, and serviced according to factory recommendations. It does not cover failures due to damage which occur in shipments or failures which resulted from accidents, misuse, abuse, neglect, mishandling, alteration, misapplication or damage that may be attributable to Force Majeure.

AMICO ACCESSORIES DOES NOT HONOR VERBAL STATEMENTS CONCERNING THE WARRANTY.

The distributor and/or dealer are not sanctioned to create verbal warranties about the product described in this agreement. Any statements will not be honored or be made part of the agreement of sale. This document is the final complete and exclusive terms of the agreement.

THIS WARRANTY IS INCLUSIVE AND REPLACES ALL OTHER WARRANTIES.

Amico Accessories shall not, under any circumstances be liable for incidental or consequential damages including, but not limited to, profit, loss of sales or injuries to person(s) or property.

Correction of non-compliance as noted above will result in completion of all liabilities of Amico Accessories whether based on agreement, neglect or changed materials, designs or specifications without notice.

All claims for warranty must first be approved by Amico Accessories Customer Service Department: (info@amico-accessories.com or 1-877-264-2697). A valid Return Goods Authorization number must be obtained from Amico Accessories prior to commencement of any warranty claim.