

Regulator

AM 700



General Specifications:

The Amico AM 700 Series High Flow Regulator shall be for a line supply, of a single stage and extra heavy duty type.

Application & Uses

High capacity gas service
 Designed for gas distribution systems
 Available with 1/2" NPT(F)
 Inlet pressure up to 350 PSIG

Design Construction

Forged brass body and housing cap
 2-1/2" brass gauge
 Stem type seat mechanism
 3-1/4" diaphragm
 Delrin cap bushing for smooth adjustments

Performance

Maximum Inlet - 350 PSIG
 Delivery Range - 10 to 200 PSIG
 Flow - see flow chart

Specifications & Materials

Dimensions - 7-1/4"W x 7"H x 5-1/8"D
 (18.6 cm x 17.9 cm x 13.1 cm)

Weight - 5 lbs. 2 oz. (2.5 kg)
 Body - Forged Brass
 Diaphragm - Neoprene
 Housing Cap - Forged Brass

Flow Chart AM 700

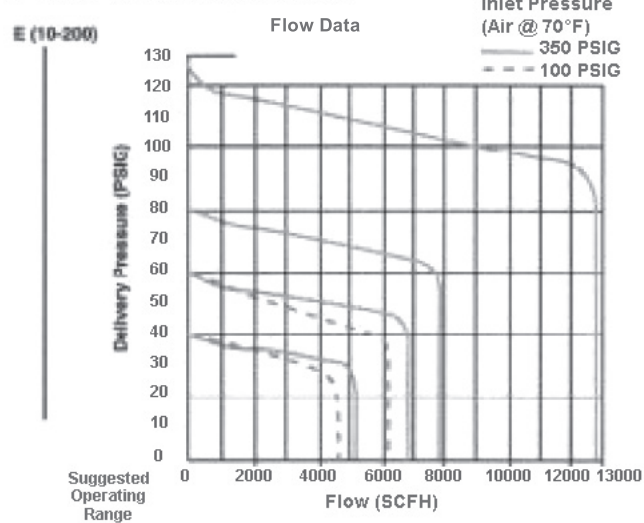

Technical Specifications

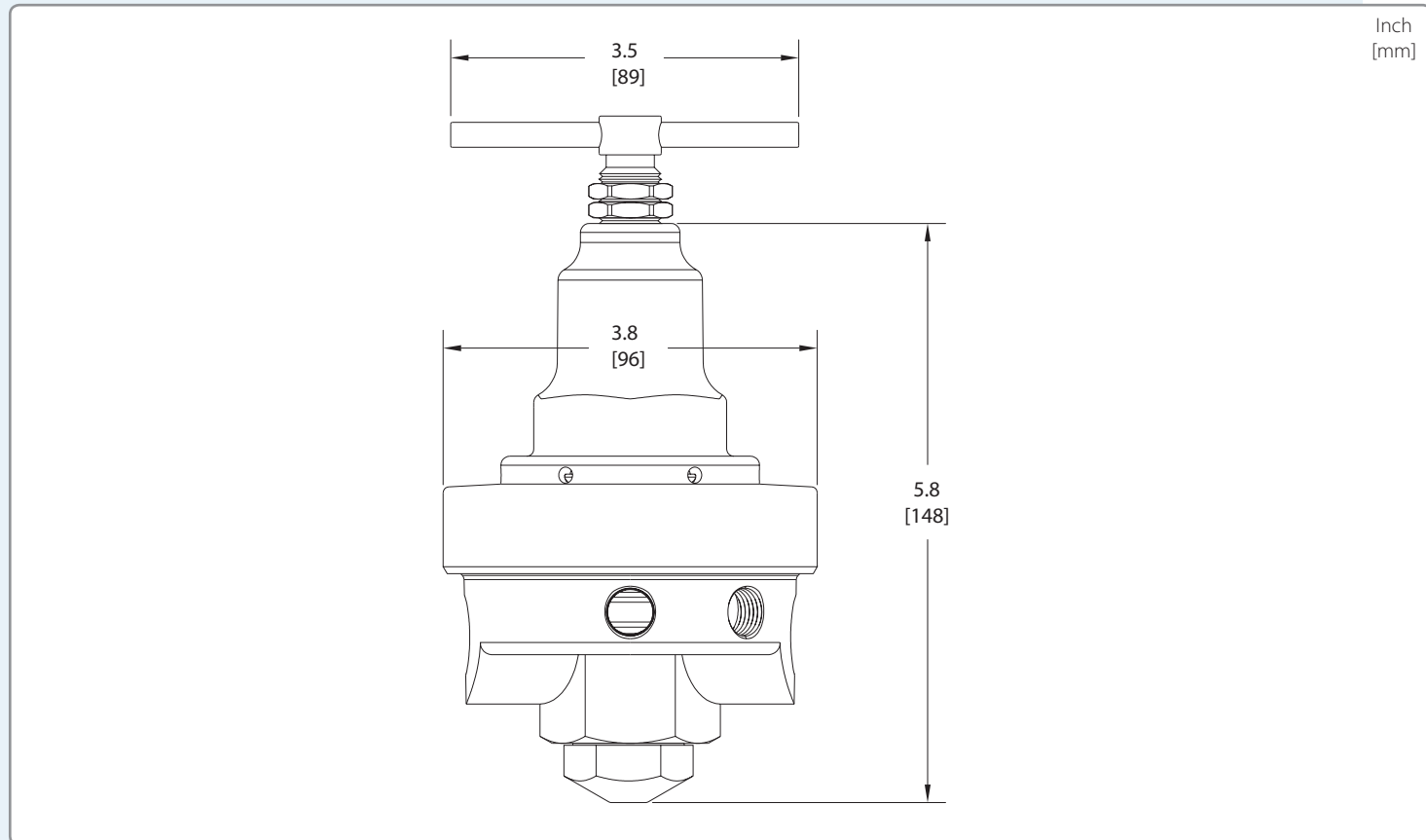

Model Numbers

AM 700 Series High Flow Regulator

AM 700 Series High Flow Regulator with 200psi Gauge

M2-X-MAN-42E

M2-X-MAN-42E-G