

Operating & Maintenance Manual

Automatic Medical Gas Manifold Analog Dome Loaded Regulator NFPA v1.4



Contents

User Responsibility	4
Introduction	5
Features	5
Description of the Manifold	6
Shipment Details	6
The Manifold Enclosure	6
Header Bar Wall Support Bracket	6
Manifold Display Board	6
Description of Parts	7-10
Main Line Source Valve	7
Bank Regulator	7
Pressure Transducers	7
Check Valve	7
Line Regulator Ball Valve	8
Dual Line Regulator	8
Pressure Relief Valve	8
Pilot Regulator	8
Solenoid Valve	8
Front Panel Indicators	9
Power Supply	9
Control Board	9
Gas Service Identification	10
Header Bar Connections	10
Operating Alarm System	10
Display Functions	11
Installation	12
Wall Mounting Instructions	13-14
Cylinder Bank Installation Instructions	15
Testing for Leakage	16-17
Initial Power-Up	18-19
Gas Flow Through the Manifold	20
Manifold Switchover	21
Performance Verification	22-23

Bank Regulator Pressure Adjustment	24
Bank Regulator Replacement	25
Line Regulator Pressure Adjustment	26
Line Regulator Replacement	26
Control Board Replacement	27
Cylinder Changing Procedures	28
Ordering Information	29-30
Control Cabinet Part List	29-30
Appendix A: Manifold Internal Layout	31
Appendix B: Piping Schematic Diagram	32
Appendix C: Wiring Schematic Heater Units	33
Appendix D: Electrical Wiring Diagram	34
Appendix E: Control Cabinet Wiring Diagram	35
Appendix F: Staggered Header Bar	36
Appendix G: Straight Header Bar Setup	37
Appendix H: Optional Header Bar Setup	38
Appendix I: Standard Manifold Flow Rates	39

User Responsibility

The information contained in this Operating and Maintenance Manual pertains only to the Amico Automatic Gas Manifold. This product will perform in conformity with the descriptions contained in this manual when assembled, operated, maintained and serviced in accordance with the installation instructions provided.

The manifold **MUST** be checked periodically. Parts that are broken, missing, worn, distorted or contaminated must be replaced immediately. Should such repair or replacement become necessary, please contact Amico Corporation or their distributors.

For installing CO₂ and N₂O manifolds outdoors, please refer to NFPA 99C:

"Central supply systems for nitrous oxide and carbon dioxide shall be prevented from reaching temperatures lower than the recommendations of the central supply system's manufacturer, but shall never be lower than -7°C (20°F) or greater than 54°C (130°F)."

All manifolds should not be repaired or altered without prior written approval by Amico Corporation or its distributors. Failure to comply will void all warranty on the manifold.

Statements in this manual preceded by the words **WARNING**, **CAUTION**, **DANGER** and **NOTE** are of special significance. Please read these sections carefully.



WARNING: denotes steps which can prevent injury.



CAUTION: denotes steps which can prevent damage to equipment.



DANGER: denotes steps which can prevent electrical shock to equipment or prevent serious injury and/or death.

Introduction

The Amico Automatic Gas Manifold is a one of a kind design that provides a reliable, uninterrupted supply of gas to a hospital or other medical facility. The manifold utilizes multiple high-pressure cylinders divided into two equal banks. One bank is designated as a "Primary" source of gas while the other bank stands in reserve as a "Secondary" source.

A display of LED's on the front of the manifold indicates the status of the gas supply. Each bank has a green "In Use", yellow "Ready" and red "Empty" LED. When the primary bank of cylinders is depleted, the manifold will automatically switch to the secondary bank of cylinders without interruption of gas flow to the facility. The red LED will illuminate when a bank is depleted and two normally closed dry contacts for the Reserve In-Use Alarm will open. One or both sets of contacts may be wired to an external alarm, remote buzzer and/or a building management system.

When replacement cylinders are attached to the depleted bank, the red LED goes out and the yellow LED illuminates indicating that the bank has been automatically designated as the secondary supply. No other user interaction is required. Both sets of dry contacts close to cancel any external alarm condition.

The power supply is connected to the top right hand corner of the manifold. Connections from the manifold to the Amico Master Alarm must be made from terminals marked C/Signal to the appropriate terminals (Reserve In Use) on the Master Alarm or a remote buzzer.

The enclosure for the manifold is NEMA-1 (general purpose applications only) and it is not recommended to be mounted outdoors.

The manifold has a removable front cabinet. The pre-assembled circuit board is mounted directly to the back plate of the manifold. This design will reduce installation time and eliminate the risk of improper installation, since each of the components of the manifold are connected and tested at the factory.

The Amico Automatic Gas Manifold is designed in accordance with the National Fire Protection Association (NFPA 99).

FEATURES INCLUDE:

- Input power to the manifold is 110-240 VAC, 50-60Hz
- Incorporates six LED's and the digital display is readable even in the poorest of lighting conditions
- Dual line pressure regulators
- Single vent access from line and operating relief valve
- Wall mounting bracket attached to manifold for easy installation
- Manifold complies with NFPA 99

Description of the Manifold

SHIPMENT DETAILS

The Manifold system may be shipped in more than one carton, depending on the number of cylinder connections. The main carton contains the following items:

- Manifold control panel (with power supply assembly)
- Wall mounting bracket (attached to manifold control panel)
- 3/4" Source shut-off valve
- Installation, Operation and Service Manual

Additional cartons may contain the appropriate number of header bars and cylinder pigtail assemblies. Standard header bar assemblies are configured so that cylinder inlets are on 11" centers. Cylinders may be placed in a double row "Staggered" or single row "Straight" configuration. Cylinder inlets closest to the manifold control panel are intended for cylinders placed directly beneath the manifold control panel. For gases other than oxygen and helium, 36" stainless steel, flexible type pigtails are used. Oxygen and helium pigtails are rigid copper and are pre-bent to the approximate shape for connection to the cylinders. The manifold is designed to be mounted directly to a wall.

THE MANIFOLD ENCLOSURE

The manifold enclosure contains a switch mode power supply that can handle voltage from 110-240 VAC with a built-in fuse and terminal block. The enclosure on this manifold is NEMA-1 (general purpose applications only). This cabinet must not be mounted outdoors.

The manifold also has a latched door that is easy to remove. The pre-assembled circuit board is located at the center of the enclosure with a hinge mounting bracket. This design reduces installation time and eliminates the risk of improper installation, since all the components of the manifold are connected and tested at the factory.

HEADER BAR WALL SUPPORT BRACKET

The manifold can support, at maximum, a 5x5 staggered header bar. While the straight header bar contains a wall support bracket on every second pipe in between each cylinder, a standard staggered header bar has a wall support bracket in place after every 5 cylinders, unless additional support is requested.

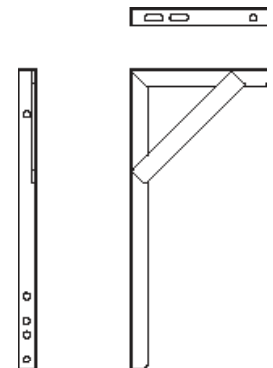

MANIFOLD DISPLAY BOARD

The LED's on the front of the manifold indicate the status of the gas supply. The primary bank will indicate "In Use", with the green LED turned on, and the reserve/secondary indicating "Ready", with the yellow LED turned on, or "Empty", with the red LED turned on depending on the status of the gas supply. When the primary bank of cylinders is depleted, the manifold will automatically switch to the secondary bank of cylinders without interruption of gas flow to the facility. The red LED will illuminate when a bank is depleted and two normally closed dry contacts will open. One or both sets of contacts may be wired to an external alarm, remote buzzer and/or a building management system.

Description of Parts

When replacement cylinders are attached to the depleted bank, the red LED goes out and the yellow LED illuminates indicating that the bank has been automatically designated as the secondary supply. No other user interaction is required. Both sets of dry contacts close to cancel any external alarm condition.

MAIN LINE SOURCE VALVE

A 3/4" isolation valve with a locking handle, supplied with the manifold, should be installed on top of the manifold connecting to the main supply line.

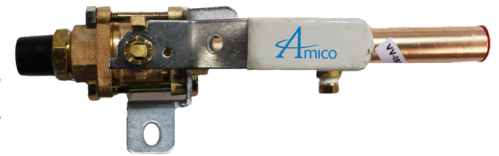

BANK REGULATOR

A dome loaded, single stage, diaphragm type regulator is used to reduce the pressure of incoming cylinder contents to a lower intermediate pressure. A bank regulator (one for each bank of cylinders) has an internal adjusting spring used to set a "base" pressure of approximately 100 psi (200 psi on Nitrogen manifolds). The "dome" (i.e. bonnet or bell) of the regulator is a pressure tight chamber. When pressure is applied to the dome, the amount of force applied is added to the force of the adjusting spring. For example, when 55 psi of pressure is applied to the dome, then the 100 psi base pressure setting is raised to approximately 155 psi.



PRESSURE TRANSDUCERS

The pressure transducer senses the bank pressure and transfers information to the display board to indicate the "In Use", "Reserve" and "Empty" modes. There are two transducers in the manifold cabinet, one for the left bank cylinder and one for the right bank cylinder.



CHECK VALVE

The check valve is located upstream of each bank regulator to prevent back flow while servicing a bank regulator.

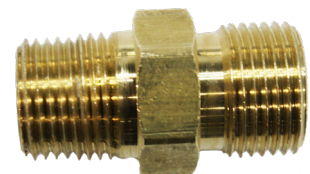

Description of Parts

LINE REGULATOR BALL VALVE

Quarter-turn ball valves are located upstream and downstream of each line regulator. These valves allow for removal and servicing of one line regulator while the other is in use.

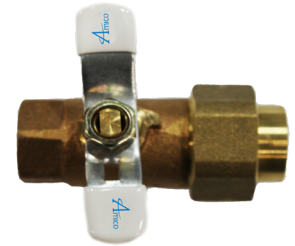

DUAL LINE REGULATOR

On every Amico Automatic Gas Manifold, the line regulator is capable of maintaining a constant dynamic delivery of pressure at the maximum designated flow rate of the system. For Oxygen, Nitrous Oxide, Medical Air and Carbon Dioxide service, the line regulators are factory preset at 55 psi and for Nitrogen at 170 psi.



PRESSURE RELIEF VALVE

Pressure relief valves are installed downstream of all pressure regulators and are set at no more than 50% above the setting of the pressure regulator. Relief valves are capable of fully relieving the pressure at the set point. All pressure relief valves in the manifold have piping connections to allow for connection of a vent line to the outside of the facility.



PILOT REGULATOR

A single stage, diaphragm type, relieving regulator used to limit the amount of pressure provided to the domes of the bank regulator. It is used only on Nitrogen manifolds and manifolds with 100 psi delivery pressure.



SOLENOID VALVE

A 12 VDC solenoid assembly is used to direct dome bias pressure to one of the bank regulators. As dome bias pressure is directed to one of the bank regulators, dome pressure of the other bank regulator is vented through an exhaust in the solenoid valve.

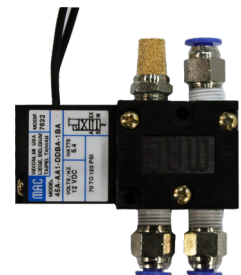

Description of Parts

FRONT PANEL INDICATORS

Six front panel indicators monitor the status of the manifold.

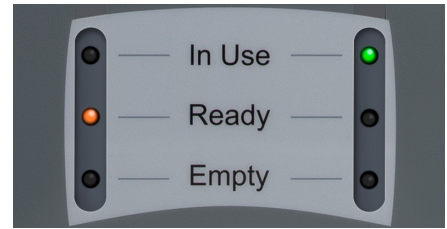

POWER SUPPLY

The power supply is 110-240 VAC, 50-60 hz. It is mounted on the top right hand side of the manifold and is provided with a 1 amp fuse.

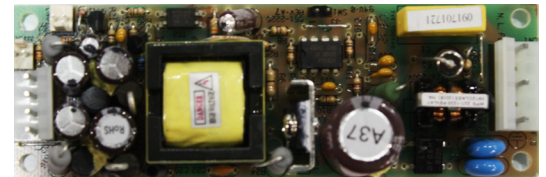

CONTROL BOARD

The control board is an electronic circuit board that controls the bank switchover. It monitors the pressure with the help of the bank transducers and controls the solenoid valve in order to initiate the bank switch or changeover. The control board illuminates the appropriate front panel indicators and also provides dry contacts for the activation of a remote buzzer or external master alarm. Power to the control board is provided by the external power supply.

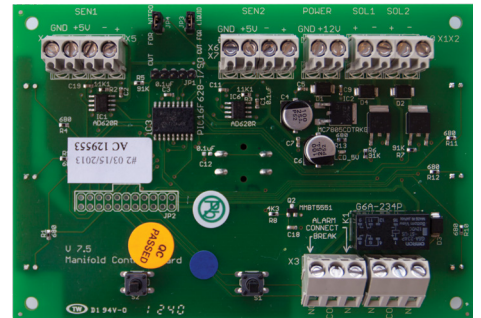

DANGER: Electrical shock hazard. Ensure that the main power source is turned off during the connection of the power supply.

Description of Parts

GAS SERVICE IDENTIFICATION

Amico manifolds are clearly labeled for the intended gas use, with the appropriate gas identified with a label that is attached on the cabinet door. There are two pipes extending from the top of the cabinet: one is for the main line pressure and the other is for the vent of the pressure relief valves, also labeled accordingly.

HEADER BAR CONNECTIONS

The gas-specific header bar should be attached to the Inlet block on either side of the manifold. The Inlet block is provided with a sintered bronze filter and a "C" clip to secure it. The header should contain the proper gas connections and all cylinder bar connections. The pigtail (hose) assemblies should comply with CGA standard B96, "Compressed Gas Cylinder Valve Outlet and Inlet Connections."

OPERATING ALARM SYSTEMS

The manifold control cabinet contains the required circuitry to send a dry contact signal to the alarm unit when a bank is empty and changeover occurs. The normally closed internal circuitry is designed to alarm when there is an open circuit. The depletion of a bank triggers a relay which renders the alarm circuit open and initiates the alarm signal.

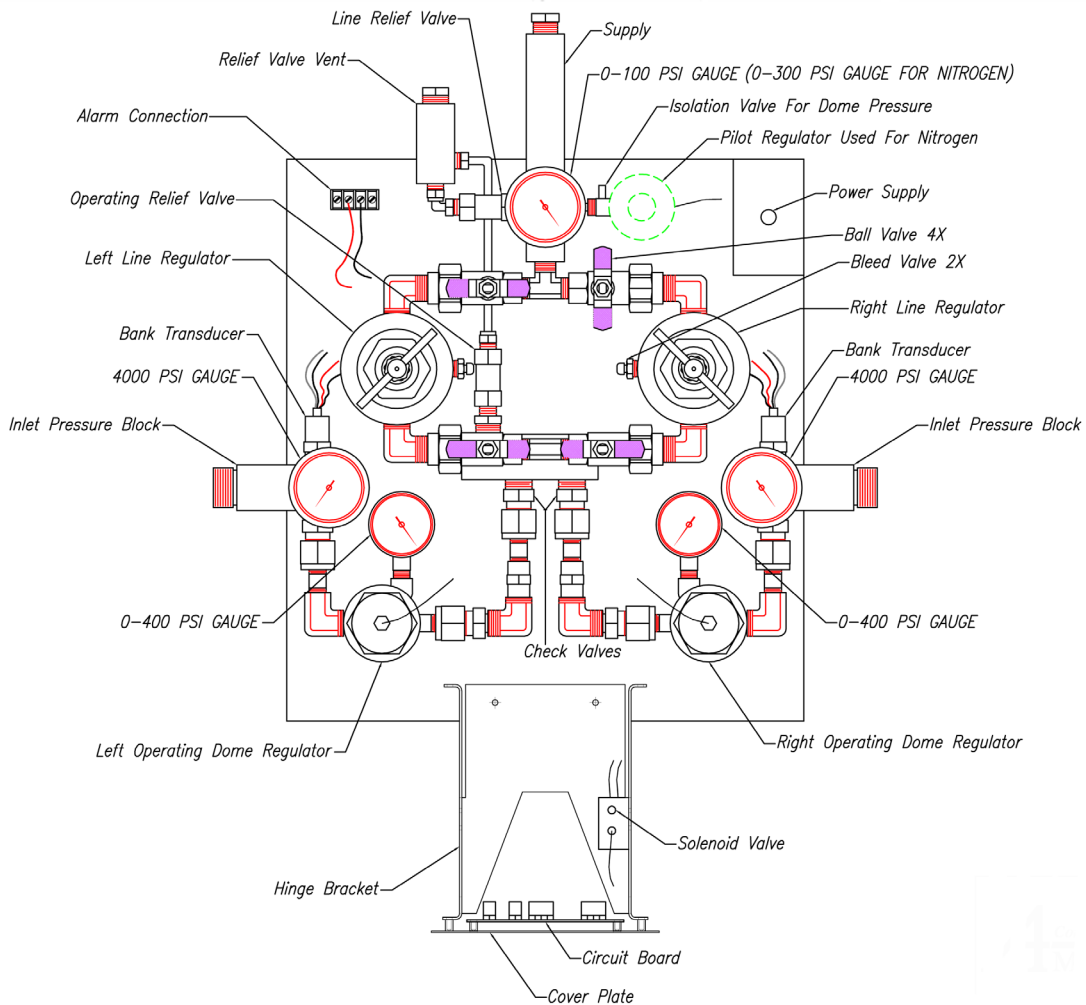

Display Functions

1. Introduce power to the control cabinet.
2. Follow the Cylinder Changing procedure on the side of the cabinet to ensure that all cylinders and fittings are secure and properly connected to the header bar.
3. Check the indicator LED for proper functioning.
4. Only one green LED, on the side which had its operating regulator set first, should be lit and the other side should have a lit yellow LED.
5. Close the cylinder valve on the primary bank and watch the indicator LED to ensure proper functioning. The primary bank pressure should fall, while the secondary and line pressures stay constant.
6. When the primary pressure falls to approximately 120 psi for all gases (or 220 psi for Nitrogen) the bank switchover occurs. The line pressure will remain constant with the LED display indicating the bank “In Use”.
7. With the Amico Automatic Gas Manifold wired up to the Amico Master Alarm, the changeover from “Primary” to “Secondary” supply will cause an audible alarm buzzer and the appropriate indicator LED on the Master Alarm will illuminate. This can also be achieved by using the switchover test button located on the back of the control board.

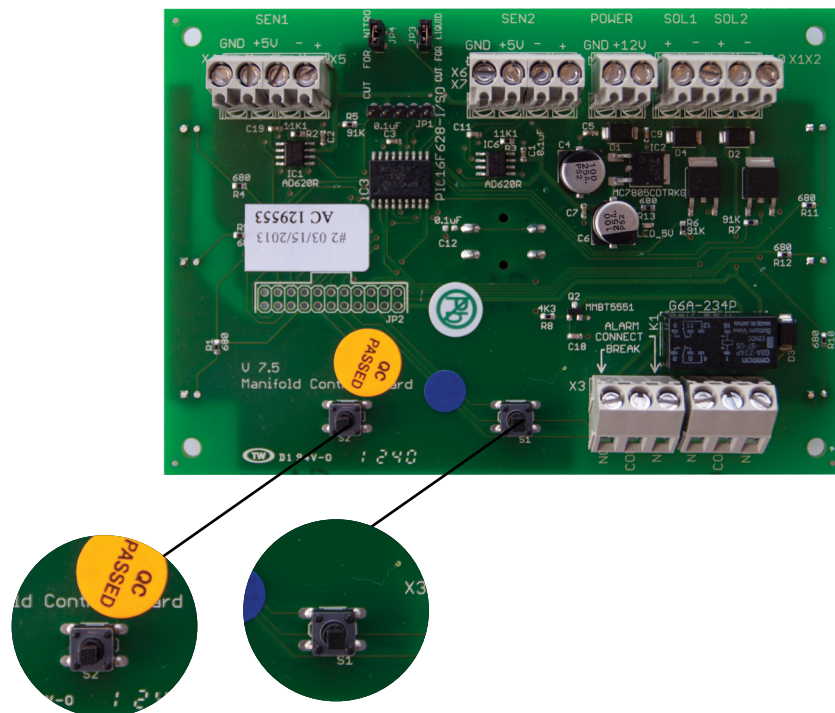

Installation

PRECAUTIONS

- Tampering with gas specific connections shall be prohibited. Do not alter, remove or modify gas specific connections.
- Keep all manifold parts, tools and work surfaces free of oil, grease and dirt. These and other flammable materials may ignite when exposed to high pressure oxygen or nitrous oxide.
- Do not use chemicals, lubricants or sealants unless specified in these instructions.
- Before connecting cylinder to manifold, momentarily open and close cylinder valve to blow out dirt and debris.
- After connecting cylinder to manifold, open cylinder valve S-L-O-W-L-Y to allow heat of compression to dissipate.
- Do not use flame or "sniff" tests for leaks.
- Do not apply heat to any part of the manifold system.
- Always secure high-pressure cylinders with racks, straps or chains. Unrestrained cylinders may fall over and damage or break off cylinder valve.
- Do not repeatedly bend, sharply bend or twist copper pigtailed as damage to tubing may occur.
- After the manifold wall bracket has been mounted, one person alone should not attempt to lift and hang the manifold cabinet.
- Do not put the manifold into operation until verified by a qualified person as per NFPA 99 or other local standards.

Wall Mounting Instructions

1. Remove manifold control panel from the shipping carton. If the manifold will be placed on a flat surface in the upright position, do not remove the foam packaging material or the manifold may tip over. Only remove the foam packaging material when ready to hang the manifold on the mounting bracket (in step 4).
2. Using the back support bracket as a template, place on the flat wall and align the top of the bracket with the level horizontal line. The vertical center line of the bracket will be the vertical center line of the installed manifold. The support bracket should be mounted 61-1/2" [1,562.1 mm] from the finished floor to the bottom hole of the bracket as shown in **Figure 1**.
3. Mark locations of mounting holes. Remove the bracket and drill mounting holes. Attach the bracket to the wall with appropriate anchors (supplied by others). 3/8" [9.525 mm] diameter anchors are recommended.

Figure 1

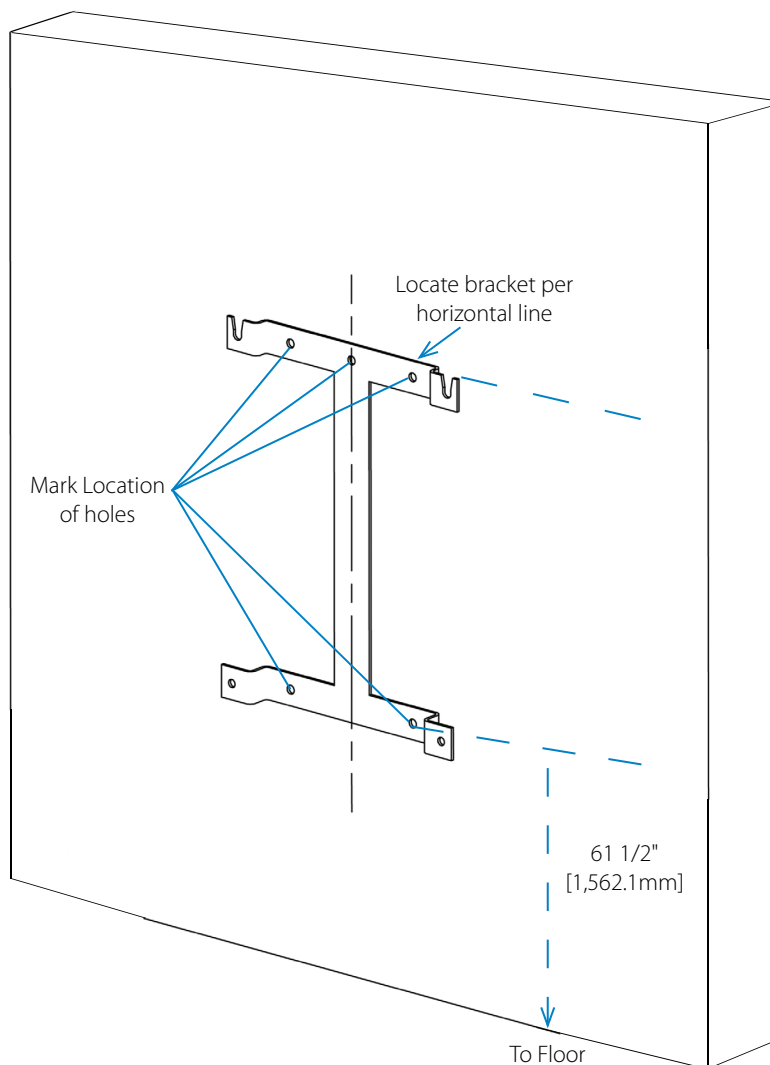

Wall Mounting Instructions

4. Hang the manifold control panel on the mounting bracket. The top two control panel mounting bolts will slide into slots of the bracket. The bottom of the manifold control panel should be angled away from the bracket until the top two bolts have been inserted as shown in **Figure 2**.

NOTE:

A bracket mounting height of 61-1/2" [1,562.1 mm] from the finished floor to the bottom hole on the support bracket allows for adequate clearance beneath the manifold when utilizing standard "H" size or slightly taller cylinders.

5. The bottom of the control panel can then be positioned so that the holes at the bottom of the panel align with the holes in the hanging bracket. Use 3/8" [9.525 mm] bolts to secure the cabinet to the bracket as shown in **Figure 3**.

Figure 2

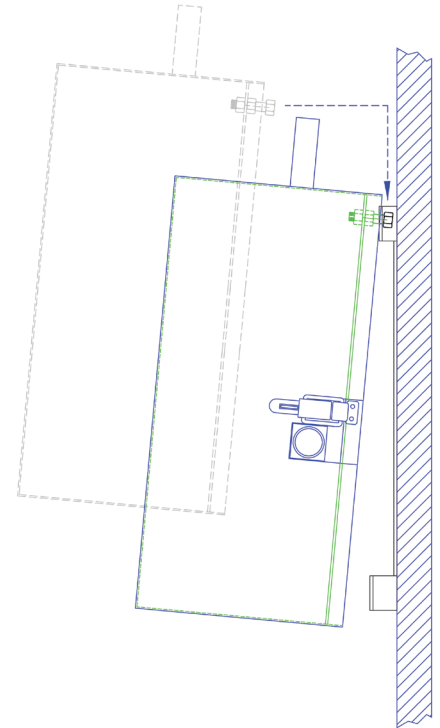
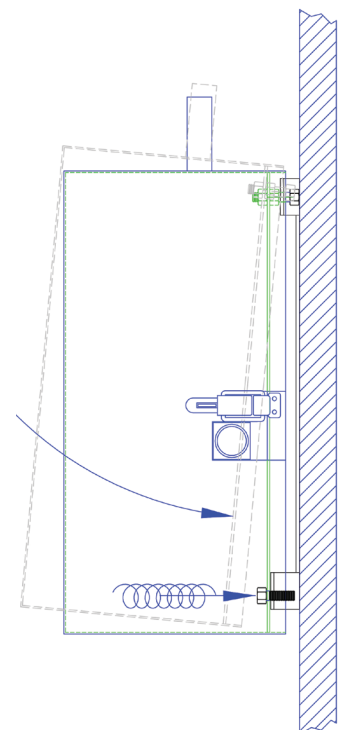

Figure 3



WARNING: Do not attempt to lift manifold alone. Two people are recommended in order to hang the manifold onto the wall mounting bracket.



CAUTION: Do not use thread sealant on header or pigtail connections.



CAUTION: Each header segment must be supported by a header bracket before additional header segments are added.

Cylinder Bank Installation Instructions



CAUTION: This section contains important information necessary for proper installation of the cylinder banks. Read it carefully before installing cylinder banks.

- Position the wall brackets, if required, to support the header bars and bolt in place.
- Connect the two high pressure inlet valve/header bar assemblies to the inlet blocks on either side of the cabinet.
- Secure the header bar assembly by tightening the union nuts onto the inlet blocks. The manifold can support a maximum 5x5 staggered header bar. The straight header bar contains a wall support bracket on every second pipe in between each cylinder, for the staggered orientation a support bracket is installed after every 4-5 cylinders, unless additional support is required.
- Remove the plug and chain assembly on each of the outlet connections on the cylinder extension bar. Attach the cylinder pigtails to the header bar connection, while ensuring the check valves are operating in the proper direction.



WARNING: To avoid contamination with particles or other potentially hazardous materials, keep pigtails in plastic wrapping until such time as connection to the gas cylinder is planned.

- When the medical gas piping system has been tested in accordance with NFPA 99, the manifold can then be connected to it.
- The outlet pipes leading from the Amico control cabinet should be connected to their respective pipeline system connections. The connection to the relief valves should be made with a union (supplied by others) to facilitate change, if required.
- An appropriate sealing compound that is suitable for the gas being transmitted shall be used for threaded connections.



WARNING: If downstream joints near the cabinet outlet are to be silver brazed, special attention must be given not to overheat the copper tubing, since this may alter the sealing compound used in the threaded joints leading from the control cabinet.

Testing for Leakage

The following instructions apply for performing a leak test on the joints made during assembly and connection of the Amico manifold.

The connections inside the Amico control cabinet have been inspected at the manufacturing plant and **DO NOT** require leak testing. In order to determine whether any leaks exist between cylinder header bar sections or at the pipeline connections, the systems must be pressurized using either oil-free dry air or oil-free dry nitrogen.

In the case of Medical Oxygen, Nitrous Oxide, or Carbon Dioxide Amico Manifolds, the actual service gases **ARE NOT** suitable for leak testing due to their inherent dangerous properties. Leak testing must be performed using either oil-free dry air or oil-free dry nitrogen. In the case of either Medical Air or a Nitrogen Amico manifold, the actual service gas may be used to perform the leak tests as follows:

1. Connect a cylinder of the manifold service gas to each side of the header bar using the proper cylinder connection hose assemblies (pigtailed) supplied.
2. Make sure all other outlets are capped with the plug and chain assemblies supplied.
3. Make sure that the high pressure inlet valves of each bank are fully **OPEN**.
4. **S-L-O-W-L-Y** open the two cylinder valves on each side of the cabinet, one at a time, to pressurize the header bar and pipeline.
5. All outlets from the pipeline, downstream of the manifold, should be closed and thus there should be no flow from the manifold.
6. Check for leaks at all cylinder extension joints and at the joints where the pipes are connected to the pipeline, using a commercial leak detector which is compatible with oxygen.
7. If any leaks are found, the system must be depressurized by bleeding through a convenient pipeline outlet and the faulty connections must be repaired.
8. The header bar connections may be tightened one more turn to maintain the horizontal location of the cylinder adapters or a further application of an oxygen service threaded sealant may be required.
9. If the brazed pipeline connections leak they must be removed, cleaned and then re-brazed following the proper technique. All repaired joints must be pressure tested as above.

Testing for Leakage

PRECAUTIONS

The Amico Automatic Gas Manifolds are designed in accordance with the current revision of NFPA 99.

There are three categories of Amico manifolds depending upon the delivery pressure. The following gas types are available for each delivery pressure:

55 psi Delivery Pressure

- Oxygen, Nitrous Oxide, Medical Air, Carbon Dioxide, Helium, Argon

100 psi Delivery Pressure

- Oxygen, Medical Air, Carbon Dioxide

170 psi Delivery Pressure

- Nitrogen, Instrument Air

Delivery (Line) Pressure - (see above)

	55 psi	100 psi	170 psi
Intermediate Pressure - Ready Bank	100 psi	200 psi	200 psi
Dome Bias Pressure	55 psi**	50 psi	50 psi
Intermediate Pressure - In-Use Bank	150 ± 10 psi*	250 ± 10 psi	250 ± 10 psi
Intermediate Relief Valve	350 psi	350 psi	350 psi
Line Regulator Relief Valve	75 psi	150 psi	225 psi
Maximum Inlet Pressure	3000 psi	3000 psi	3000 psi

* The intermediate pressure valve of the "In Use" bank is dependent upon the dome bias pressure. Variations from the 55 psi delivery pressure will affect the intermediate pressure reading.

** Same as delivery pressure.

Initial Power-Up

1. Release the two latches on either side of the manifold control panel and remove the cover.
2. Verify the following:
 - Both master valves located on both header bars are turned fully counter clockwise (open)
 - All four line regulator isolation valves are open (handles horizontal)
 - Power supply has been connected
 - Both red "Empty" indicators on the front of the manifold are illuminated
 - If connected to a master alarm panel, "Secondary Supply" alarm is activated
3. Close 3/4" source shut-off valve.
4. Slowly open one cylinder on the right side of the manifold.
5. Verify the following:
 - Right bank red "Empty" LED goes out
 - Right bank green "In Use" LED illuminates
 - Right bank cylinder contents gauge reads cylinder pressure
6. Slowly open one cylinder on the left side of the manifold.
7. Verify the following:
 - Left bank red "Empty" LED goes out
 - Left bank yellow "Ready" LED illuminates
 - Left bank cylinder contents gauge reads cylinder pressure
 - If connected to a master alarm panel, "Secondary Supply" alarm is not activated
8. Close right bank cylinder. Slightly depress bleed valve located on the side of the regulator. Verify the following:
 - Right bank cylinder contents gauge drops slowly
 - As the right cylinder contents gauge is nearly depleted, the manifold changes over to the left bank
 - After changeover, the right bank green "In Use" LED goes out and the red "Empty" LED illuminates
 - After changeover, the left bank yellow "Ready" LED goes out and the green "In Use" LED illuminates
9. Verify the line pressure gauge reading is acceptable.
10. Slowly open one cylinder on the right side of the manifold.

Initial Power-Up

11. Verify the following:

- Right bank red "Empty" LED goes out
- Right bank yellow "Ready" LED illuminates
- Right bank cylinder contents gauge reads cylinder pressure

12. Close the left bank cylinder. Depress the valve located on the side of the line regulator. Verify the following:

- Left bank cylinder contents gauge drops slowly
- As left cylinder contents gauge is nearly depleted, the manifold changes over to the right bank
- After changeover, the left bank green "In Use" LED goes out and red "Empty" LED illuminates
- After changeover, the right bank yellow "Ready" LED goes out and green "In Use" LED illuminates

13. Slowly open one cylinder on the left side of the manifold.

14. Verify the following:

- Left bank red "Empty" LED goes out
- Left bank yellow "Ready" LED illuminates
- Left bank cylinder contents gauge reads cylinder pressure
- If connected to a master alarm panel, "Secondary Supply" alarm is not activated

15. Close the left and right side cylinders.

16. Record the pressure readings of the left and right bank cylinder contents gauges.

17. Wait 15 minutes.

18. Compare current readings of the left and right bank cylinder contents gauges to those recorded in step 16. If there is a noticeable pressure change on either gauge, perform leak testing described in Leak Testing on page 17.

19. Reinstall manifold control panel cover.

20. Slowly open all cylinders for both banks of the manifold.

21. Open 3/4" source shut-off valve.

Gas Flow Through the Manifold

High pressure gas is provided to the left and right manifold bank inlets via cylinders, pigtailed and header assemblies. Flow of high pressure gas through the left and right side of the manifold is identical, each passing through a master valve located on the header and then directly to a bank regulator.

Bank regulators reduce incoming cylinder pressures to an intermediate pressure. Bank regulators are referred to as a "dome loaded" type of regulator. These regulators have an internal adjusting spring manually set at a specific pressure similar to other diaphragm type pressure regulators. In addition to an internal adjusting spring, bias pressure may be applied to the dome of the regulator (on the adjusting spring side of diaphragm) thus boosting pressure above what is manually set by the adjusting spring. This output pressure boost will be approximately equal to the amount of bias pressure.

For example, if a bank regulator is manually adjusted to 100 psi via the internal adjusting spring, and a dome bias pressure of 55 psi is applied, the output pressure will increase to approximately 155 psi (100 + 55). When the bias pressure is removed, the output pressure setting will return to 100 psi.

Outputs of both the left and right bank regulators pass through check valves and connect together upstream of the dual line regulator assembly. An intermediate relief valve protects components between the bank and line regulators in the event of a bank regulator seat failure.

The dual line regulator assembly consists of two line regulators plumbed in parallel with upstream and downstream isolation 1/4" turn ball valves. Output of both the line regulators tee together and exit at the manifold's main outlet. A line relief valve along with a line pressure gauge is connected to the manifold's main outlet.

Outlet pressure is then routed to a dome regulator reducing pressure to 55 psi at the solenoid switch. The solenoid switches 55 psi (dome bias pressure) to one of the bank regulators. When one bank regulator is supplied bias pressure, the other bank's dome regulators are vented to the atmosphere. An electronic circuit board controls the solenoid valve based upon the input received from the right and left pressure transducer. The solenoid valve directs bias pressure to the bank designated as primary.

Manifolds designed for 55 psi nominal output pressure do not incorporate a Pilot regulator. Full line pressure (55 psi) is routed directly to the solenoid valve which is used as dome bias pressure.

Manifold Switchover

After electrical power has been applied to the manifold, the side pressurized first is designated primary or "In Use" bank. In order to simplify the following explanation, we will arbitrarily select the right side of the manifold as primary bank. The green "In Use" LED on the right side will be illuminated and the yellow "Ready" LED on the left (secondary) bank will be illuminated.

The solenoid valve directs dome bias pressure to the bank regulator on the right side. If we use a 55 psi oxygen manifold as an example, the output of the right bank pressure regulator is approximately 155 psi (100 psi base pressure + 55 psi bias pressure). The output of the left bank regulator is approximately 100 psi (base pressure only, no bias pressure). Since the bank regulator on right side has the highest pressure, all flow is supplied by the right bank of cylinders.

As the cylinder pressure on the right side depletes, the pressure transducer on that side signals to the circuit board to switch the solenoid valve. The solenoid valve then vents the dome bias pressure from the right bank regulator and directs the bias pressure to the left bank regulator. The green LED "In Use" on the right side goes out and the red "Empty" LED illuminates, indicating a "Reserve In-Use" alarm with the yellow LED on left going off and the green LED being illuminated.

When cylinders on the right side are replaced and pressure is restored, the right pressure transducer sends a signal to the circuit board, which in turn cancels the remote switchover alarm and the red "Empty" LED turns off and the yellow "Ready" LED gets illuminated.

Since the left bank regulator has the dome bias pressure applied, its output pressure is boosted to approximately 155 psi. The right bank regulator has no dome bias pressure and its output pressure is controlled only by base pressure (100 psi). All flow is supplied by the left bank of cylinders until the pressure drops to approximately 120 psi, the pressure transducer sends a signal to the circuit board, causing a switchover to the right side in same fashion as previously described.

NOTE:

In the event of a power fluctuation or failure, a switchover alarm will be activated on the master alarm.

- For the bank "In Use" the solenoid valve will continue to direct dome bias pressure until the bank depletes and the "Reserve" bank takes over
- The solenoid valve will not prevent the flow of gas from being supplied no matter which side is "In Use" and until the system is fully depleted of gas

Performance Verification

Use the following test steps to verify the manifold's functional performance:

1. Remove manifold cover.
2. Before beginning the test, verify the following:
 - If the manifold is not in use, close the 3/4" source shut-off valve
 - Verify that the two right side line regulator isolation valves are open and the two left side line regulator isolation valves are closed
3. As a starting point for this procedure, set the manifold to have the right bank as "In Use". If the right bank green LED is illuminated, proceed to the next step. If the left bank green LED is illuminated, manually switch the manifold to the right side by pressing the left switch on the control board.
4. Verify that the right bank green LED "In Use" and the left bank yellow "Ready" lights are illuminated.
5. If the manifold is connected to a master alarm panel, verify that the manifold switchover alarm is not activated.
6. If the manifold is equipped with a pilot regulator, verify that its gauge reads 50 psi.
7. Verify the gauge reading for the "In Use" right bank regulator. If the pressure is not correct, refer to the Bank Regulator Pressure Adjustment procedure.
8. Verify the line pressure gauge reading. If the pressure is not correct, refer to the line regulator pressure adjustment procedure. Note the reading for later use.
9. Watch the pressure gauge readings of the right side bank regulator and the line pressure gauge for at least five minutes. Readings may be slightly higher without vent flow but verify the readings do not continue to increase.
10. Close all cylinders on the right side of the manifold. Use the bleed valve on the line regulator to slowly vent off pressure until the right bank high pressure gauge drops. Verify that the manifold switches to the left bank when the right bank high pressure gauge drops below the specified setting of the bank regulator.
11. Verify that only the left bank green "In Use" LED and the right bank red "Empty" LED are illuminated.
12. If the manifold is connected to a master alarm panel, verify that the switchover alarm is activated.
13. Close the right side line regulator ball valves and open the left line regulator ball valves.

Performance Verification

14. Slightly depress the bleed valve on the left line regulator to create a small flow of gas through the manifold.
15. Verify the pressure gauge reading on the bank "In Use" regulator to see if it is set up as per the specified pressure setting. If the pressure is not correct, refer to the Bank Regulator Pressure Adjustment procedure.
16. Verify that the line pressure gauge reading is the same as in step 9. If the pressure is not correct, refer to the Line Regulator Pressure Adjustment procedure.
17. Watch the pressure gauge readings on the left bank regulator and the supply line for at least five minutes to ensure the readings do not continue to increase.
18. Close all cylinders on the left side of the manifold. Depress the bleed valve slightly so that the left bank high pressure gauge drops slowly. Verify that the manifold switches to the right bank when the left bank high pressure gauge drops below the specified setting of the bank regulator.
19. Verify only the right bank green "In Use" LED and the left bank red "Empty" LED are illuminated.
20. Slowly open a cylinder on the left side. Verify that the left bank red "Empty" LED goes out and the left bank yellow "Ready" LED illuminates.
21. Open both of the right side line regulator ball valves.
22. Close the left and right side cylinders.
23. Record the pressure readings of the left and right bank cylinder content gauges.
24. Verify after 15 minutes that the pressure reading on the gauges has remained the same.
25. Slowly open all cylinders on both banks of the manifold.
26. Using the switches on the circuit board, switch the manifold to the bank of cylinders with the least pressure.
27. Reinstall the manifold control panel cover.
28. Open the 3/4" source (line) shut-off valve.

Bank Regulator Pressure Adjustment

This procedure should only be performed if the bank regulator pressures are not within acceptable limits during the Performance Verification procedure or after installation of a new bank pressure regulator.

Base pressure setting is a mechanical adjustment controlled by the regulator's internal adjusting spring and without any dome bias pressure. Recommended settings are listed in the table on page 17 under the heading of Intermediate Pressure - Ready Bank. After the base pressure has been set, the pressure will be increased by the amount of dome bias pressure applied.

1. Shut off all cylinders on both banks of the manifold.
2. Close the main supply source valve.
3. Using the control board switches, cycle the manifold from bank to bank to vent residual dome bias pressure.
4. Remove nylon tube, then, using a 9/16" wrench, remove pipe (quick connect) adaptor from the dome of bank regulator(s) to be adjusted.
5. Depress the bleed valves on both line regulators to relieve all pressure from the manifold.
6. Slowly open one cylinder on the side of the manifold that needs adjustment. For example, if the right bank regulator needs adjustment, open one cylinder on the right side of manifold.
7. Slightly vent off the pressure from the bleed valve to create a small flow of gas through the manifold.
8. Using a 7/32" Allen wrench through the hole of the dome/bell, set the bank regulator to the specified setting: Intermediate Pressure-Ready Bank.
9. Close cylinder valves.
10. If the other bank regulator also needs to be adjusted, repeat steps 6 through 10.
11. Apply Teflon tape, reinstall the pipe (quick connect) adaptor on dome of bank regulator and reinstall the nylon tube.
12. Slowly open all cylinders on both manifold banks.
13. Open main supply source valve.

Bank Regulator Replacement

Should it be necessary to replace the bank regulator, it can be done while the manifold is in service. However, this should only be done by qualified technicians experienced in servicing medical equipment.

1. Remove the two top screws at the base of the display board bracket and tilt back the display board assembly for easy access to the union nuts that secure the bank regulator. (Follow the instructions on the label).
2. Close all cylinders on the side of the manifold where the bank regulator is to be replaced.
3. Ensure that the service bank is the reserve/secondary. If not, cycle the manifold from "In Use" to "Reserve" by using the circuit board control switch to vent residual dome bias pressure.
4. Slowly break the 1-1/8" union(s) allowing gas to slowly vent out from both the inlet and outlet side of the bank regulator.
5. Remove the nylon tube from the regulator dome.
6. Install the new bank regulator. This may require slight adjustment to the fittings on the regulator to align with the secure fittings on the manifold.
7. Tighten the union nut on the inlet and outlet of the new bank regulator.
8. Reinstall the nylon tube.
9. Close the display board assembly and attach the bracket with the two screws.
10. Slowly open the cylinders and set the bank regulator's output pressure as described in Bank Regulator Pressure Adjustment procedure.

Line Regulator Pressure Adjustment

This procedure should be performed if the line regulator pressure is not within acceptable limits during the Performance Verification procedure, or after installation of a new line regulator.

1. With both the bank regulators supplying pressure, open only one ball valve on the inlet and outlet of the line regulator to be adjusted.
2. Slightly open/depress the bleed valve on the side of the regulator to create a small flow of gas through the manifold.
3. Using the handle on the bonnet of the regulator, turn to adjust the pressure to the specified setting mentioned on the cabinet door by observing the line gauge.
4. Repeat steps 1-3 to adjust the other line regulator.
5. After adjusting the pressure to the specified setting open all ball valves and ensure the supply line remains open.

Line Regulator Replacement

If necessary, the line regulator replacement can be performed while the manifold is in service. However, this should only be done by qualified technicians experienced in servicing medical equipment.

1. Close the two ball valves on the inlet and outlet of the line regulator to be replaced.
2. Loosen union nuts on the two closed isolation valves.
3. Vent pressure from the bank which was shut off in step 2 by depressing the bleed valve on the side of the regulator.
4. Ensure the orientation of fittings (direction of gas flow) is the same on the replacement regulator. Install fittings on the new regulator.
5. Inspect the O-ring removed from the ball valve union. If damaged, replace the O-ring.
6. Verify the correct orientation of fittings on the regulator, some slight adjustment may be required to align with the ball valves without causing stress to the fittings.
7. Hand-tighten the two ball valve union nuts and then, with a wrench, lightly tighten to ensure that the fittings are secure. **NOTE:** do not over-tighten unions, as it is an O-ring seal.
8. Open the ball valves and set the line regulator's output pressure as described in the Line Regulator Pressure Adjustment procedure.

Control Board Replacement

If necessary, the control board replacement can be performed while the manifold is in service. However, this should only be done by qualified technicians experienced in servicing medical equipment.

1. Remove the two top screws at the base of the display board bracket and tilt back the display board assembly.
2. Disconnect the power supply.
3. Remove the screws located on the circuit board, detaching it from the front plate. Note the orientation of the old circuit board and remove the wires one at a time and connect each wire to the appropriate terminal on the new board.
4. Install the circuit board and fasten the screws to secure it. Turn the bracket to its original position and then fasten the two screws at the base.
5. Reconnect the power supply to the manifold cabinet.
6. Check the correct operation of the circuit board by simulating a bank switchover a couple of times.

Cylinder Changing Procedures

1. Keep the main bank valve open throughout these procedures.
2. Close the cylinder valves on all empty cylinders.
3. Disconnect the pigtails from the cylinder valve outlets, using an appropriate wrench.
4. Place the protective caps over the cylinder valves of the empty cylinders and move them aside.
5. Remove the protective caps of the full cylinders. Visually inspect the cylinder valves for dust, grease or oil.
6. Using a clean (lint free) cloth, wipe each cylinder valve outlet clean. Do not use your fingers.
7. Standing to one side, "crack" each cylinder valve by briefly opening and closing to blow out any dust. Make sure they are pointing away from you and other personnel.
8. Connect the pigtails to the cylinder valve outlets and tighten the nut with an appropriate wrench.
9. Very S-L-O-W-L-Y open the cylinder valve on the cylinder closest to the control cabinet. Watch the bank pressure display on the front of the cabinet to make sure the pressure rises slowly to the full cylinder pressure reading. Wait one full minute.
10. S-L-O-W-L-Y open the remaining cylinder valves one at a time.



WARNING: High pressure oxygen systems must be handled with **CAUTION**. Spontaneous combustion may occur if oxygen comes into contact with grease or oil. Ensure that hands, gloves, clothing and tools are kept clean and free of oil and grease. Be careful not to introduce dust or other contaminants into the system when changing cylinders. Failure to comply with this procedure may be hazardous.



WARNING: Fire Hazard. **DO NOT** permit smoking or any other source of ignition in the area where the manifold is located or near the relief valve vent outlet. Be certain that all connections are free of dirt, grease and oil. These substances burn with great intensity in air enriched with oxygen or nitrous oxide and some gas mixtures.

Ordering Information

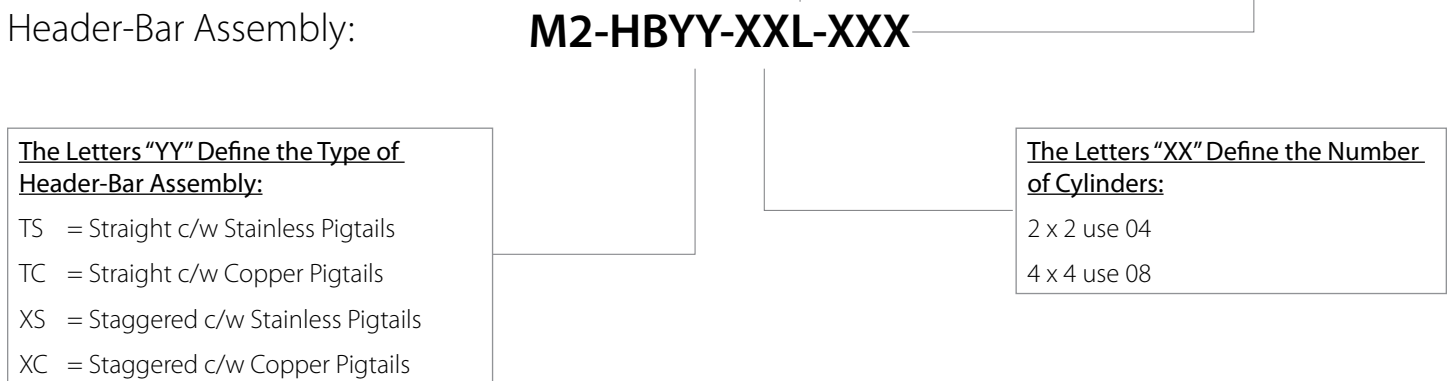
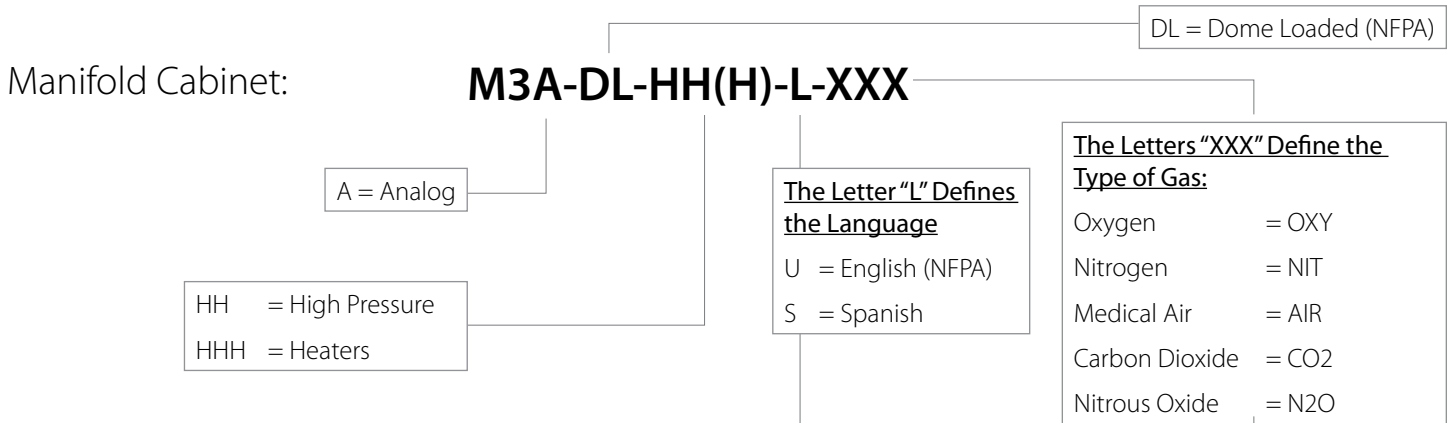

Wall Bracket for Header-Bar Assembly: **M-X-HB-WLBRKIT**

Control Cabinet Parts List

DESCRIPTION	MODEL NUMBER
Pressure sensor for Oxy, N ₂ O, Air, CO ₂ , & Nit	M2-X-MAN-SENS1
Line pressure regulator for Heavy Duty Manifolds (Left)	M2-X-MAN-42E-L
Line pressure regulator for Heavy Duty Manifolds (Right)	M2-X-MAN-42E-R
Line pressure regulator for Heavy Duty Manifolds (For NIT, Left)	M2-X-MAN-42E-LN
Line pressure regulator for Heavy Duty Manifolds (For NIT, Right)	M2-X-MAN-42E-RN
Operating pressure regulator for HD Manifolds (Left)	M3-X-MAN-18DL-L
Operating pressure regulator for HD Manifolds (Right)	M3-X-MAN-18DL-R
Repair kit line pressure regulator - HD	M2-REG700-RK
Repair kit operating pressure regulator	M3-REG250-RK-DL

Ordering Information

Control Cabinet Parts List

DESCRIPTION	MODEL NUMBER
Intermediate check valve for all gases	M-X-MAN-33B
Operating pressure relief valve Nitrogen	M-X-IN-72W-350
Operating pressure relief valve Oxy, N ₂ O, Air & CO ₂	M-X-IN-72W-350
Line pressure relief valve for Nitrogen	M-X-IN-72W-225
Line pressure relief valve for Oxy, N ₂ O, Air & CO ₂	M-X-IN-72W-075
Plug & chain assembly - Air	M-X-HB-NUT-AIR
Plug & chain assembly - CO ₂	M-X-HB-NUT-CO2
Plug & chain assembly - N ₂ O	M-X-HB-NUT-N2O
Plug & chain assembly - Nit	M-X-HB-NUT-NIT
Plug & chain assembly - Oxy	M-X-MAN-36
Copper pigtail c/w check valve - Air	M-X-HB-PTC-AIR
Copper pigtail c/w check valve - CO ₂	M-X-HB-PTC-CO2
Copper pigtail c/w check valve - N ₂ O	M-X-HB-PTC-N2O
Copper pigtail c/w check valve - Nit	M-X-HB-PTC-NIT
Copper pigtail c/w check valve - Oxy	M-X-HB-PTC-OXY
Stainless pigtail c/w check valve - Air	M-X-HB-PTS-AIR
Stainless pigtail c/w check valve - CO ₂	M-X-HB-PTS-CO2
Stainless pigtail c/w check valve - N ₂ O	M-X-HB-PTS-N2O
Stainless pigtail c/w check valve - Nit	M-X-HB-PTS-NIT
Extension wall support	M-X-HB-WLBRKIT
High pressure inlet valve	M-X-HB-HPVLV-A
Display circuit board assembly	M3-LED-DLCB
Manifold power supply	M2-X-POWER
Solenoid valve	M3-X-MAN-SOLVLV

Appendix A

Manifold Internal Layout

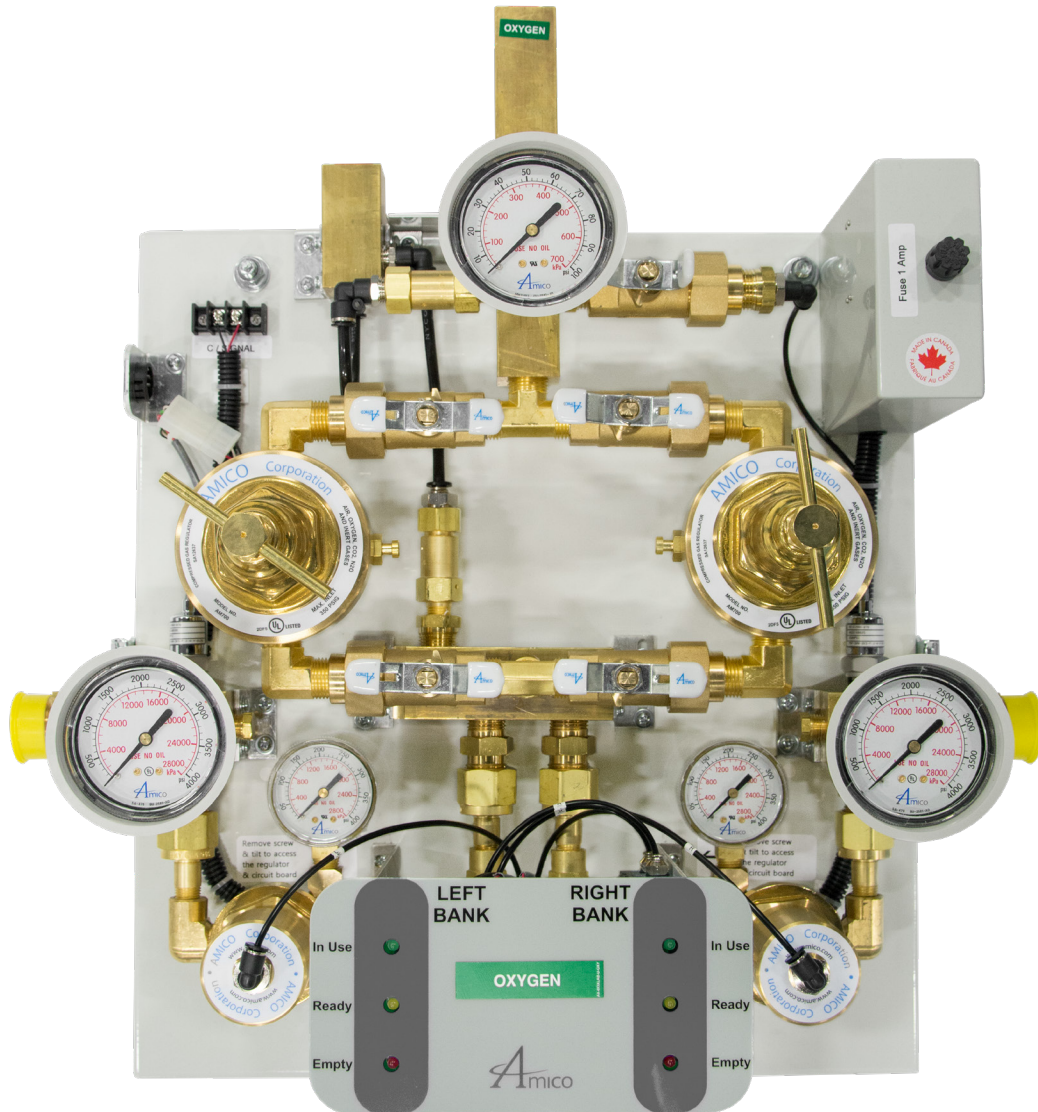

Appendix B

Piping Schematic Diagram

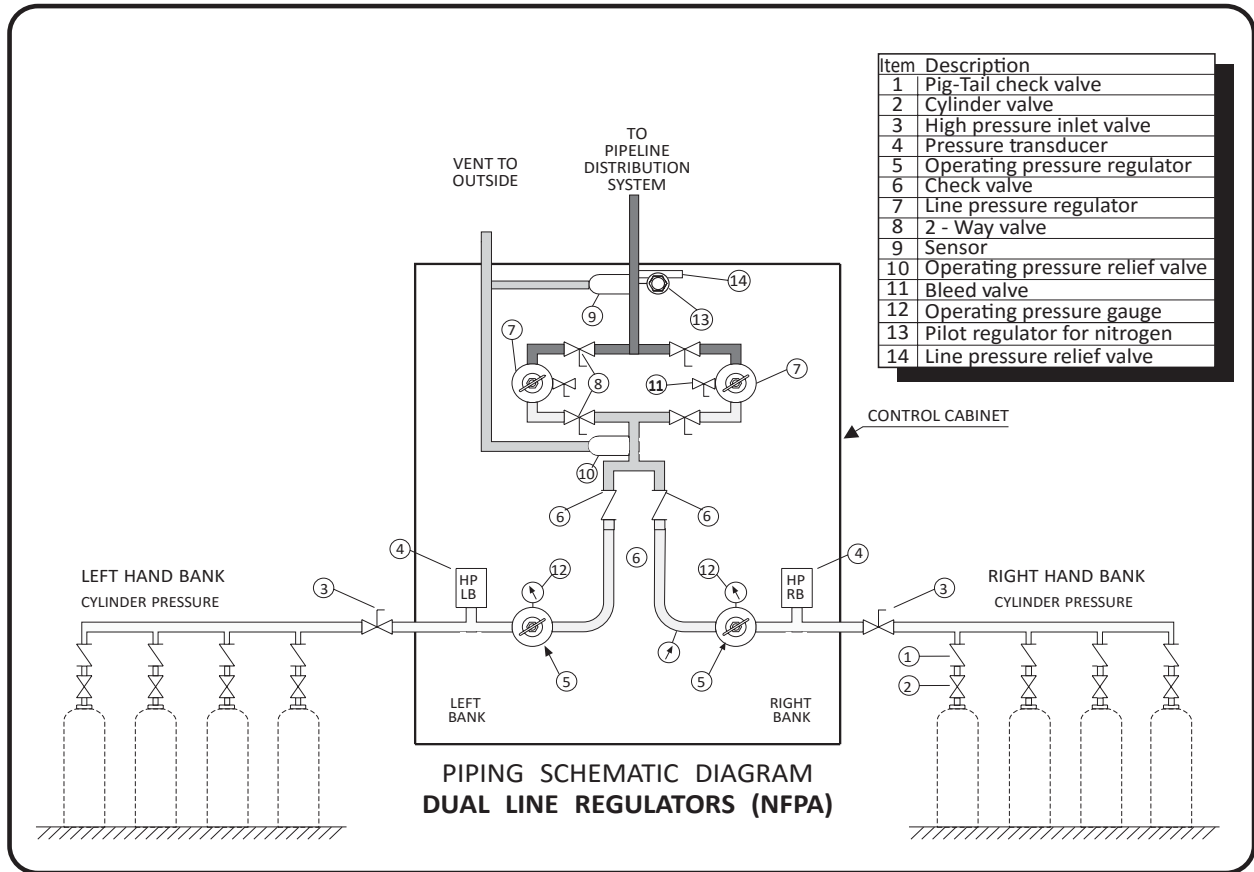

Appendix C

Wiring Schematic Heater Units

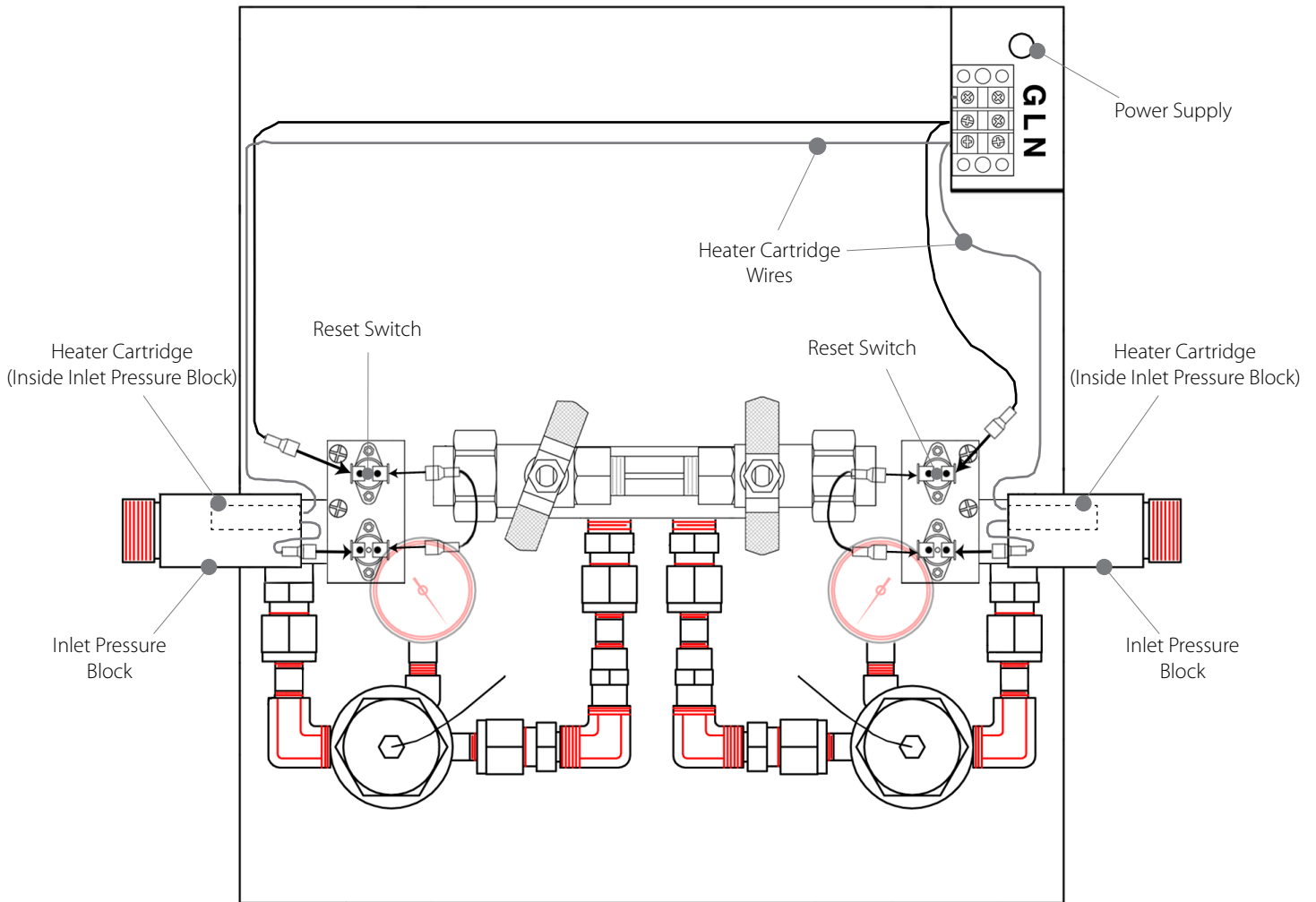

The heaters normally switch on when the temperature drops below 24°C or 75°F. If the temperature exceeds 65-75°C or 160-175°F, the Heater reset switch will trip and the heaters will automatically switch off. To reset the heaters, remove the heater covers and press the red button on the reset switch to activate. When the heaters are "In Use" or switched on, it will draw up to 3 amps of current. The heater cartridge is 200 watts (each side). Normally both sides do not switch on together, it depends on the flow of gas or climatic conditions.

Appendix D

Electrical Wiring Diagram

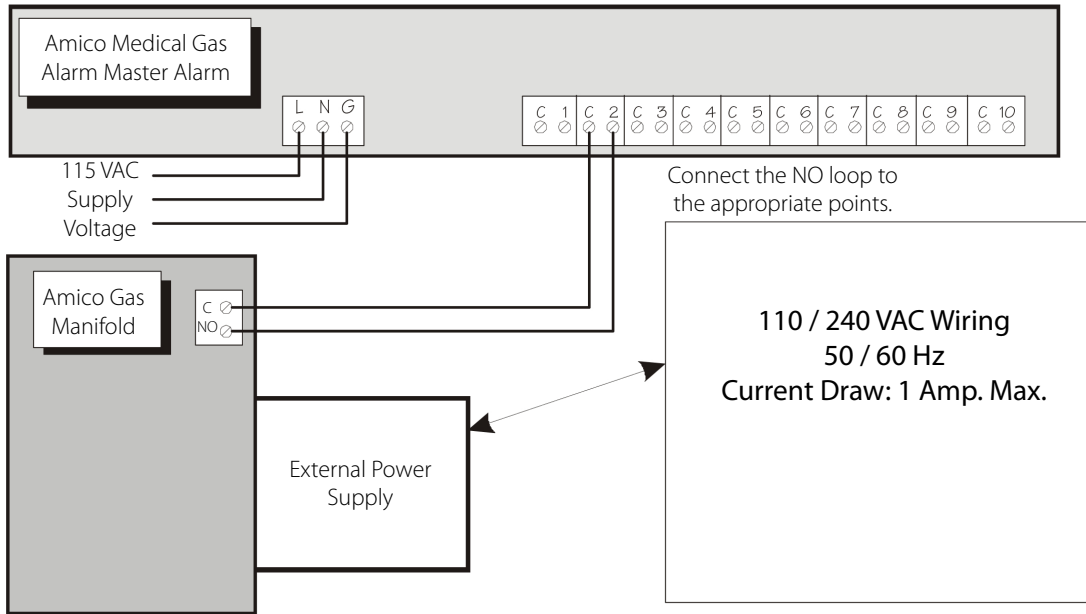

Appendix E

Control Cabinet Wiring Diagram

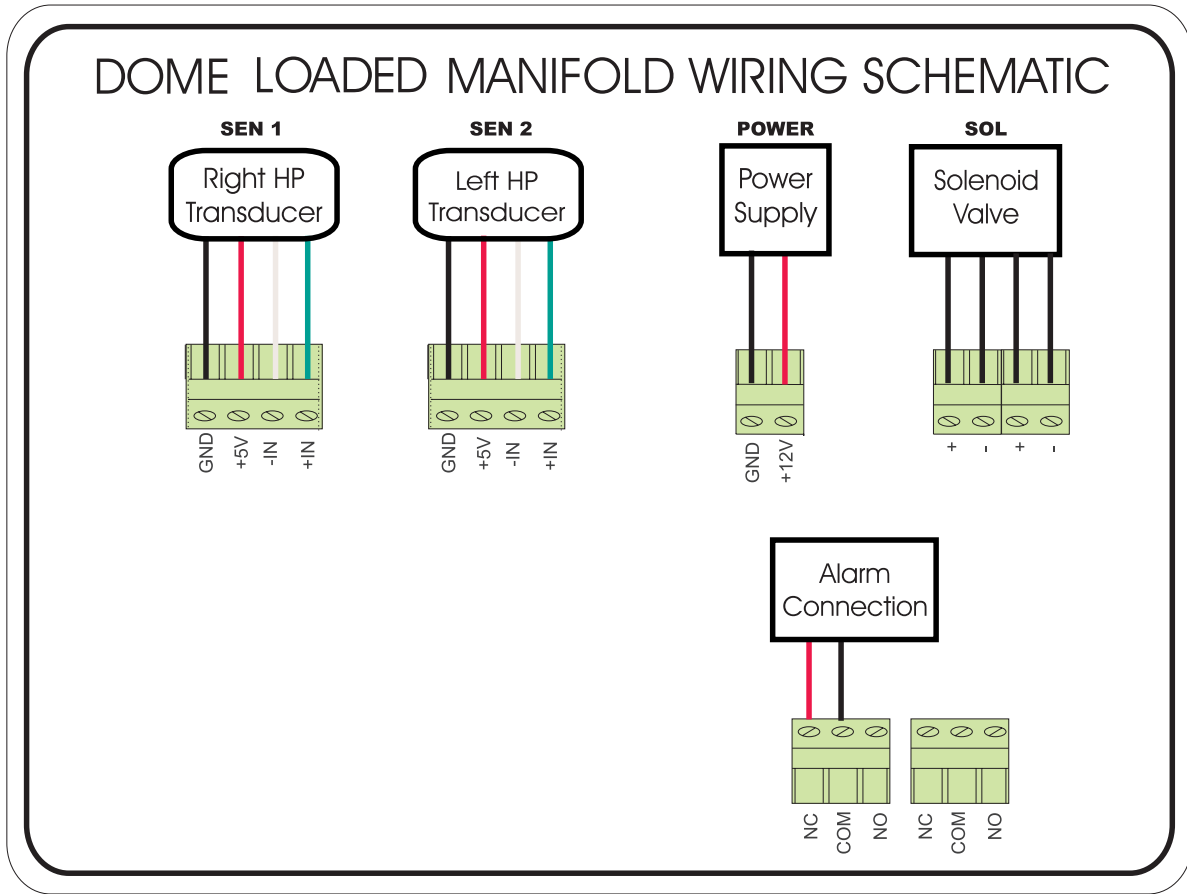

Appendix F

Staggered Header Bar

Inch
[mm]

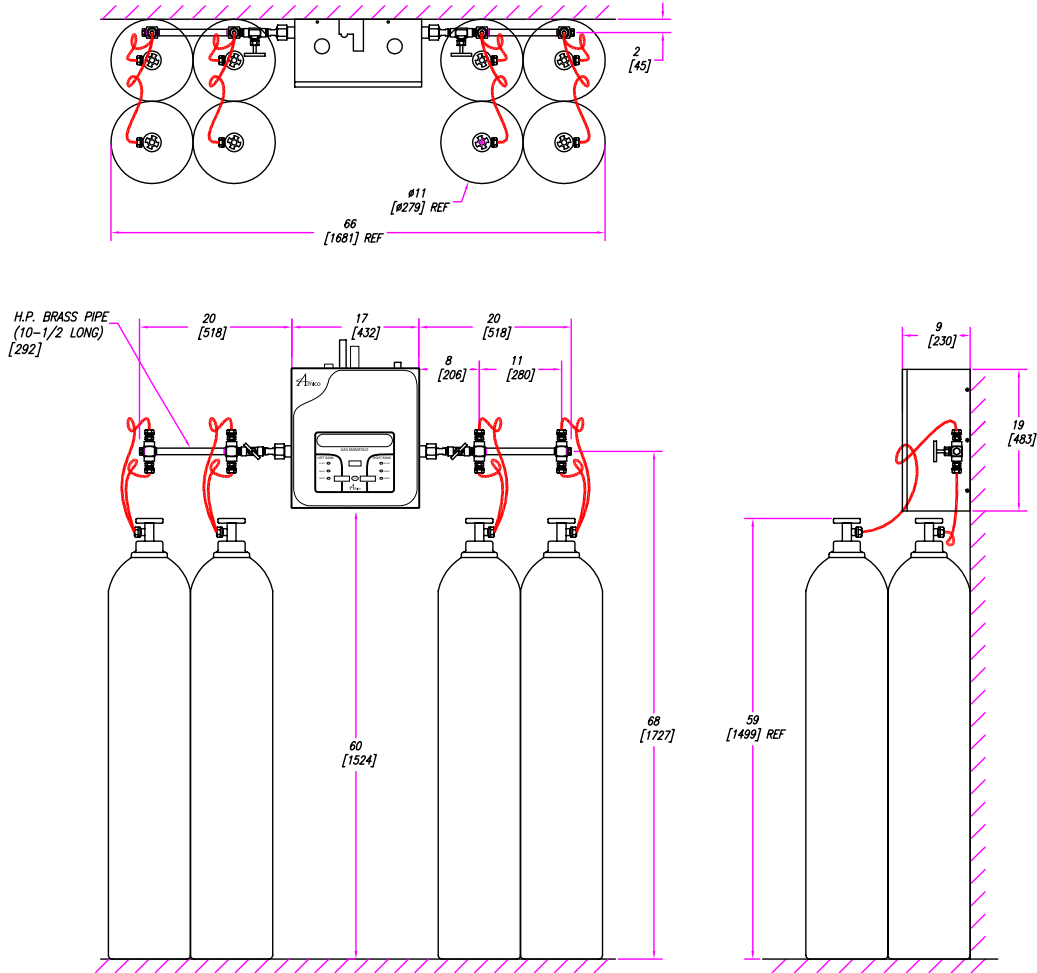

STANDARD 4X4 DOME MANIFOLD LAYOUT WITH STAGGERED HEADER BARS

No. of Cylinders	Overall Length
2	42 [1067]
4	42 [1067]
6	64 [1626]
8	64 [1626]
10	86 [2184]

No. of Cylinders	Overall Length
12	86 [2184]
14	108 [2743]
16	108 [2743]
18	130 [3302]
20	130 [3302]

Appendix G

Straight Header Bar Setup

Inch
[mm]

NOTE:
DIMENSIONS ARE BASED ON
APPROXIMATE DISTANCES!

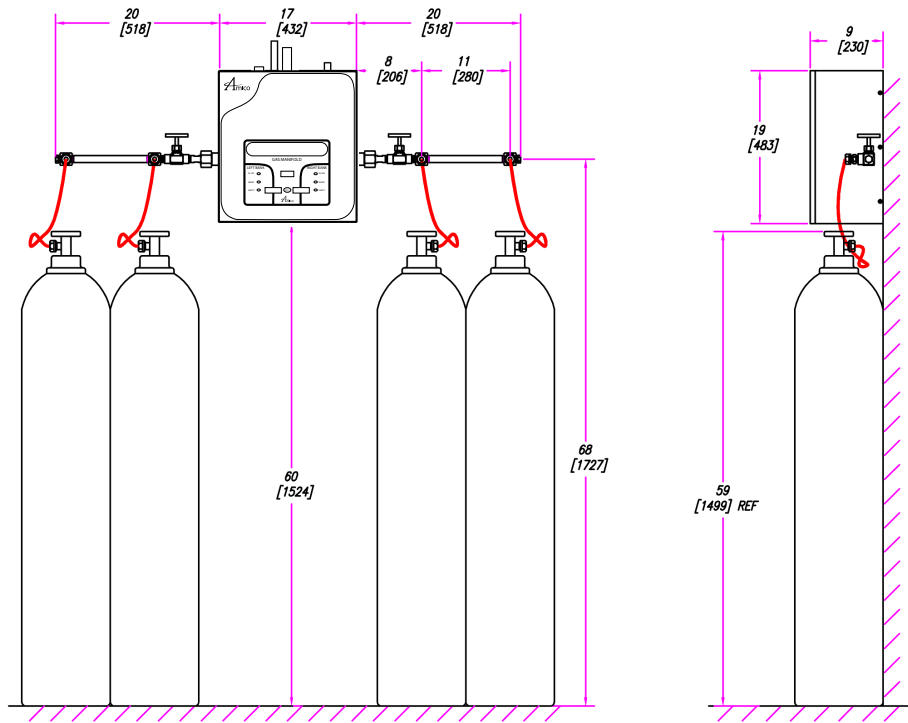
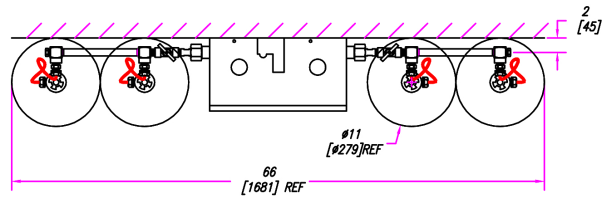

STANDARD 2X2 DOME MANIFOLD WITH STRAIGHT HEADER BARS LAYOUT

Appendix H

Optional Header Bar Setup

Inch
[mm]

NOTE:
DIMENSIONS ARE BASED ON
APPROXIMATE DISTANCES!

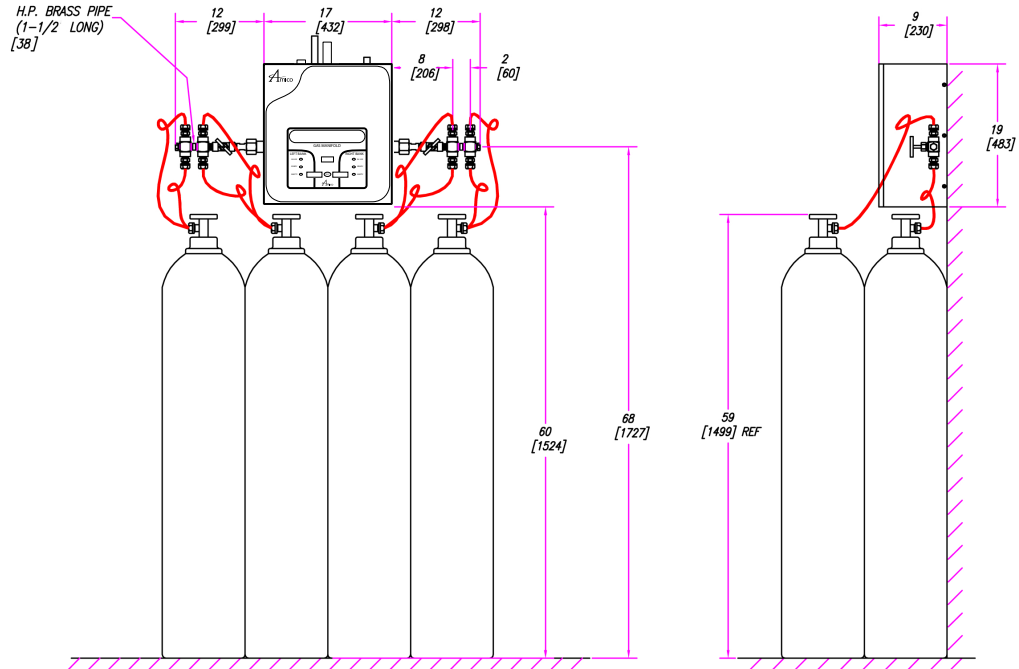
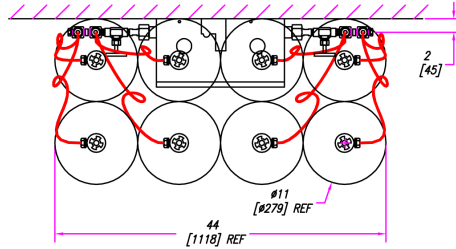

OPTIONAL 4X4 NFPA DOME MANIFOLD LAYOUT WITH STAGGERED HEADER BARS

Standard Manifold Flow Rates

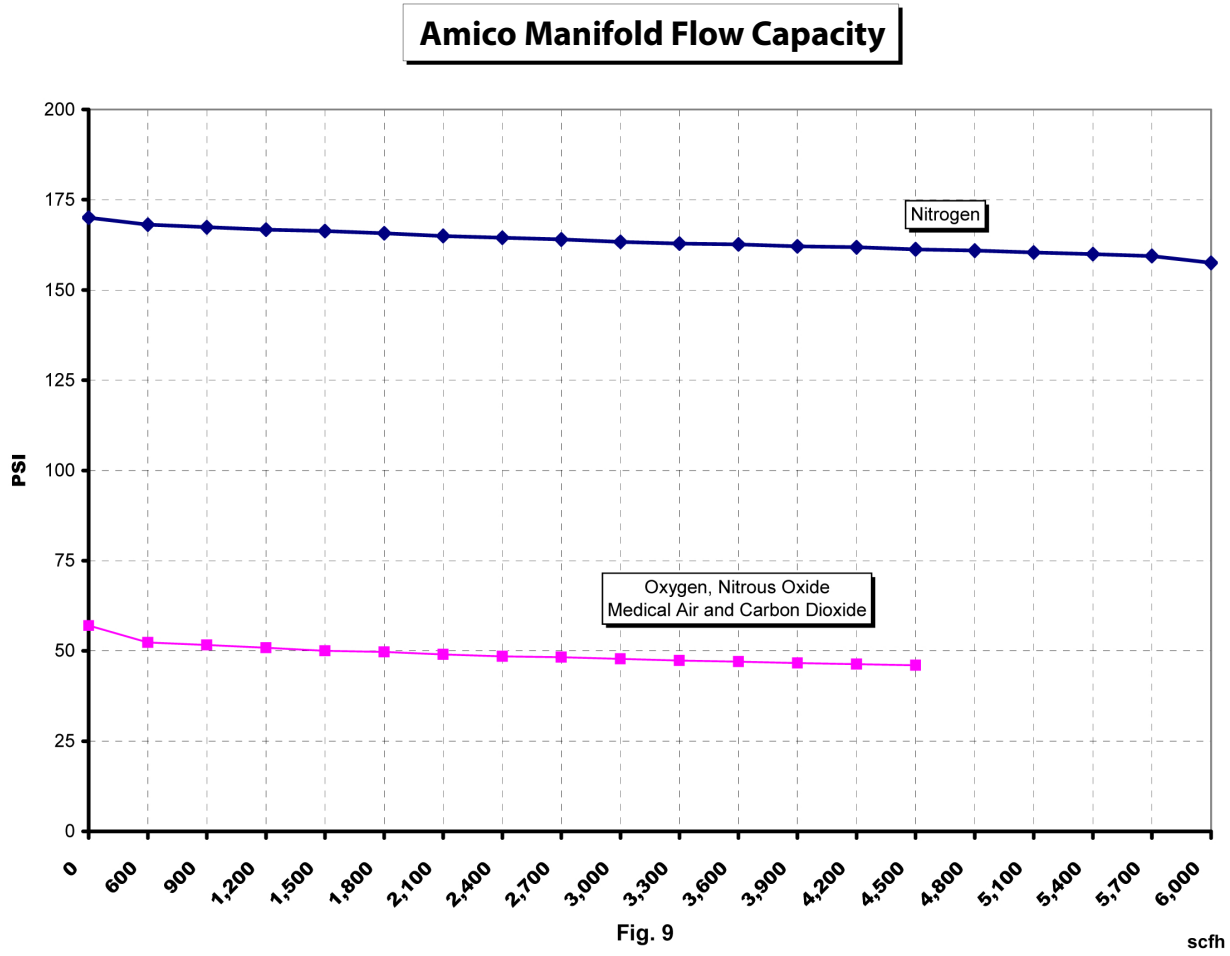

www.amico.com

Amico Corporation | 85 Fulton Way, Richmond Hill, ON L4B 2N4, Canada
71 East Industry Court, Deer Park, NY 11729, USA
Toll Free Tel: 1.877.462.6426 | Tel: 905.764.0800 | Fax: 905.764.0862
Email: info@amico.com | www.amico.com

