

Relief Valve

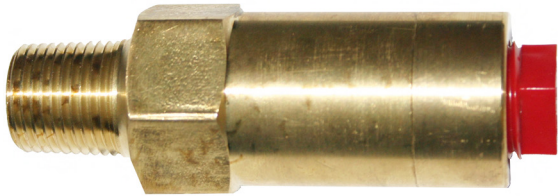

Features:

- Accurate cracking pressure
- Temperature range: -100 °F to +165 °F
-73 °C to +74 °C
- Pressure settings: 75, 150, 200, 225, 250, 350 and 375 psi
- Orifice size: 5/16" dia
- Flow co-efficient (cv factor): 1.3 type
- Seat material: Viton

Amico products comply with NFPA 99.

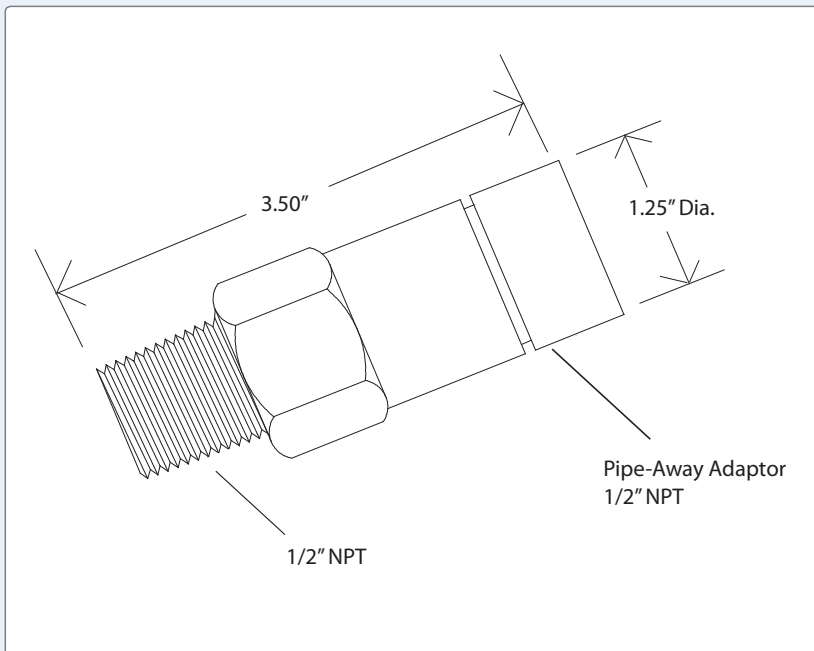

Model Numbers

75 psi = **M-X-MAN-72W-075**

150, 110, 125 psi = **M-X-MAN-72W-150**

250, 225, 200 psi = **M-X-MAN-72W-200**

Note: The above relief valves include pipe-away adaptor.

Model Numbers

375psi = **M-X-MAN-72W-300**

450psi = **M-X-MAN-72W-500**

Note: The above relief valves requires pipeaway adaptor **M-X-PIPEAWAY-GNT** to be ordered separately.

