

Technical Specifications

1/2" to 1 1/2" Zone Indicator Panel Box Assembly

Inch
[mm]

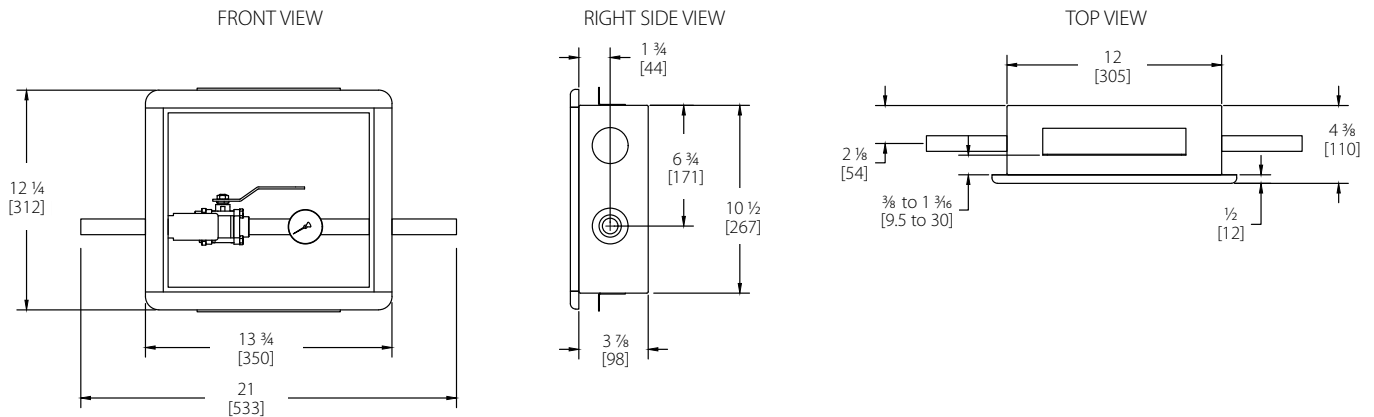

2" Zone Indicator Panel Box Assembly

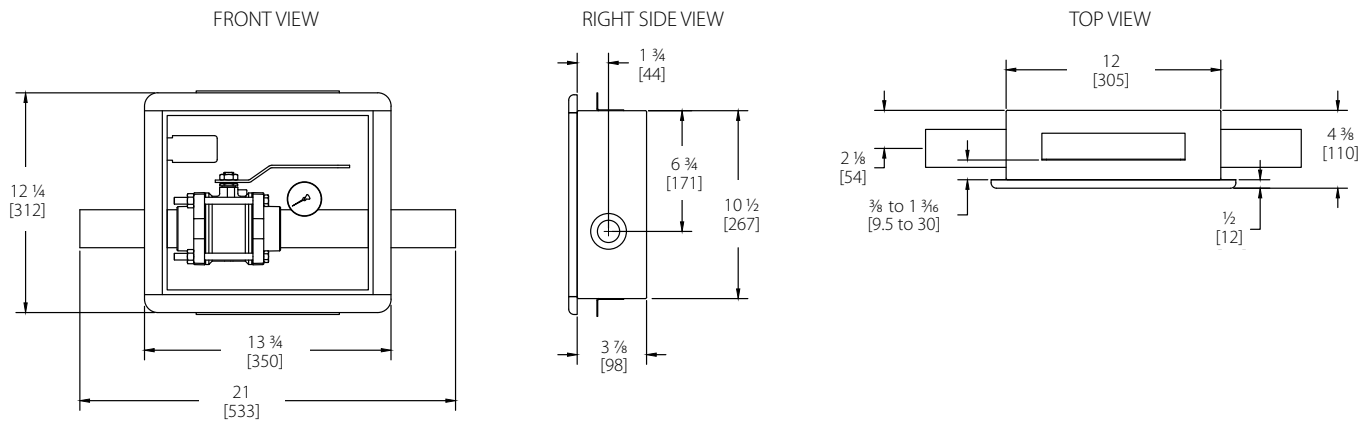

Model Numbers

The Letter "L" Defines the Language:

English (NFPA)	=	U
Spanish (NFPA)	=	S
English (CSA/ISO)	=	E
French (CSA/ISO)	=	F

ZIL-MX

Replace "X" with the Size Required:

1/2"	=	1
3/4"	=	2
1"	=	3
1-1/4"	=	4
1-1/2"	=	5
2"	=	6
2-1/2"	=	7
3"	=	8

Monitoring (gauge optional 100, 300, VAC) = M

Example:

Box with gauge, English (Opaque Window) and a 1-1/2" shut-off monitoring = **ZIE-M5**

NOTE:

All zone shut-offs are full port.
The 1/2" to 2" shut-off shall be assembled in a 3-7/8" deep box.
The 2-1/2" or 3" shut-off shall be assembled in a 6-11/16" deep box.
For sizes 1/2" to 1-1/2", the shut-off will be installed into a 2 gang box by turning the box upside down. The shut-off is mounted and the extra holes are then plugged as shown on 1/2" to 1-1/2" zone indicator panel assembly drawing.