

### Important Safety Instructions

When using electrical equipment, basic safety precautions should always be followed including the following:

#### Read And Follow All Safety Instructions

1. **Warning:** This luminaire must be installed in accordance with the NEC or your local electrical code. If you are not familiar with these codes and requirements, consult a qualified electrician. *Attention: Ce luminaire doit être installé conformément au NEC ou à votre code électrique local. Si vous n'êtes pas familier avec ces codes et exigences, consultez un électricien qualifié.*
2. **Warning:** This luminaire must be installed in accordance with the NEC or your local electrical code. If you are not familiar with these codes and requirements, consult a qualified electrician. *Attention: Ce luminaire doit être installé conformément au NEC ou à votre code électrique local. Si vous n'êtes pas familier avec ces codes et exigences, consultez un électricien qualifié.*
3. **Warning:** This equipment is not for use in hazardous combustible atmospheres as defined by the National Electrical Code. *Avertissement: Cet équipement ne doit pas être utilisé dans des atmosphères combustibles dangereuses telles que définies par le National Electrical Code.*
4. **Danger:** Risk of shock - Disconnect power before installation. *Danger: Risque de choc – Couper l'alimentation avant l'installation.*
5. Type Non-IC Recessed. *Garnitures de type Non-IC.*
6. Inherently protected. *Protection inhérente.*
7. Dry locations only. *Pour emplacements secs seulement.*
8. Access above ceiling required. *Accès requis au-dessus du plafond.*

### Save These Instructions For Future Reference

#### Installation:

**Warning:** Fixtures should be supported independently of the ceiling grid. Ceiling structure should be installed to withstand a load rating of 4lbs/sqft. Ceiling mains at the IDP area to be run every 24in. and ceiling grid mains should be ran the shortest distance possible.

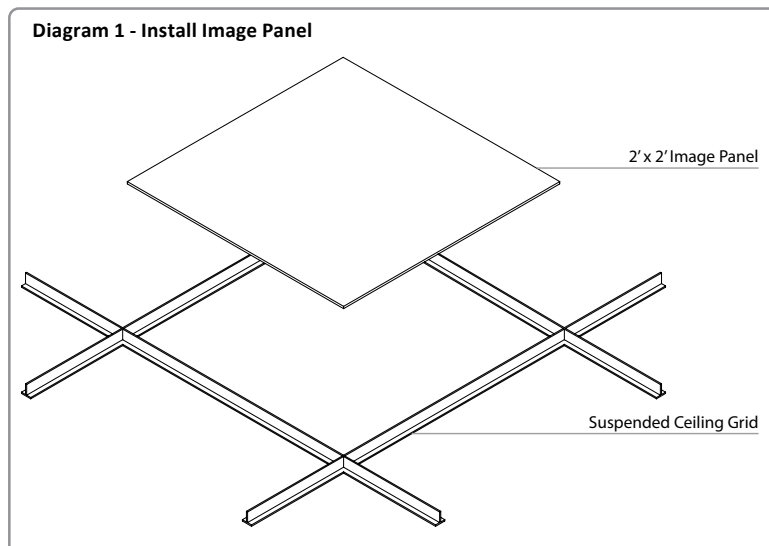

1-07-000322 - IDP22 with Riser

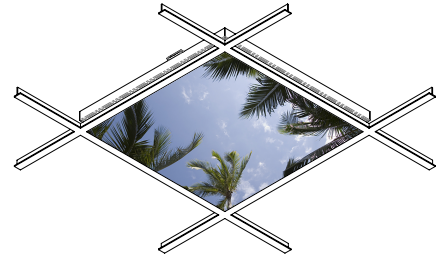

Includes:

1-07-000321 - 50K Ethernet Connection

\*Consult factory for custom sizes

**NOTE:** There are multiple configurations possible for the IDP. Illustrated below is an example of a standard 2' x 2' installation. IDP's can be arranged in arrays of various shapes using multiple panels. Questions with a specific installation should be directed to the Customer Site Installation drawings or to your Sales Representative.

#### Step 1:

Turn off the power supply.

#### Step 2:

Place the provided Image Panel into the existing ceiling grid as shown in **Diagram 1**. If there is more than one image, ensure they are laid out in the correct configuration and the glossy side of the image is facing the room side.

#### Step 3:

Place the riser on to the ceiling grid above the Image Panel with the narrower opening facing the room side as shown in **Diagram 2**.

**Step 4:**

Place the IDP22 into the riser as shown in **Diagram 3** aligning the junction box with the incoming supply wire and the other luminaires if applicable.

**Step 5:**

Wire the IDP22 per the **Electrical Connections** section.

**Step 6:**

Turn on the power supply.

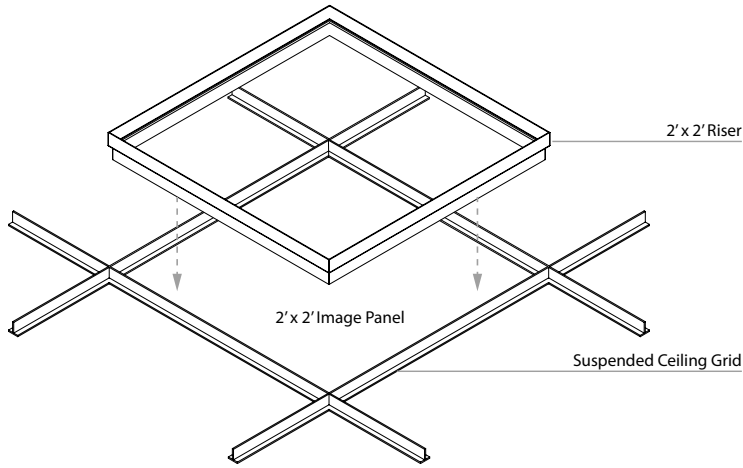
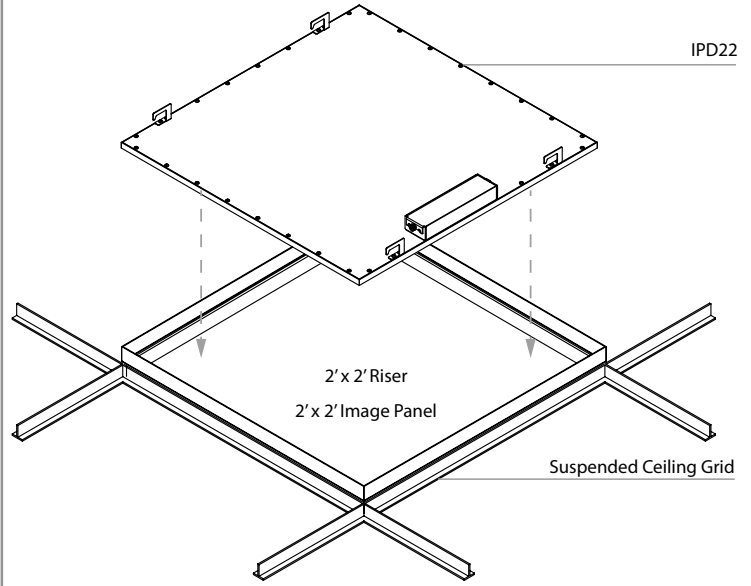
**Diagram 2 - Install Riser****Diagram 3 - Install IDP22****Electrical Connections****Step 1:**

Remove the Junction Box cover.

**Step 2:**

Make the following Electrical Connections.

**ETHERNET WIRING:**

1. Connect the CAT5, CAT5E or CAT6 Ethernet Cable from the filter pack when using a 12 Channel Driver or from the output port when using a PSF16 to the "In" port in the junction box.
2. Connect the CAT5, CAT5E or CAT6 Ethernet Cable from the "Out" port of the first luminaire to the "In" port of the next Ethernet luminaire.
3. All wires must be terminated to Standard T568B on both ends.
4. Four (4) luminaires maximum per CAT output from 12/16 Channel Driver.

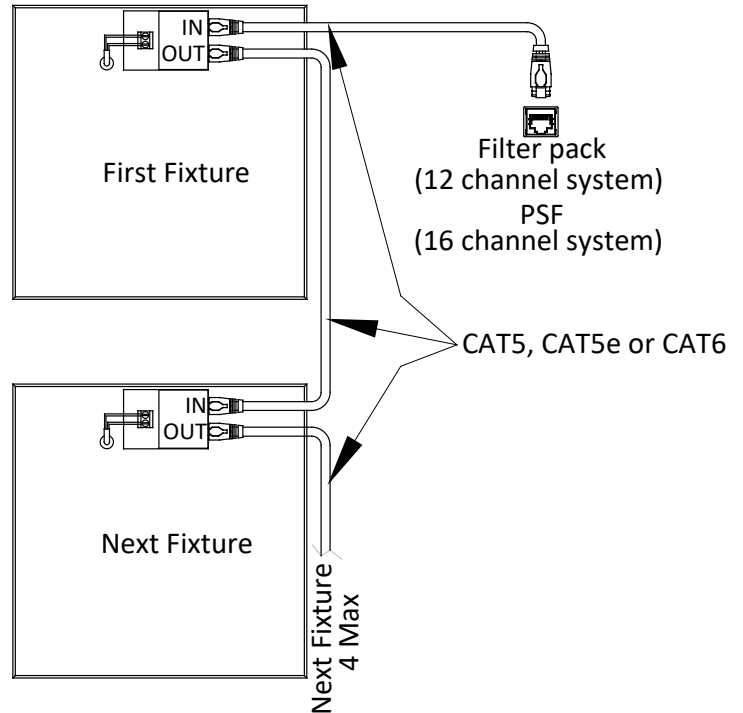
**Directive 2012/19/EU (WEEE - Waste Electrical and Electronic Equipment): Information for Users**

This product complies with EU Directive 2012/19/EU. The crossed out wheeled bin symbol on the article means that at the end of its useful lifespan, this product must not be disposed of with your other household or municipal waste. This product has required the extraction and use of natural resources for its production. It may contain hazardous substances that could impact health and the environment if not properly disposed. In order to avoid dissemination of those substances in our environment and to diminish the pressure on the natural resources, the user is responsible for delivering the appliance to an appropriate collection facility at the end of its useful lifespan. The separate collection and recycling of your waste equipment at the time of disposal will help conserve natural resources and ensure that it is recycled in a manner that protects human health and the environment. For more information on available collection facilities contact your local waste collection service or the place of purchase.