

# Product Overview

## Competitor Trolleys

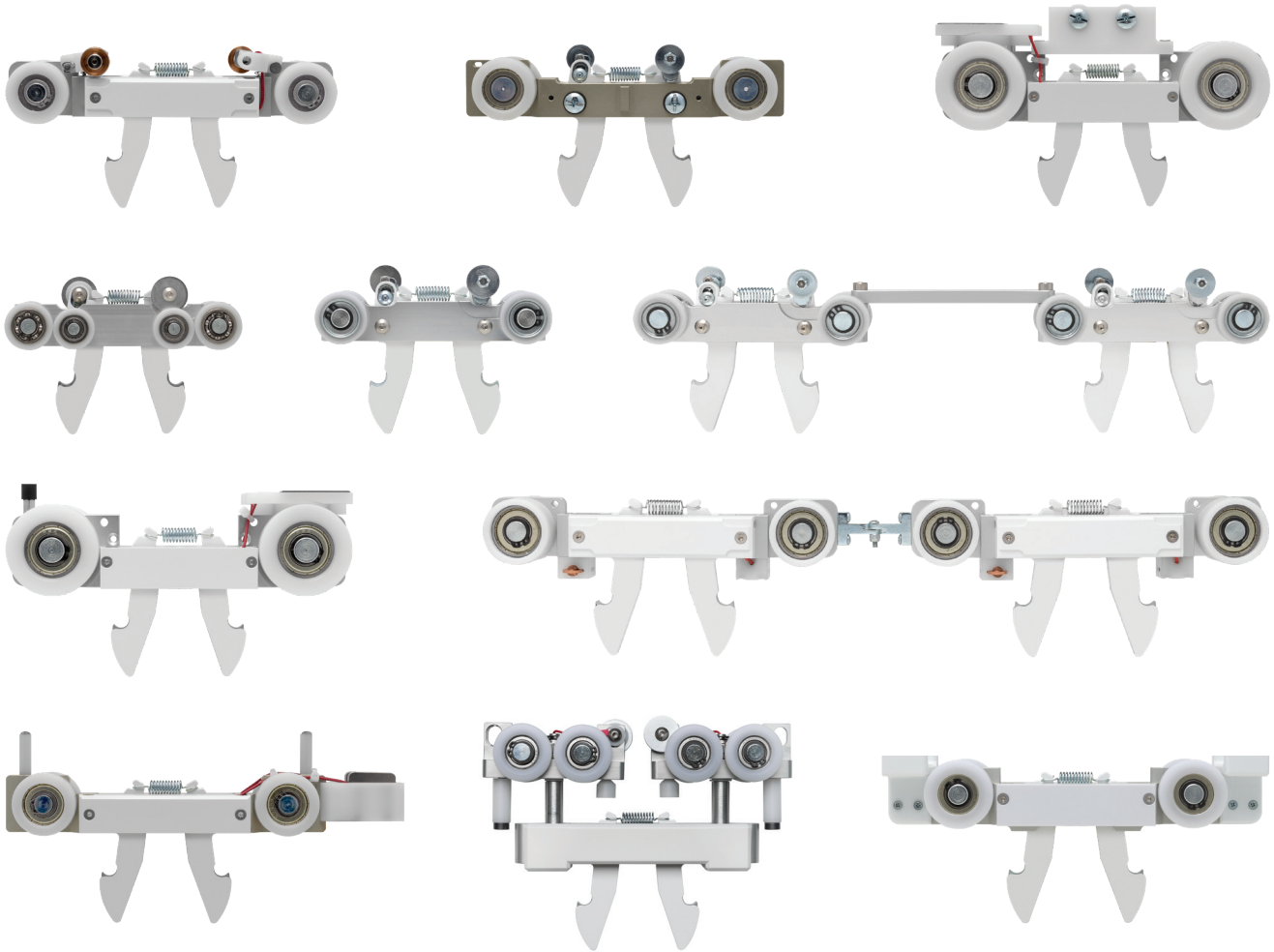

GO-LIFT-QR-TRLY-ARJ-ASSY  
 GO-LIFT-1000-ARJ-TRLY-ASY  
 GO-LIFT-QR-TRLY-PT-ASSY-ARJO  
 GO-LIFT-QR-TRLY-BHM-ASSY  
 GO-LIFT-QR-GMI-TRLY-HSC  
 GO-LIFT-QR-TRLY-GH2-UNIV-ASSY  
 GO-LIFT-QR-TRLY-GM-ASSY  
 GO-LIFT-QR-TRLY-HCR-ASSY

GO-LIFT-QR-TRLY-INVA-ASSY  
 GO-LIFT-QR-TRLY-JRNS-C-ASSY  
 GO-LIFT-1000-TRLY-JRNS  
 GO-LIFT-QR-TRLY-LIKO-ASSY  
 GO-LIFT-QR-TRLY-SS-HSC-ASSY  
 GO-LIFT-QR-TRLY-STEISS-ASSY  
 GO-LIFT-QR-TOLLOS-CC  
 GO-LIFT-QR-TOLLOS-EC

GO-LIFT-QR-TOLLOS-EC-H  
 GO-LIFT-1000-QR-TRLY-TOLLOS-EC  
 GO-LIFT-QR-TRLY-WGCC-ASSY  
 GO-LIFT-QR-TRLY-WGCC-ST-ASSY  
 GO-LIFT-QR-TRLY-WGEC-ASSY  
 GO-LIFT-QR-TRLY-WGEC-ST-ASSY  
 GO-LIFT-1000-WGN-CC-TRLY  
 GO-LIFT-1000-WGN-EC-TRLY



# Amico Competitor Trolleys

The Amico Competitor trolleys serve as a mounting point for the Amico GoLift (maximum capacity 700lbs per trolley). The trolleys have free turning wheels mounted on ball bearings that support the weight of the lift and patient to guide the two through a track system.

The trolley adaptors are specially made to fit into existing track systems made by a variety of different manufacturers and work with a variety of different charging systems (See charts below). Being able to retrofit the GoLift into existing track systems allows for hospitals and homes to update their lifts without having to tear down the existing track systems. This saves on cost and downtime where the lifts are not usable.

## Lift Attachment/Detachment

To detach the lift from the trolley, first support the weight of the lift before squeezing the two buttons located on the top of the lift to release the lift from the trolley latches (only applies to quick release models).

The two locking screws on the lift must be removed in order to insert the trolley. The screws can be left off to retain the toolless install or reinserted to lock the trolley in place for extra security against tampering.



# Amico Competitor Trolleys

## To Retrofit:

1. The **old lift** and **power supply** must be replaced with the Amico GoLift and Amico power supply.  
**NOTE:** The Amico GoLift will **NOT** work with the existing power supply.
2. Remove one of the existing end stops (Amico does not supply end stops, the existing ones can be reused).
3. Insert the Amico competitor trolley into the track.
4. Reinsert the existing end stop.
5. Attach the barrel plug supplied with the trolley to the charge strips, depending on what the existing charging method is (most of the time the end stop supplies power to the charge strips):
  - a. The barrel plug supplied with the trolley can be directly attached to the charge strips.
  - b. The barrel plug supplied with the trolley can be spliced into existing wires that connect to the charge strips.
  - c. The barrel plug supplied with the trolley can be attached directly into the end stop.
  - d. In cases where there is no charging set up, the handset charging version of the Amico lift can be purchased and the power supply can plug directly into a plug on the hand control in order to charge the lift.
6. Plug the power supply into the outlet and connect the barrel plug end to the other end of the barrel plug wire that was installed in step 5.



### **WARNING:**

To avoid choosing the wrong adaptor, please send a picture of the profile of the track to your sales rep. Amico cannot take responsibility for any wrong parts ordered without this confirmation.

The maximum capacity of the existing track must be observed and followed. The GoLifts can be down rated to match the track maximum capacity. A certifying load test must be performed when retrofitting the GoLift.

Verify that all functions of the lift including charging are working correctly.

# Amico Competitor Trolleys

## ARJO/SAVARIA TROLLEY: GO-LIFT-QR-TRLY-ARJ-ASSY

700lbs Capacity Arjo/Savaria Trolley. Quick Connect, in-rail charge through strips.

**NOTE:** Charge strips must be purchased through Amico for the system to have in-rail charge as part of the Arjo power supply (GO-LIFT-PS-ARJ-ASY) package. New charge strips will allow for end-stop charge only and do not provide continuous charge.

### Compatible With:

- Straight Track
- Curved Track
- Gantry

### Not Compatible With:

- Curtain Jumping
- Existing Dock Charging

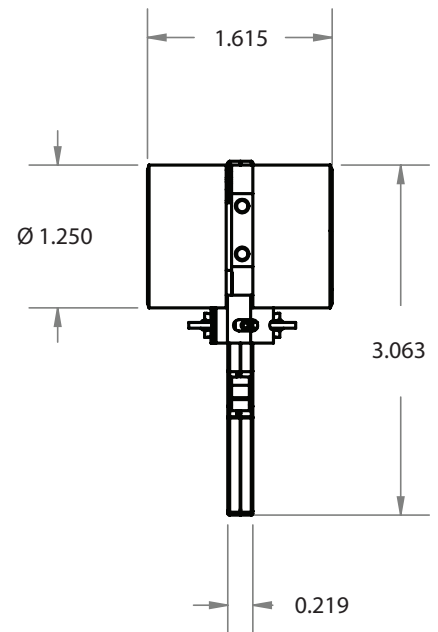
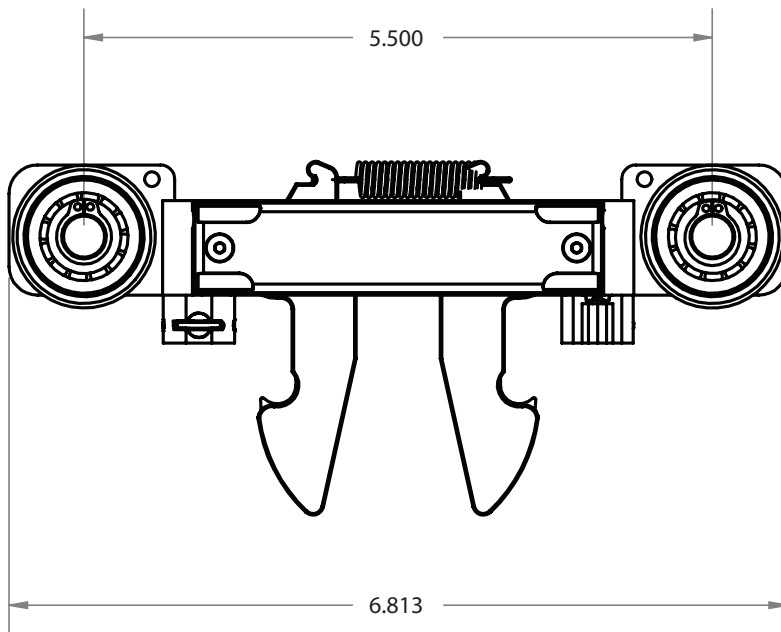
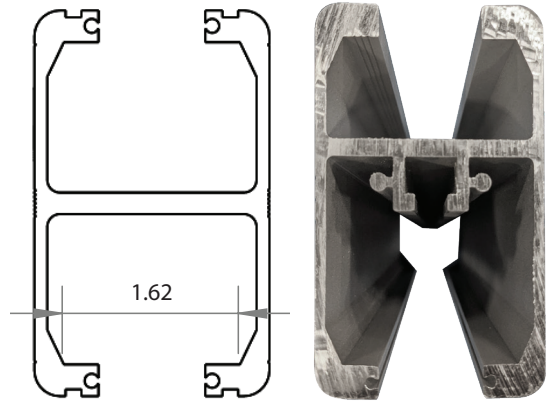
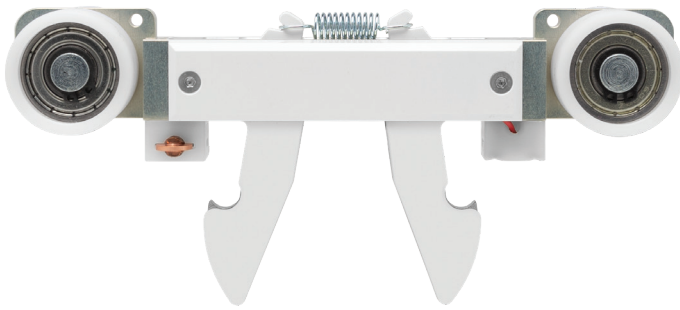

\*Dimensions are shown in inches

# Amico Competitor Trolleys

## ARJO/SAVARIA TROLLEY: GO-LIFT-1000-ARJ-TRLY-ASY

1000lbs Capacity Arjo/Savaria Trolley. Quick Connect, in-rail charge through strips.

**NOTE:** Charge strips must be purchased through Amico for the system to have in-rail charge as part of the Arjo power supply (GO-LIFT-PS-ARJ-ASY) package. New charge strips will allow for end-stop charge only and do not provide continuous charge.

### Compatible With:

- Straight Track
- Curved Track
- Gantry

### Not Compatible With:

- Curtain Jumping
- Existing Dock Charging

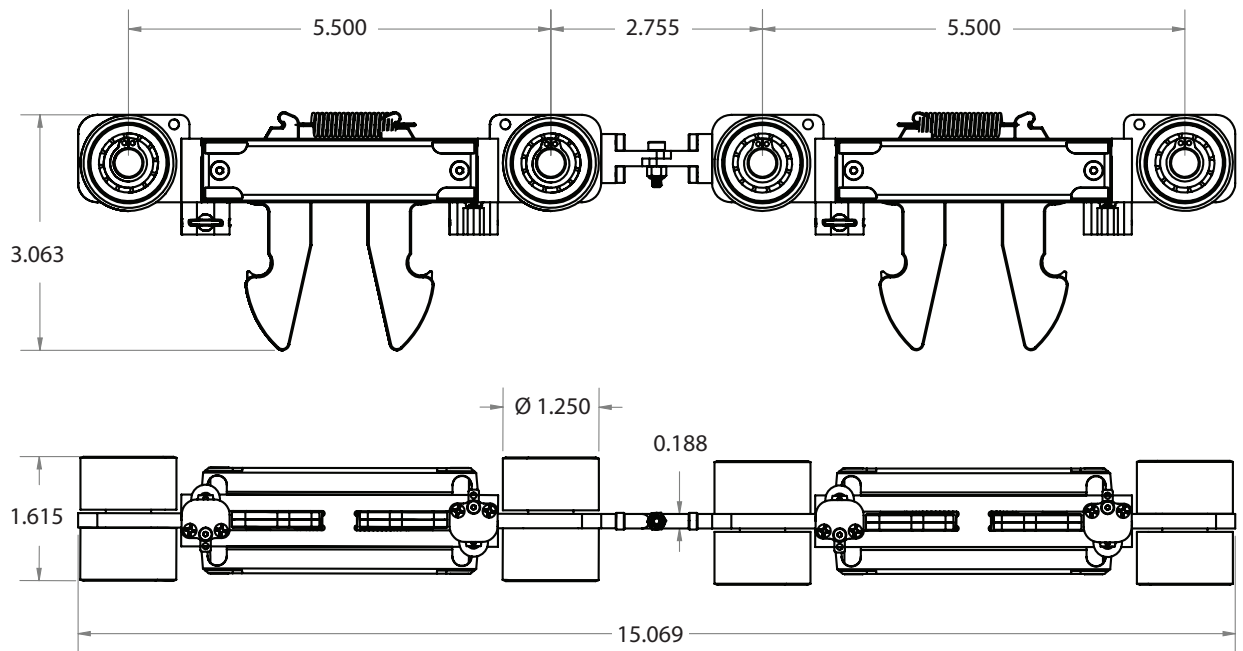
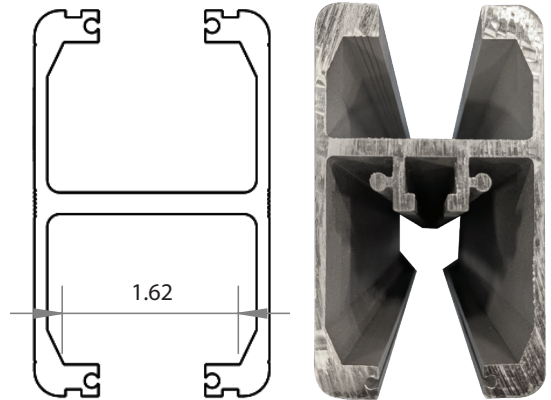

\*Dimensions are shown in inches

# Amico Competitor Trolleys

## ARJO/INNOMEDIC/SAVARIA POWER TRAVERSE TROLLEY: GO-LIFT-QR-TRLY-PT-ASSY-ARJO

700lbs Capacity Innomedic Power Traverse Trolley. Quick Connect, in-rail charge through strips.

\*See Amico Power Traverse Product Overview for more details.

**NOTE:** Charge strips can be purchased as a set with the part number "GO-LIFT-PS-ARJ-ASY" which comes with a set of 1' charge strips connected to the Amico power supply.

### Compatible With:

- Straight Track
- Curved Track (Innomedic Track Only)
- Gantry
- Curtain Jumping

### Not Compatible With:

- Existing Dock Charging

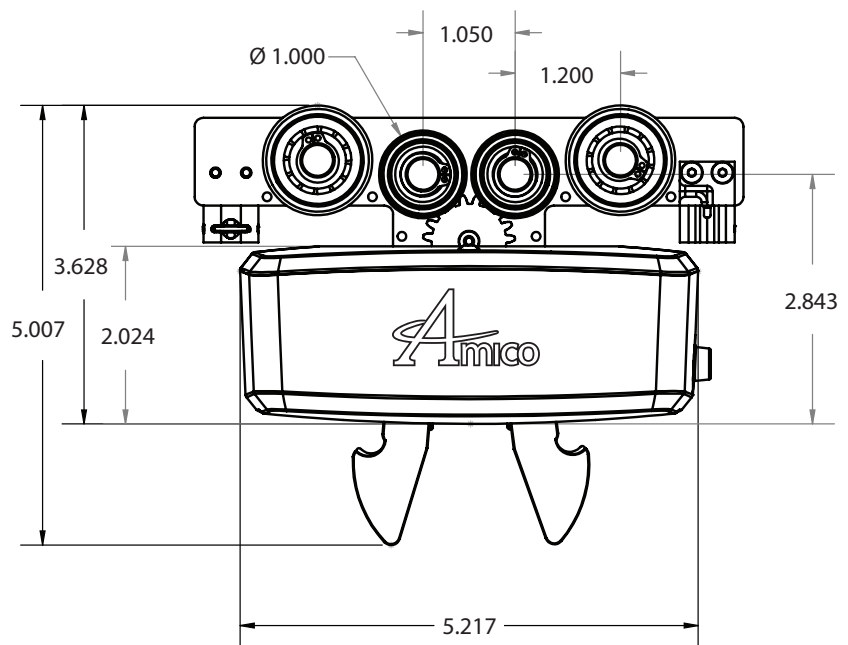
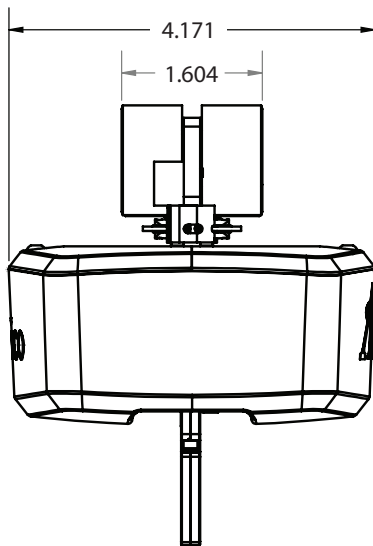
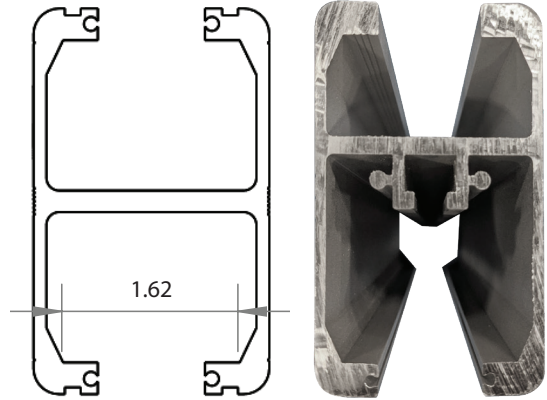

\*Dimensions are shown in inches

# Amico Competitor Trolleys

## BHM TROLLEY: GO-LIFT-QR-TRLY-BHM-ASSY

700lbs Capacity BHM Trolley. Quick Connect, in-rail end stop dock charge.

### Compatible With:

- Straight Track
- Gantry

### Not Compatible With:

- Curtain Jumping
- Curved Track

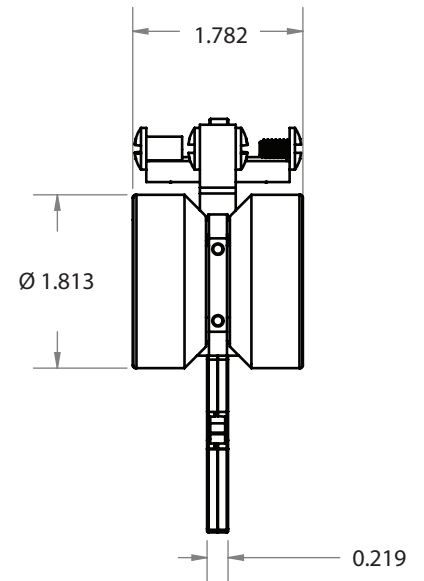
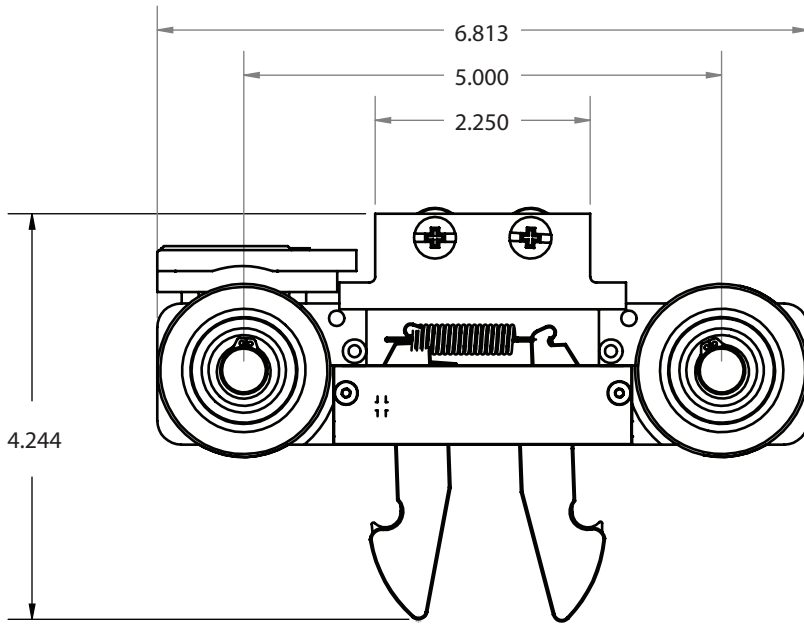
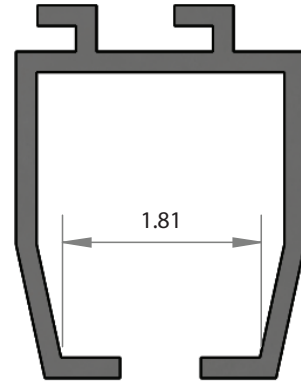
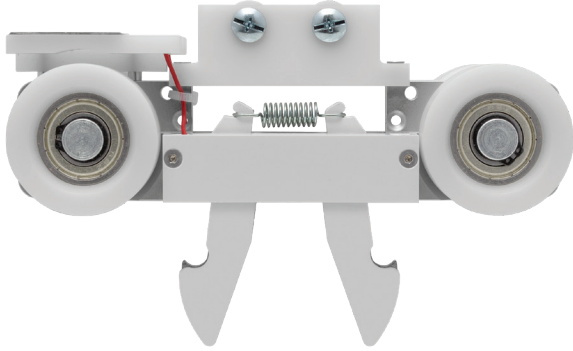

\*Dimensions are shown in inches

# Amico Competitor Trolleys

## GEMINI/LIFTECH TROLLEY: GO-LIFT-QR-GMI-TRLY-HSC

700lbs Capacity Gemini/Liftech Trolley. Quick Connect, handset charge.

### Compatible With:

- Straight Track
- Gantry

### Not Compatible With:

- Curtain Jumping
- Curved Track

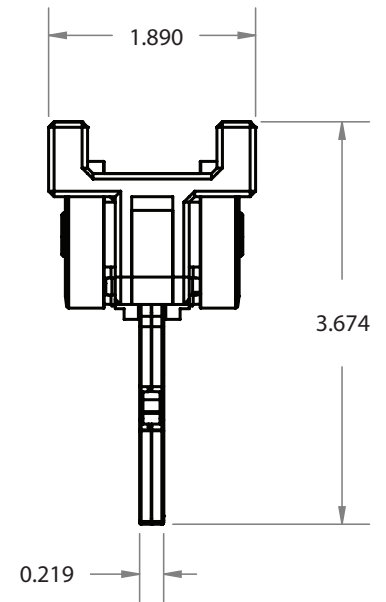
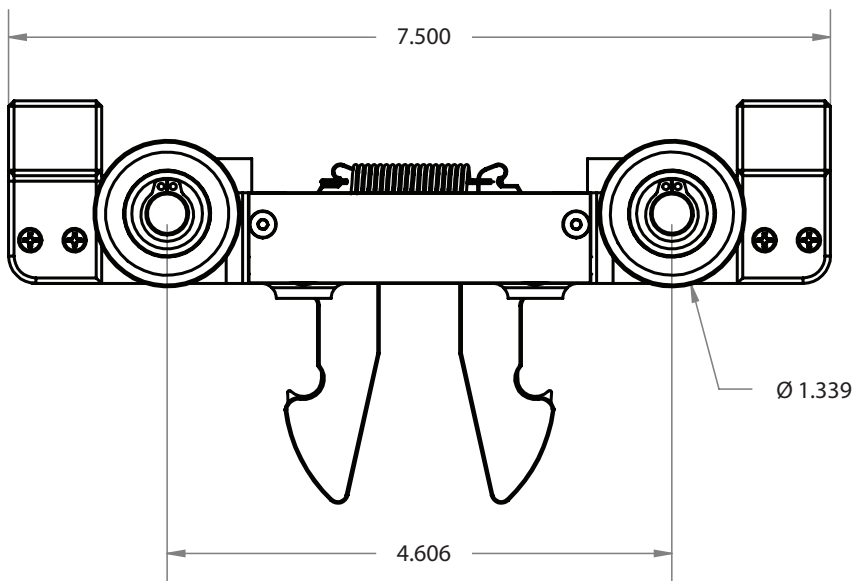
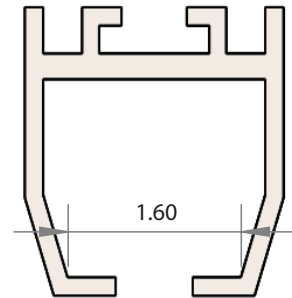
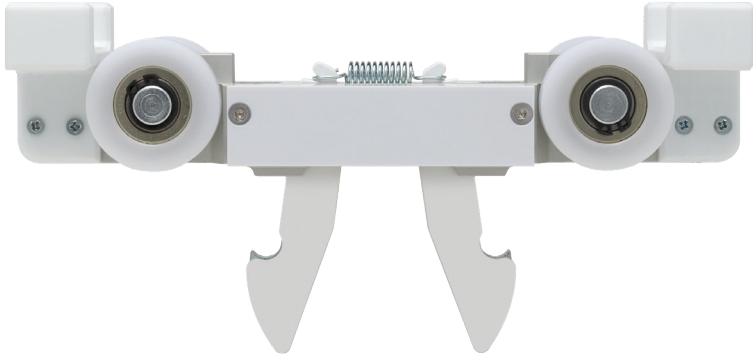

\*Dimensions are shown in inches



# Amico Competitor Trolleys

## GULDMANN (GH2) TROLLEY: GO-LIFT-QR-TRLY-GH2-UNIV-ASSY

700lbs Capacity Guldman (GH2) Trolley. Quick Connect, in-rail charge through strips.

### Compatible With:

- Straight Track
- Curved Track
- Gantry
- Gate

### Not Compatible With:

- Curtain Jumping

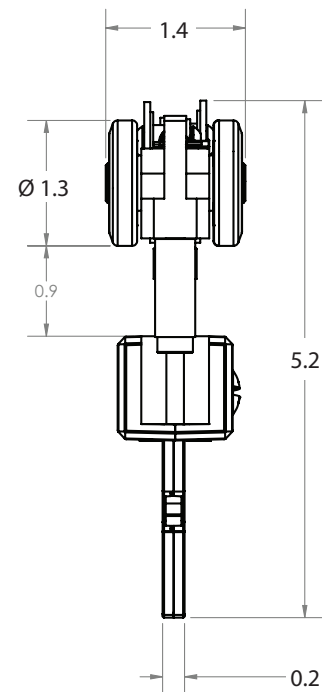
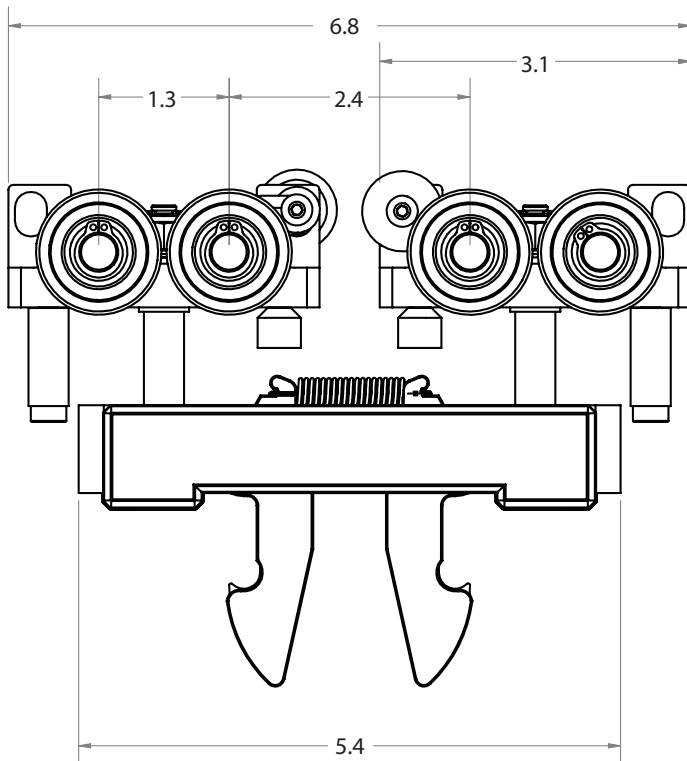
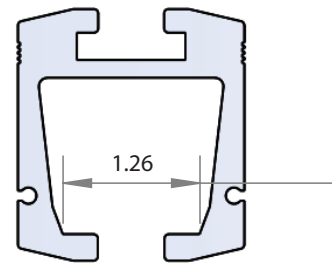
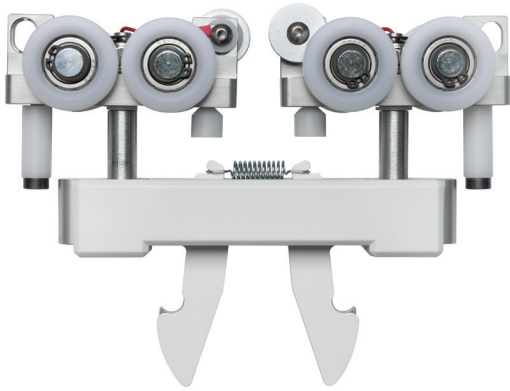

\*Dimensions are shown in inches

# Amico Competitor Trolleys

## GULDMANN (GH3) TROLLEY: GO-LIFT-QR-TRLY-GM-ASSY

700lbs Capacity Guldman Trolley (GH3). Quick Connect, in-rail charge through strips.

### Compatible With:

- Straight Track
- Gantry

### Not Compatible With:

- Curtain Jumping
- Curved Track

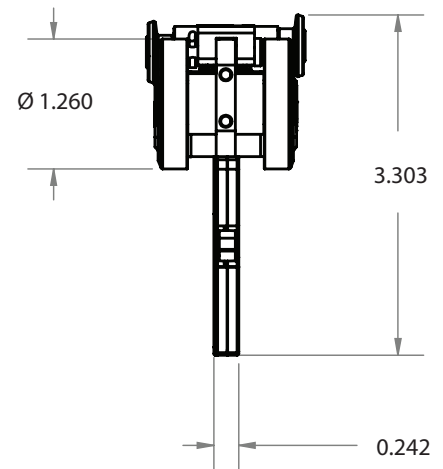
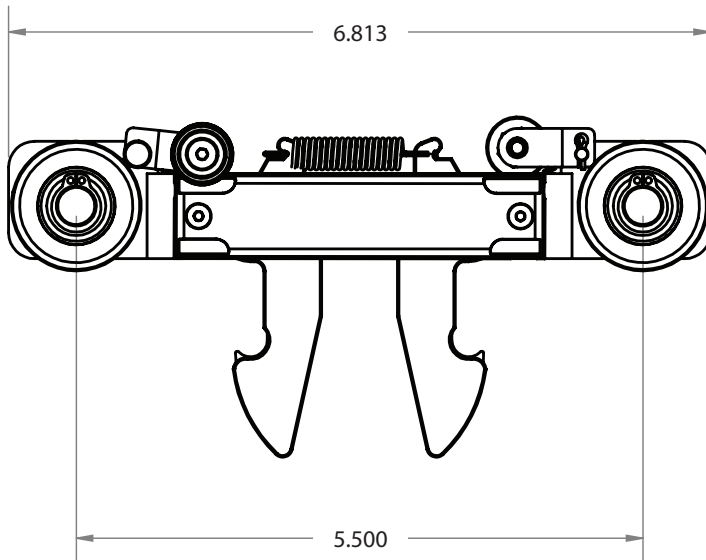
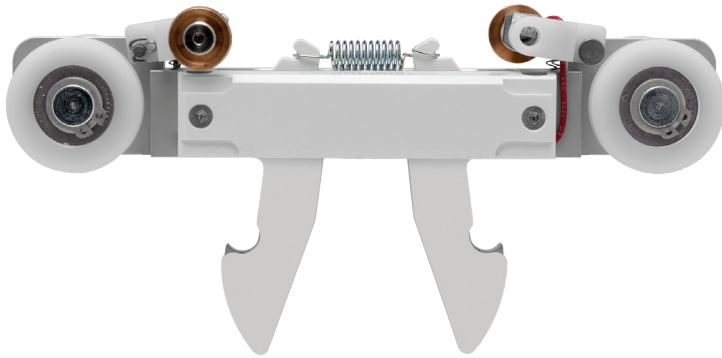

\*Dimensions are shown in inches

# Amico Competitor Trolleys

## GULDMANN (GH3) TROLLEY: PLP-TRL-GH3-S-TRK-FT-ASSY

700lbs Capacity Guldman GH3 S-Track Trolley. Fixed, in-rail charge through strips.

### Compatible With:

- Straight Track
- Curved Track
- Gantry
- Combi-Lock Gate

### Not Compatible With:

- Curtain Jumping

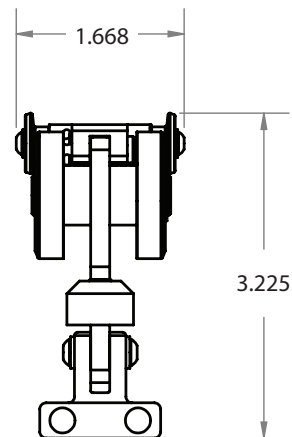
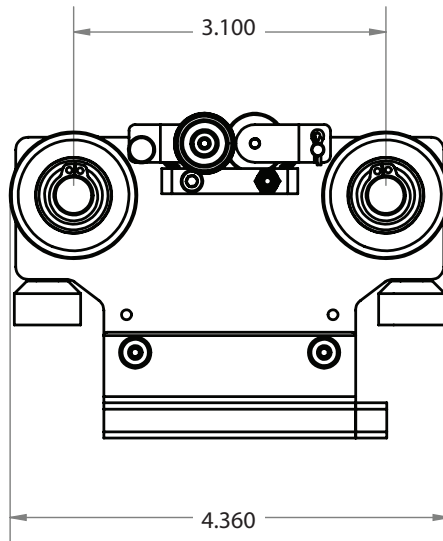
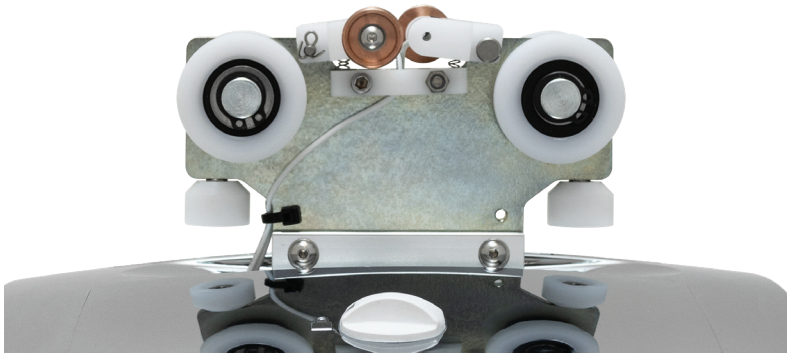

\*Dimensions are shown in inches

# Amico Competitor Trolleys

## JOERNS TROLLEY: GO-LIFT-QR-TRLY-JRNS-C-ASSY

700lbs Capacity Joerns Trolley. Quick Connect, in-rail charge through strips.

### Compatible With:

- Straight Track
- Curved Track
- Gantry

### Not Compatible With:

- Curtain Jumping

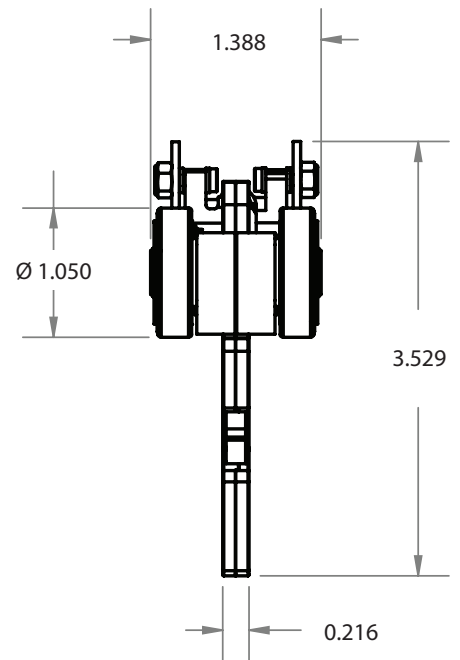
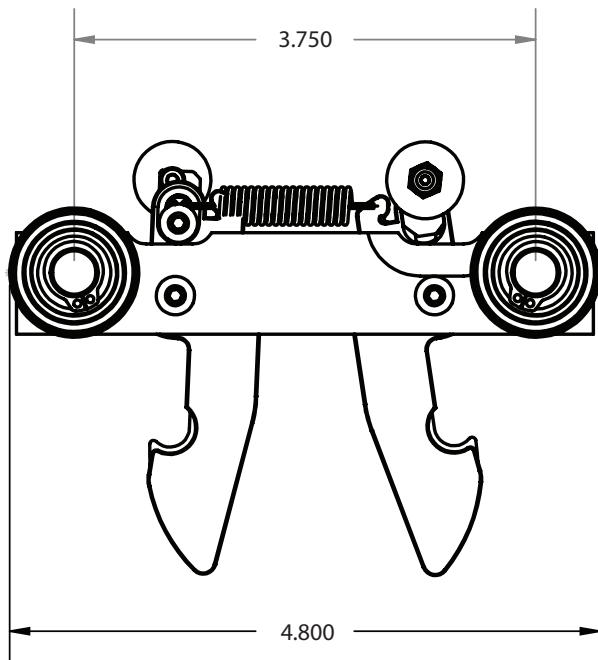
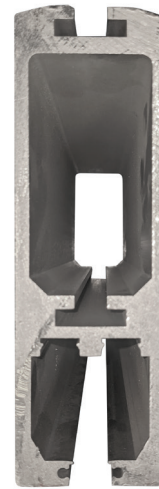
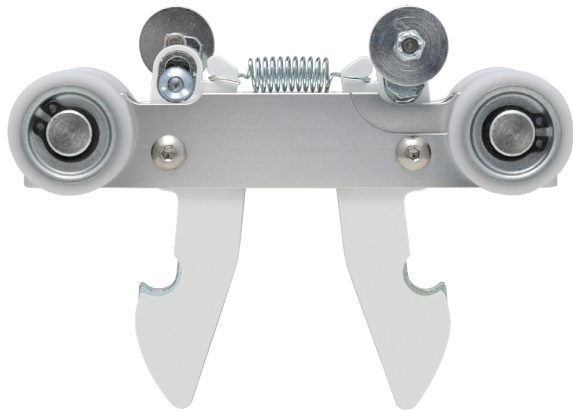

\*Dimensions are shown in inches

# Amico Competitor Trolleys

## HANDICARE TROLLEY: GO-LIFT-QR-TRLY-HCR-ASSY

700lbs Capacity Handicare Trolley. Quick Connect, in-rail charge through strips.

### Compatible With:

- Straight Track
- Curved Track
- Gantry

### Not Compatible With:

- Curtain Jumping

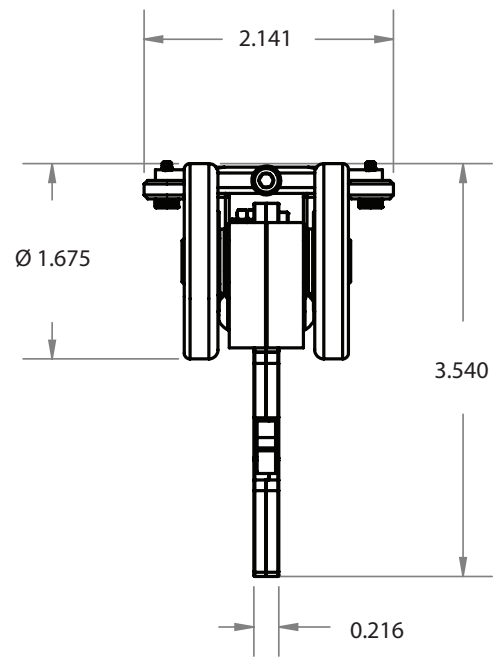
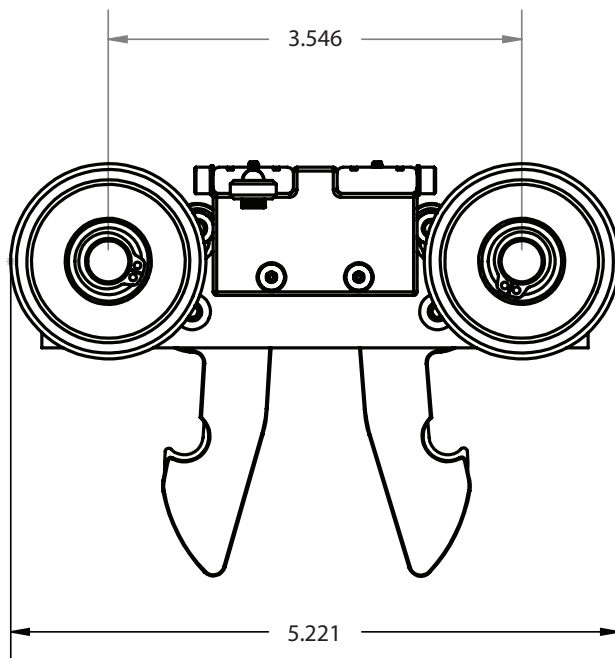
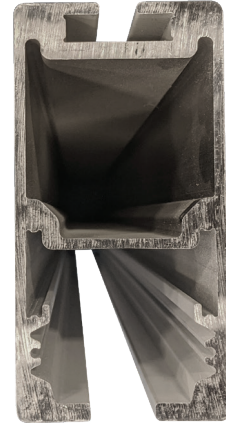
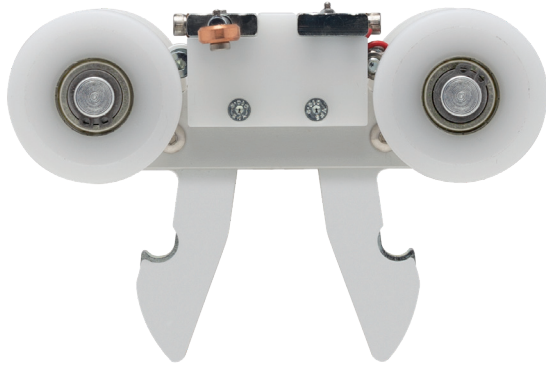

\*Dimensions are shown in inches

# Amico Competitor Trolleys

## INNOVA TROLLEY: GO-LIFT-QR-TRLY-INVA-ASSY

700lbs Capacity Innova Trolley. Quick Connect, handset charge.

### Compatible With:

- Straight Track
- Gantry

### Not Compatible With:

- Curtain Jumping
- Curved Track

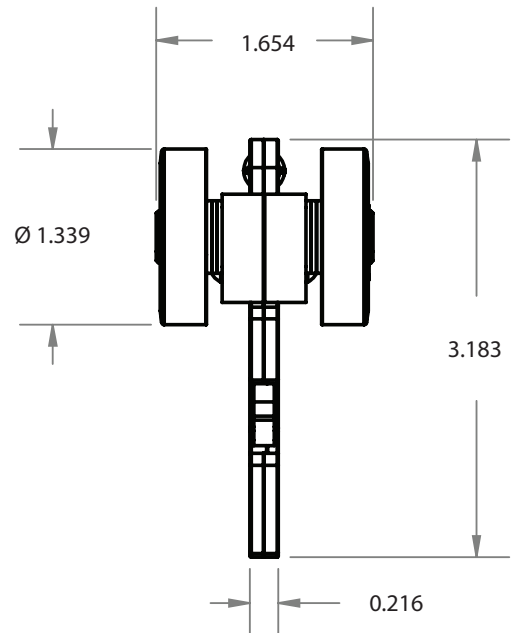
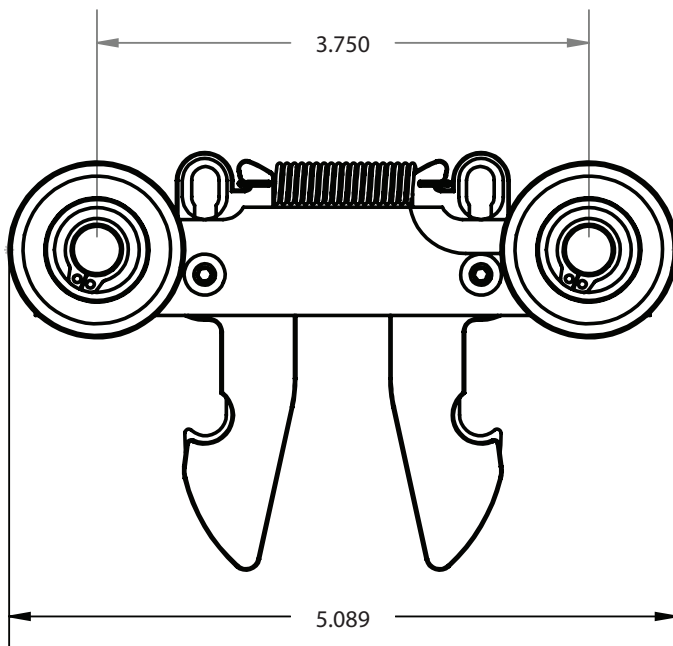
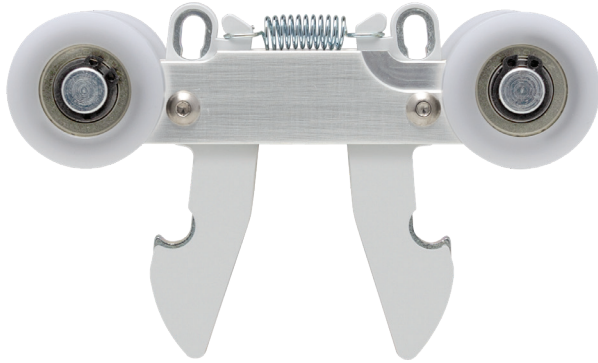

\*Dimensions are shown in inches

# Amico Competitor Trolleys

## JOERNS TROLLEY: GO-LIFT-1000-TRLY-JRNS

1000lbs Capacity Joerns Trolley. Quick Connect, in-rail charge through strips.

### Compatible With:

- Straight Track
- Curved Track
- Gantry

### Not Compatible With:

- Curtain Jumping

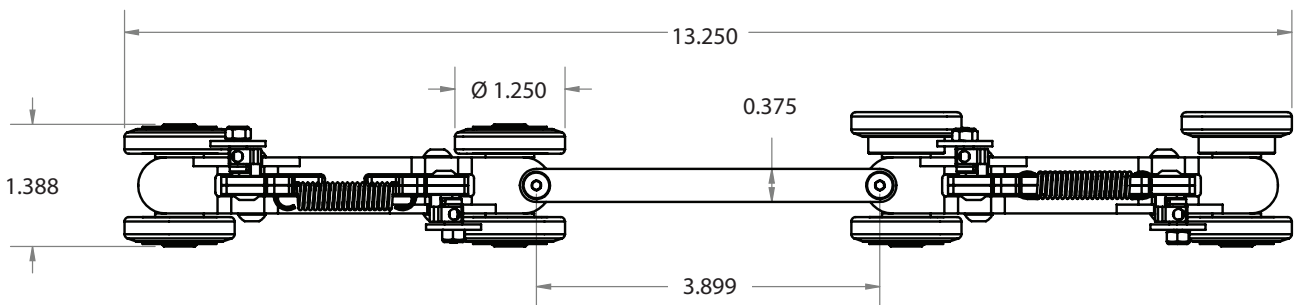
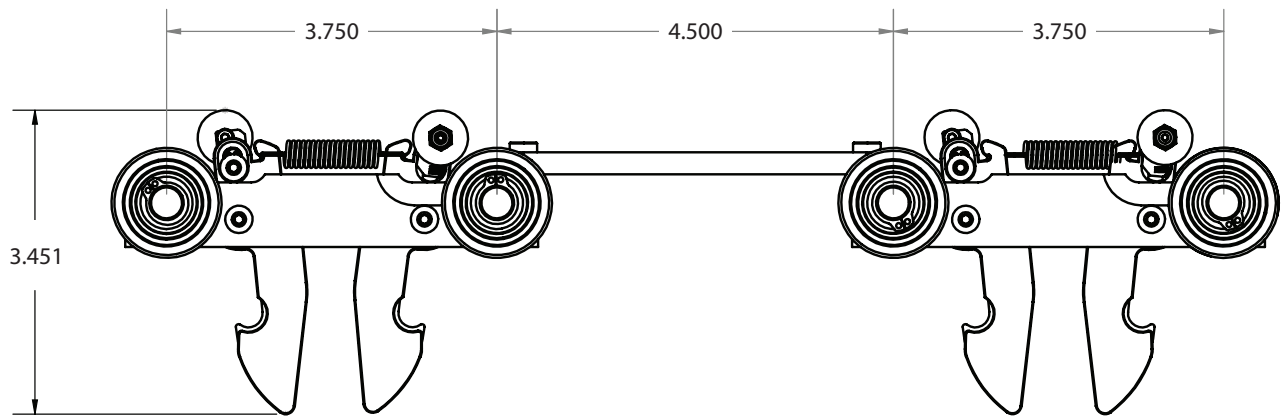
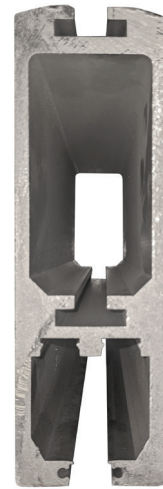

\*Dimensions are shown in inches

# Amico Competitor Trolleys

## LIKO TROLLEY: GO-LIFT-QR-TRLY-LIKO-ASSY

700lbs Capacity Liko Trolley. Quick Connect, in-rail end stop dock charge (includes dock plate to be mounting on existing end stop).

### Compatible With:

- Straight Track
- Curved Track
- Gantry

### Not Compatible With:

- Curtain Jumping

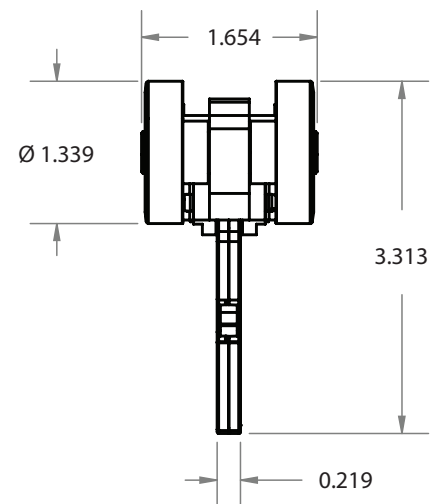
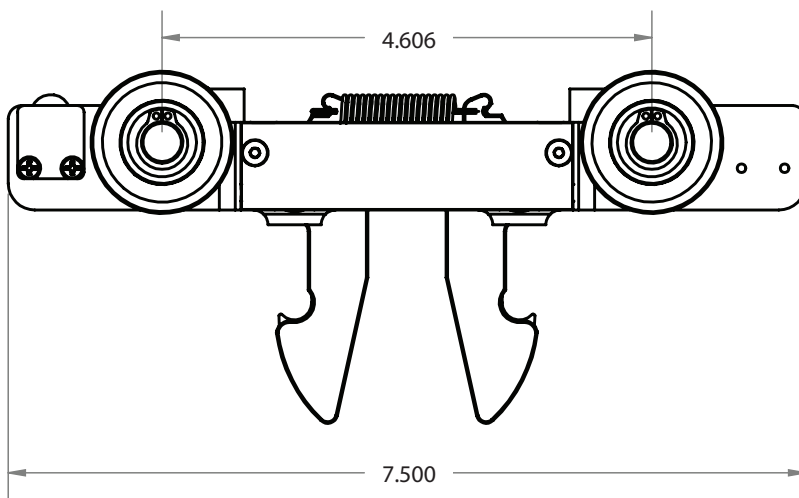
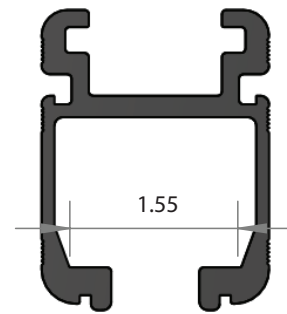
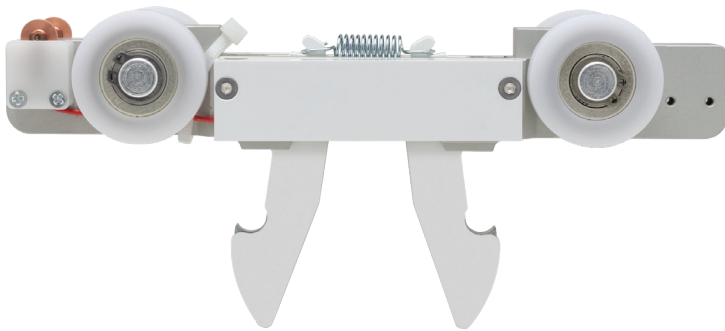

\*Dimensions are shown in inches



# Amico Competitor Trolleys

## SOLO STEP TROLLEY: GO-LIFT-QR-TRLY-SS-HSC-ASSY

700lbs Capacity Solo Step Trolley. Quick Connect, handset charge.

### Compatible With:

- Straight Track
- Gantry

### Not Compatible With:

- Curtain Jumping
- Curved Track

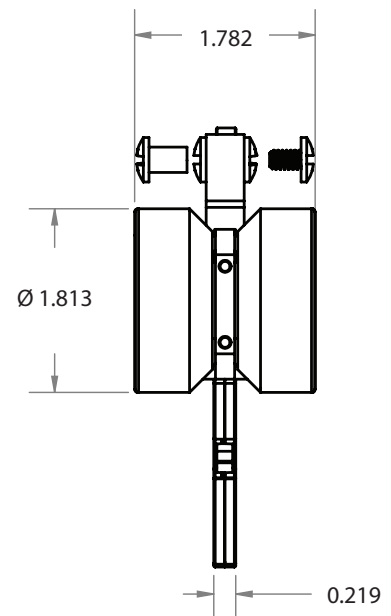
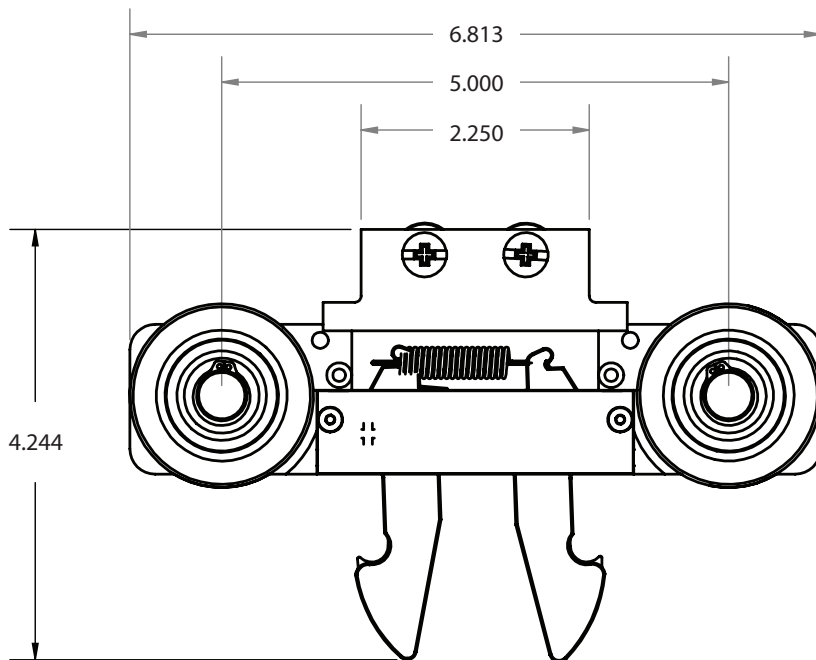
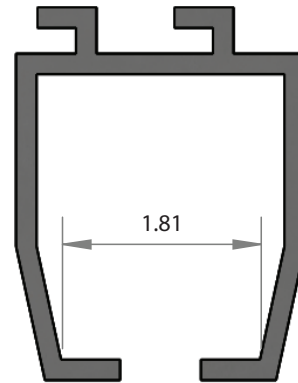
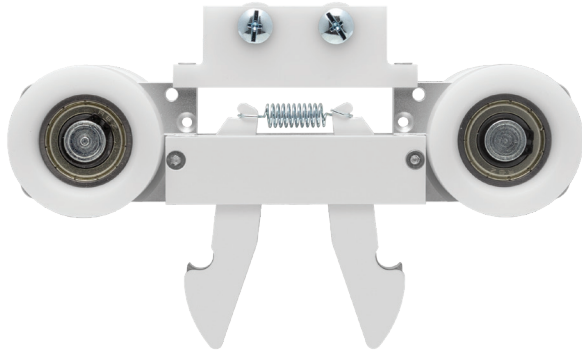

\*Dimensions are shown in inches

# Amico Competitor Trolleys

## STEISS TROLLEY: GO-LIFT-QR-TRLY-STEISS-ASSY

700lbs Capacity Steiss Trolley. Quick Connect, in-rail charge through strips.

### Compatible With:

- Straight Track
- Curved Track
- Gantry

### Not Compatible With:

- Curtain Jumping

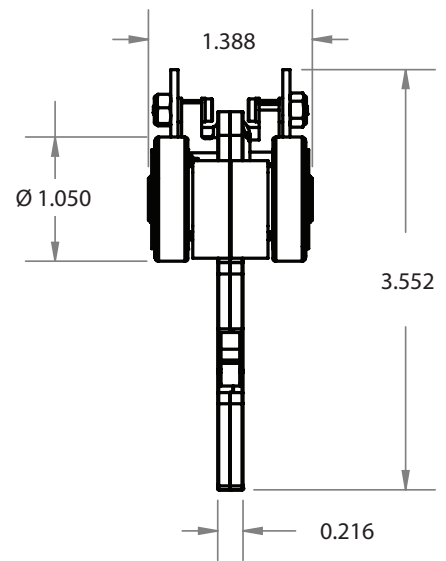
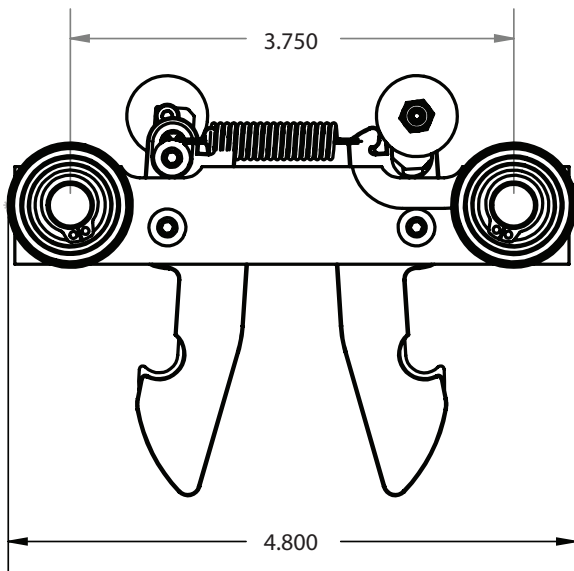
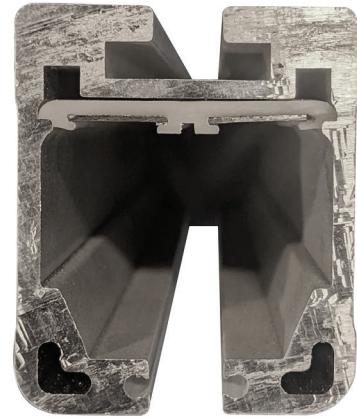
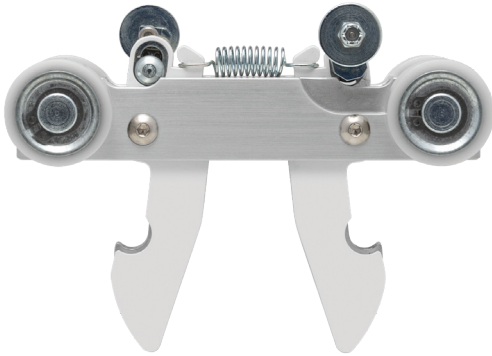

\*Dimensions are shown in inches

# Amico Competitor Trolleys

## TOLLOS TROLLEY: GO-LIFT-QR-TOLLOS-CC

700lbs Capacity Tollos Trolley. Quick Connect, in-rail charge through strips.

### Compatible With:

- Straight Track
- Gantry

### Not Compatible With:

- Curtain Jumping
- Curved Track

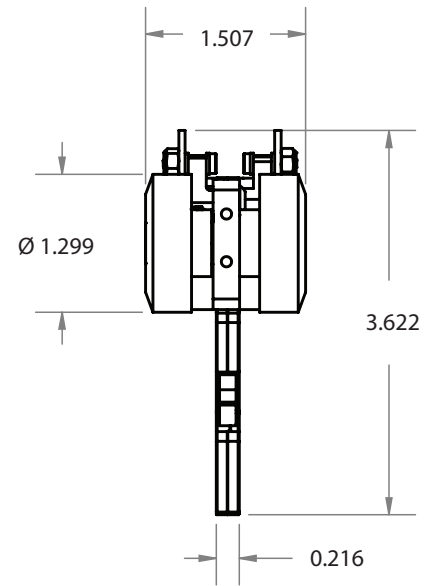
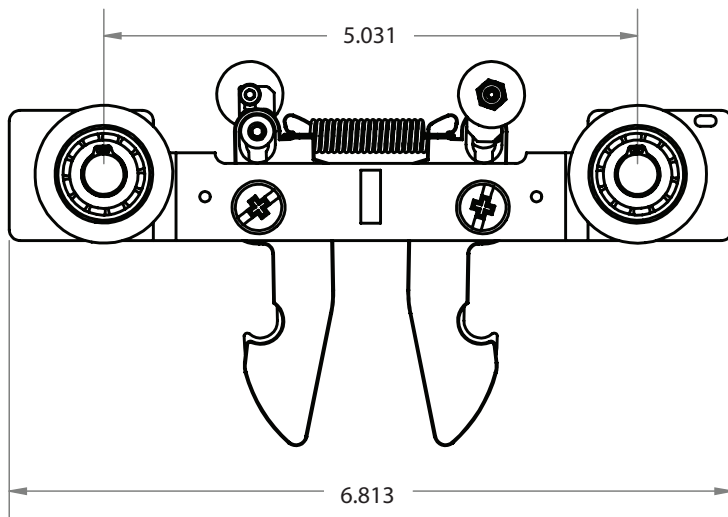
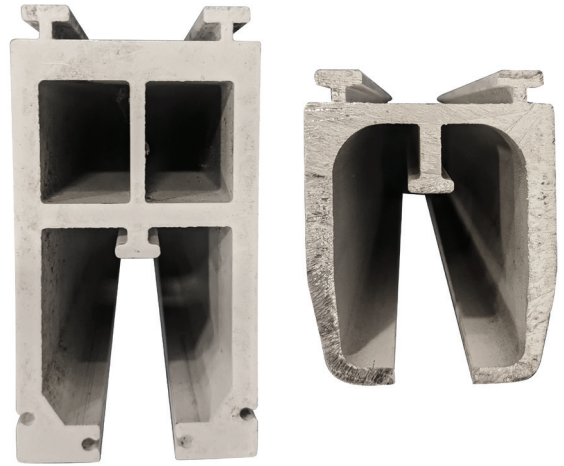
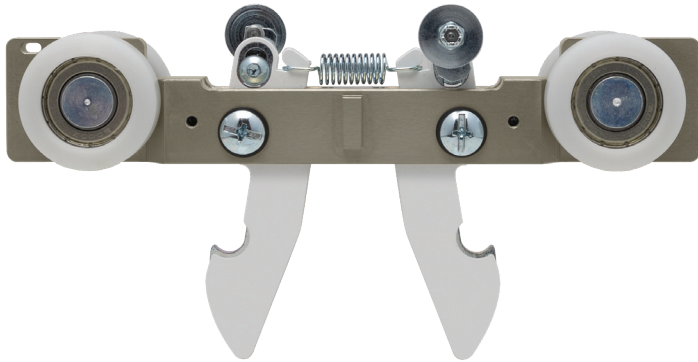

\*Dimensions are shown in inches

# Amico Competitor Trolleys

## TOLLOS TROLLEY: GO-LIFT-QR-TOLLOS-EC

700lbs Capacity Tollos Trolley. Quick Connect, in-rail end stop dock charge.

### Compatible With:

- Straight Track
- Curved Track
- Gantry

### Not Compatible With:

- Curtain Jumping

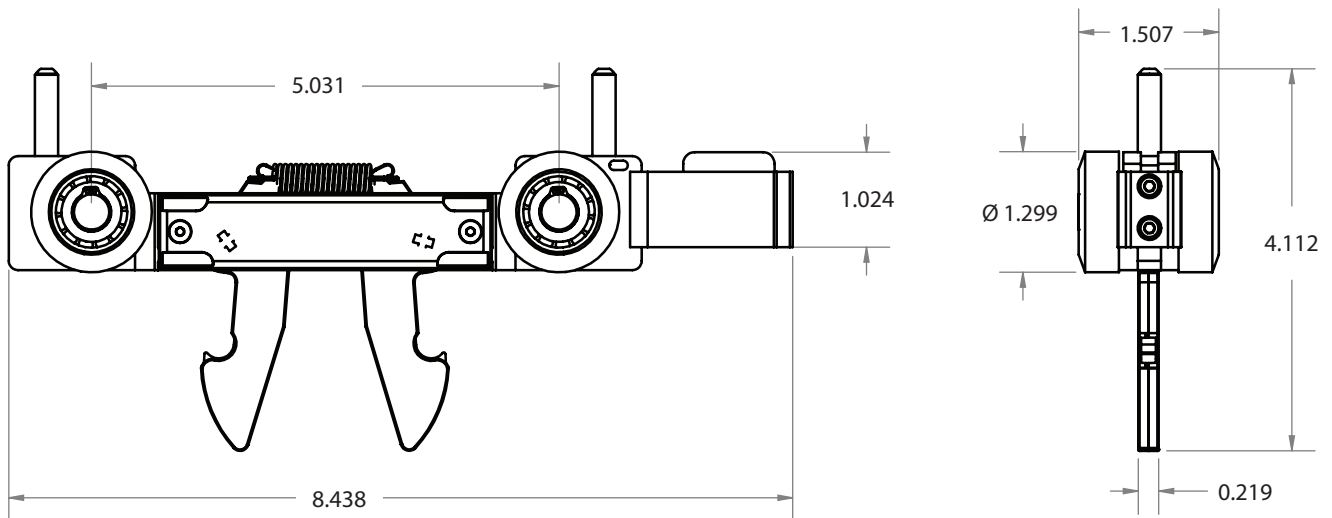
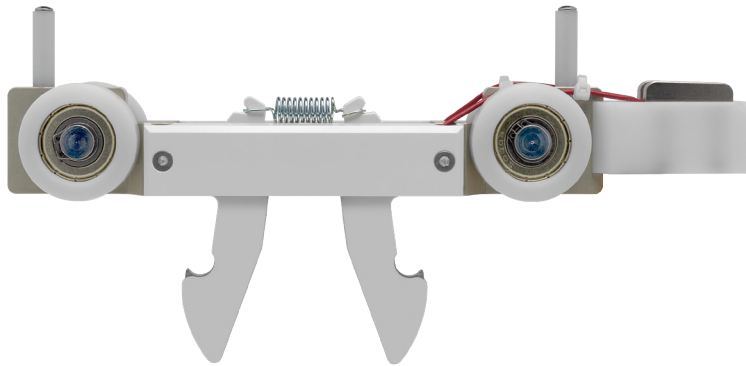

\*Dimensions are shown in inches

# Amico Competitor Trolleys

## TOLLOS TROLLEY: GO-LIFT-QR-TOLLOS-EC-H

700lbs Capacity Tollos Trolley. Quick Connect, in-rail end stop dock charge (end stop charger sits slightly higher).

### Compatible With:

- Straight Track
- Curved Track
- Gantry

### Not Compatible With:

- Curtain Jumping

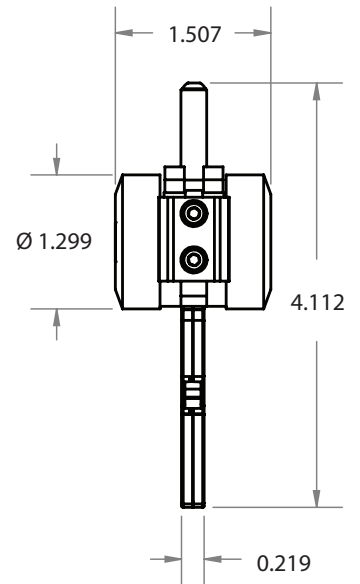
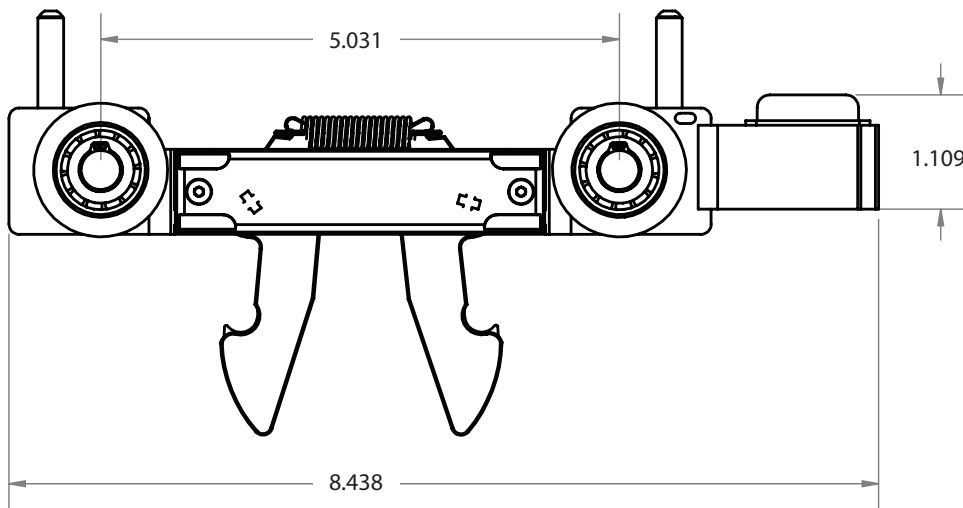
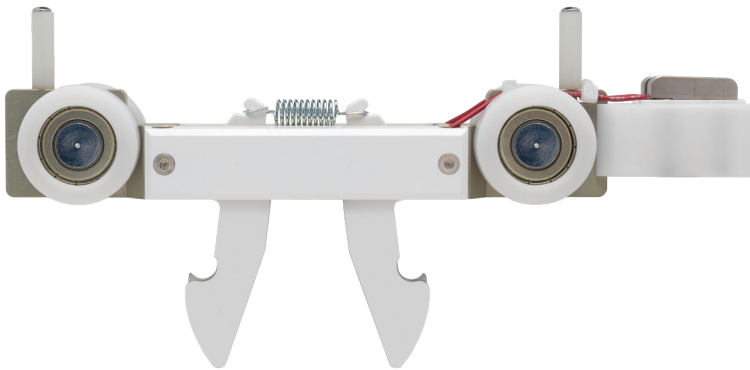

\*Dimensions are shown in inches

# Amico Competitor Trolleys

## TOLLOS TROLLEY: GO-LIFT-1000-QR-TRLY-TOLLOS-EC

1000lbs Capacity Tollos Trolley. Quick Connect, In-rail end stop dock charge.

### Compatible With:

- Straight Track
- Curved Track
- Gantry

### Not Compatible With:

- Curtain Jumping

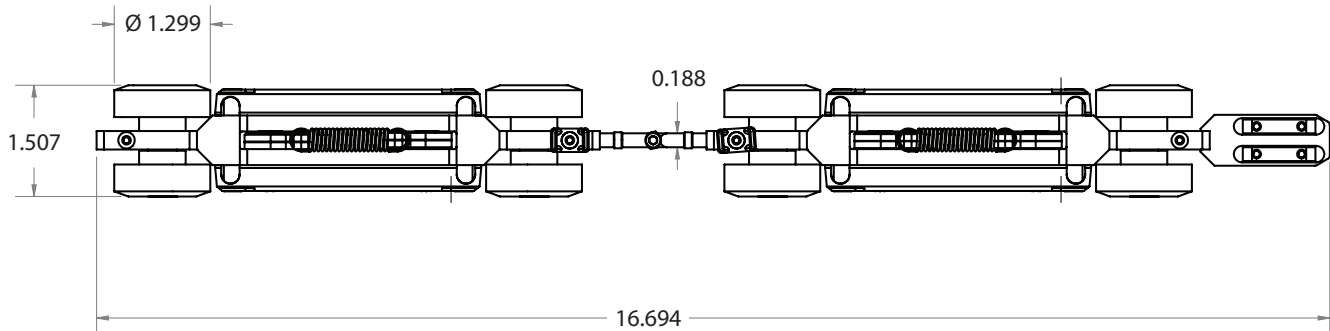
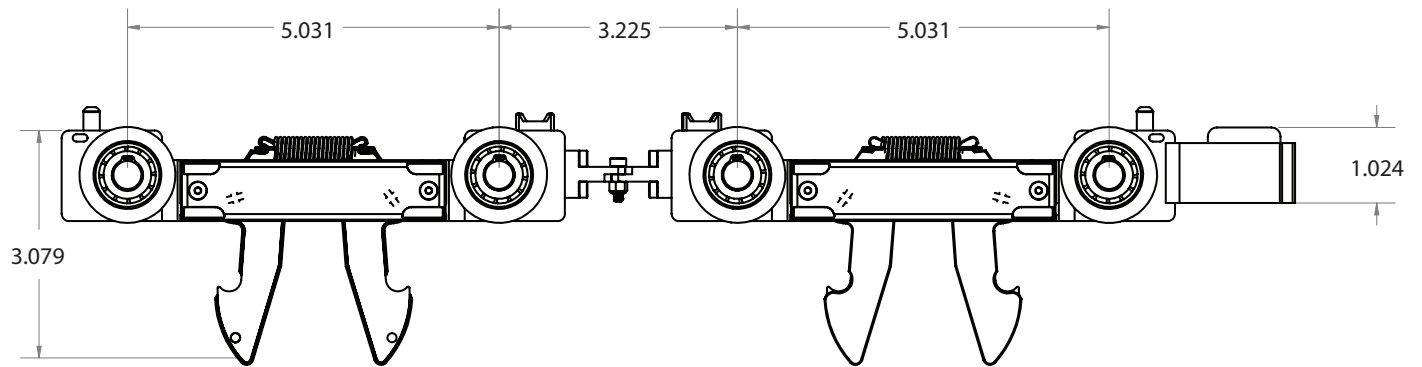
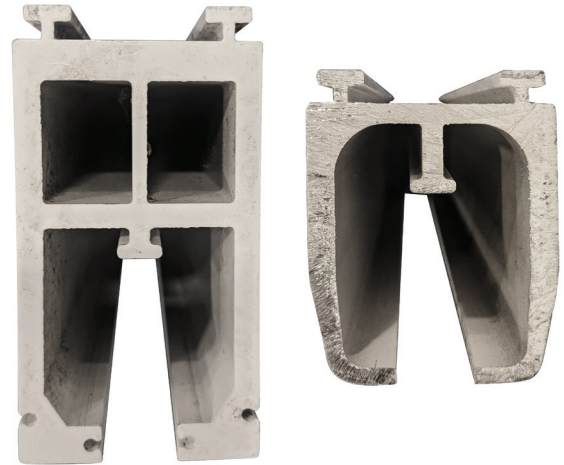
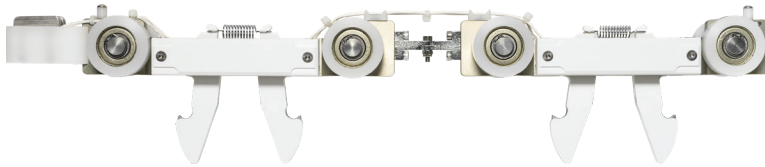

\*Dimensions are shown in inches

# Amico Competitor Trolleys

## PRISM/WAVERLEY GLEN TROLLEY: GO-LIFT-QR-TRLY-WGCC-ASSY

700lbs Capacity Prism/Waverley Glen Trolley. Quick Connect, in-rail charge through strips.

### Compatible With:

- Straight Track
- Curved Track
- Gantry

### Not Compatible With:

- Curtain Jumping

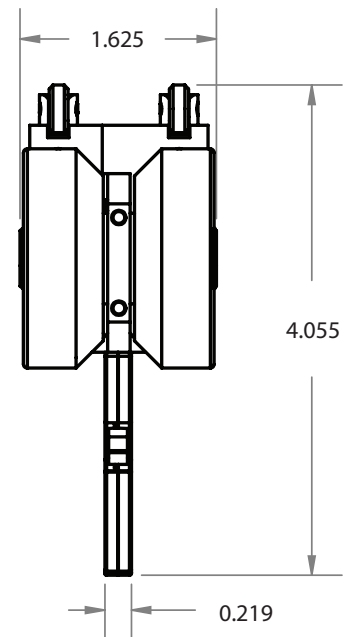
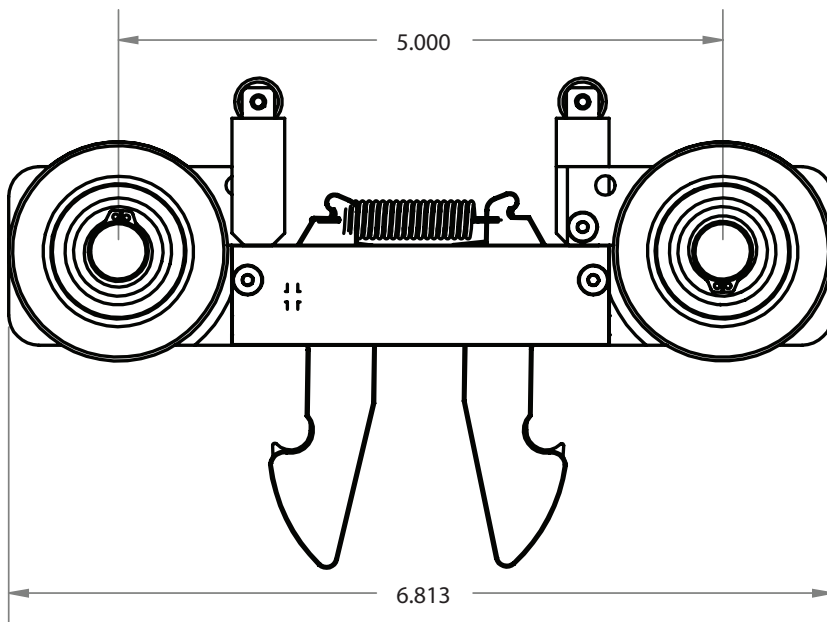
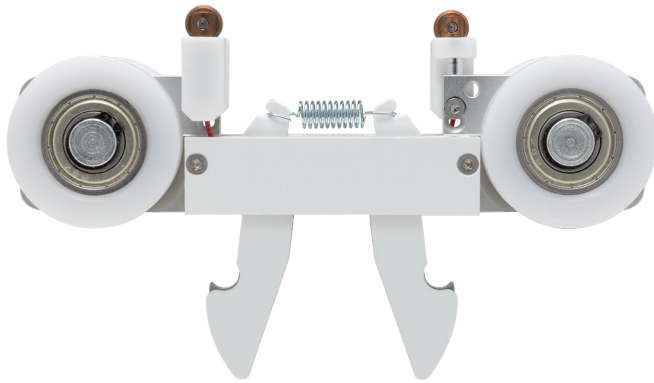

\*Dimensions are shown in inches

# Amico Competitor Trolleys

## PRISM/WAVERLEY GLEN TROLLEY: GO-LIFT-QR-TRLY-WGCC-ST-ASSY

700lbs Capacity Prism/Waverly Glen Super Track Trolley. Quick Connect, in-rail charge through strips.

### Compatible With:

- Straight Track
- Curved Track
- Gantry

### Not Compatible With:

- Curtain Jumping

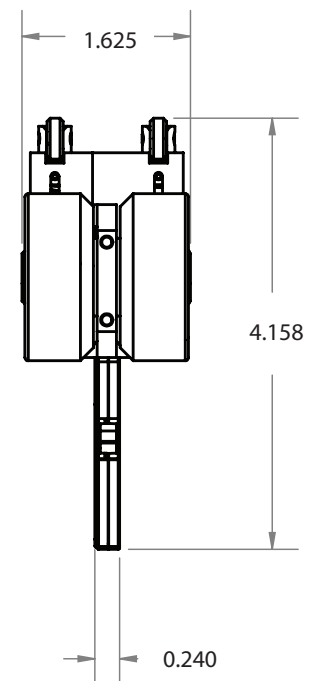
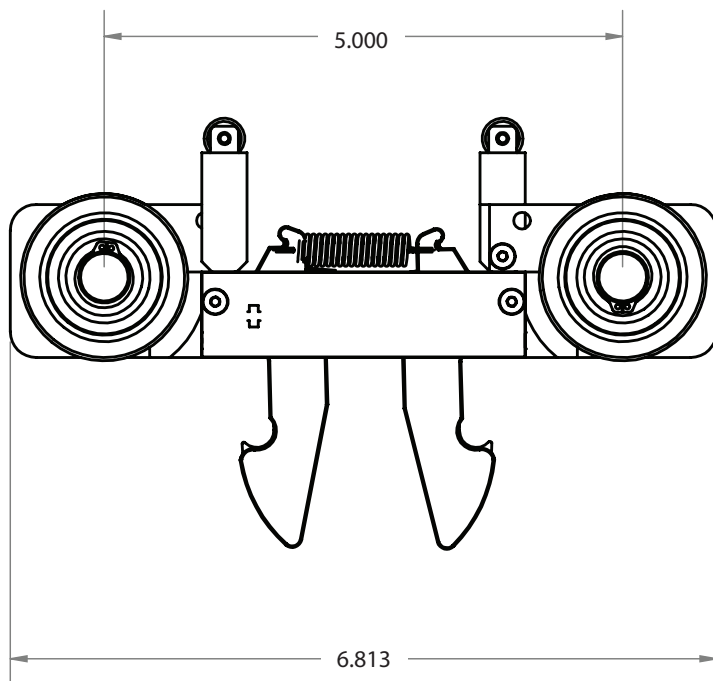
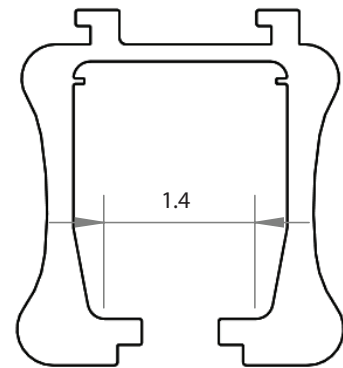
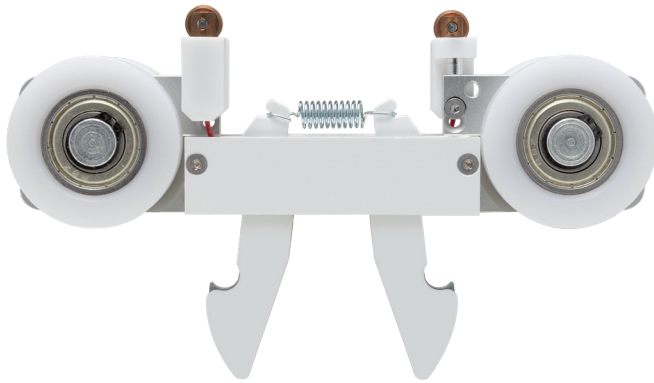

\*Dimensions are shown in inches



# Amico Competitor Trolleys

## PRISM/WAVERLEY GLEN TROLLEY: GO-LIFT-QR-TRLY-WGEC-ASSY

700lbs Capacity Prism/Waverly Glen Trolley. Quick Connect, in-rail end stop dock charge.

### Compatible With:

- Straight Track
- Curved Track
- Gantry

### Not Compatible With:

- Curtain Jumping

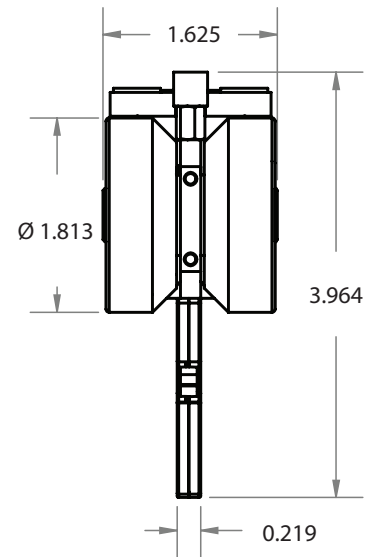
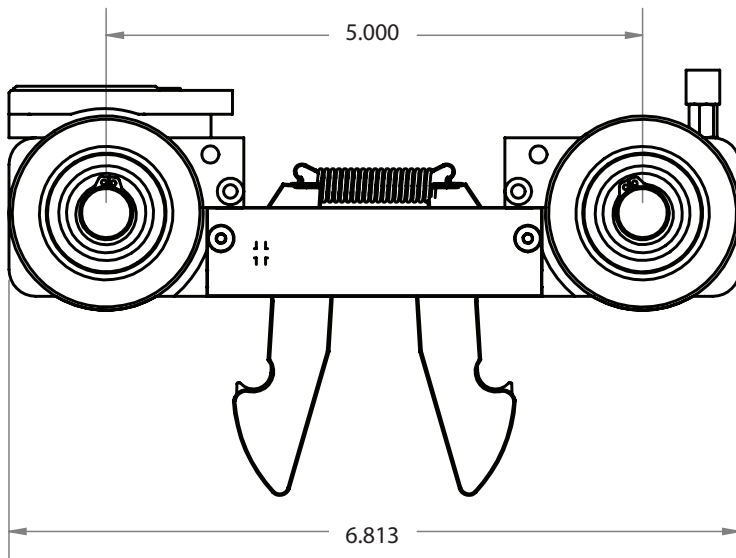
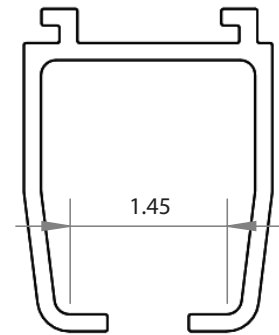
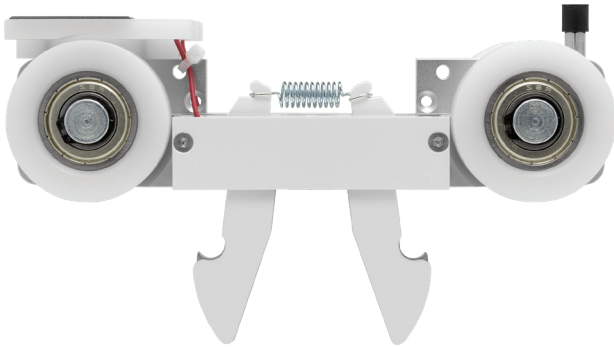

\*Dimensions are shown in inches

# Amico Competitor Trolleys

## PRISM/WAVERLEY GLEN TROLLEY: GO-LIFT-QR-TRLY-WGEC-ST-ASSY

700lbs Capacity Prism/Waverly Glen Super Track Trolley. Quick Connect, in-rail end stop dock charge.

### Compatible With:

- Straight Track
- Gantry
- Curved Track

### Not Compatible With:

- Curtain Jumping

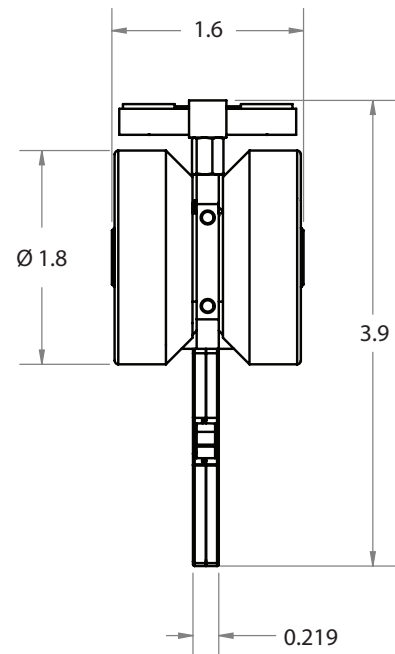
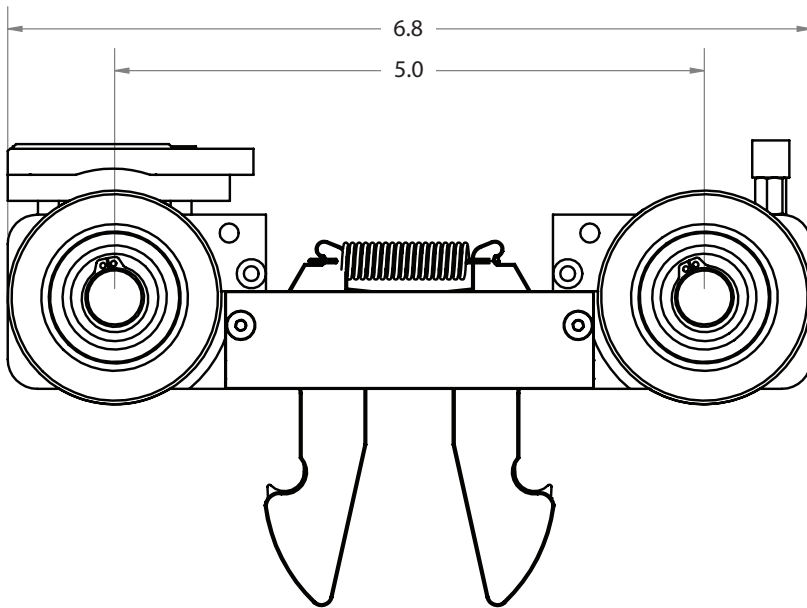
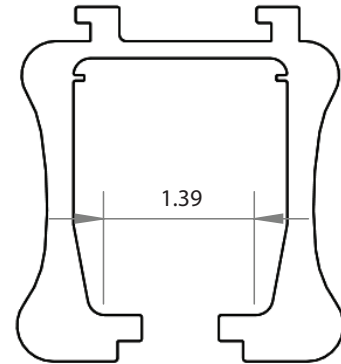
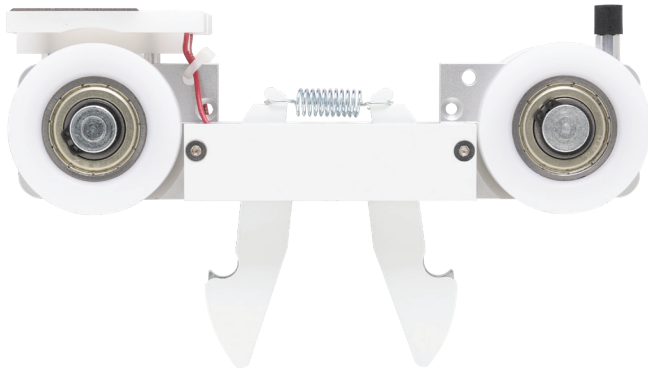

\*Dimensions are shown in inches

# Amico Competitor Trolleys

## PRISM/WAVERLEY GLEN TROLLEY: GO-LIFT-1000-WGN-CC-TRLY

1000lbs Capacity Prism Trolley. Quick Connect, in-rail charge through strips.

### Compatible With:

- Straight Track
- Curved Track
- Gantry

### Not Compatible With:

- Curtain Jumping

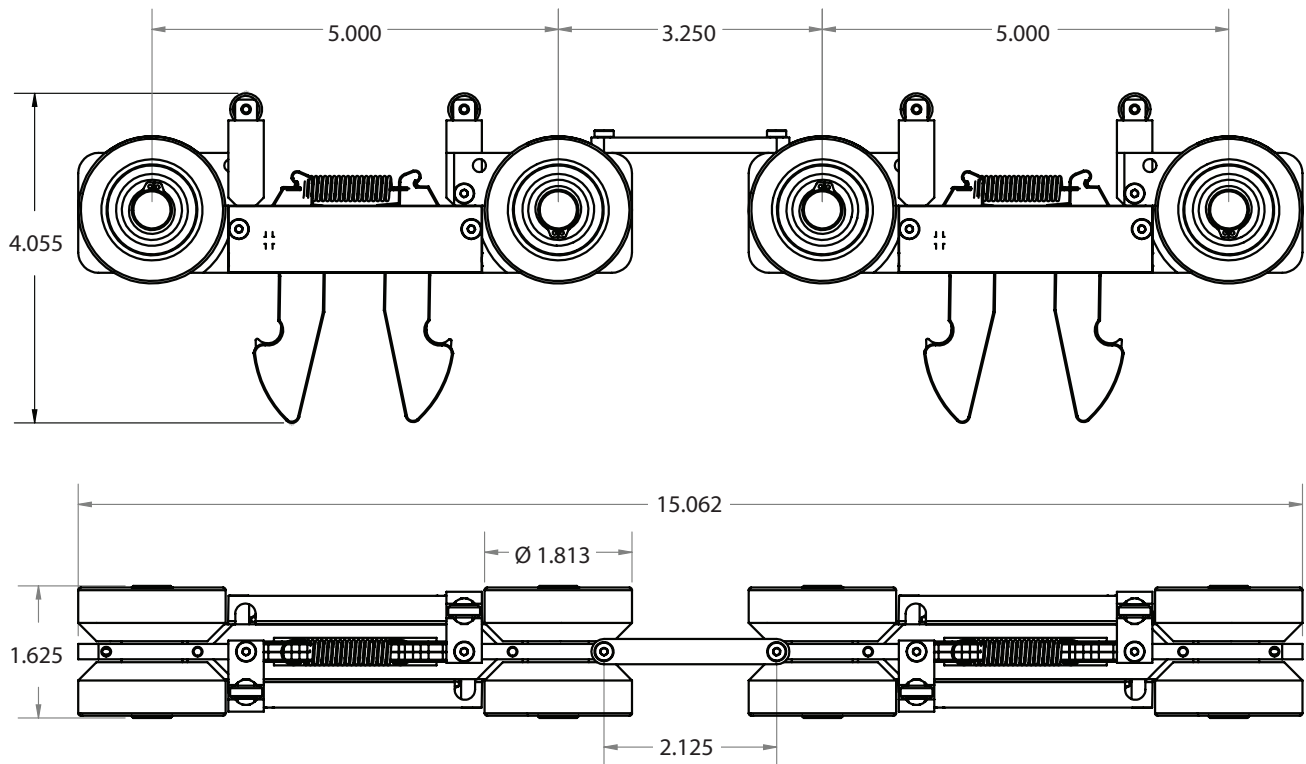

\*Dimensions are shown in inches

# Amico Competitor Trolleys

## PRISM/WAVERLEY GLEN TROLLEY: GO-LIFT-1000-WGN-EC-TRLY

1000lbs Capacity Prism Trolley. Quick Connect, in-rail end stop dock charge.

### Compatible With:

- Straight Track
- Curved Track
- Gantry

### Not Compatible With:

- Curtain Jumping

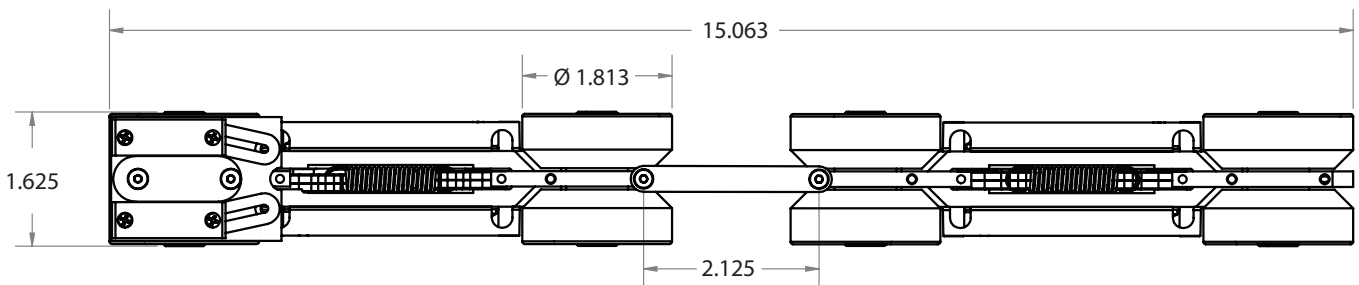
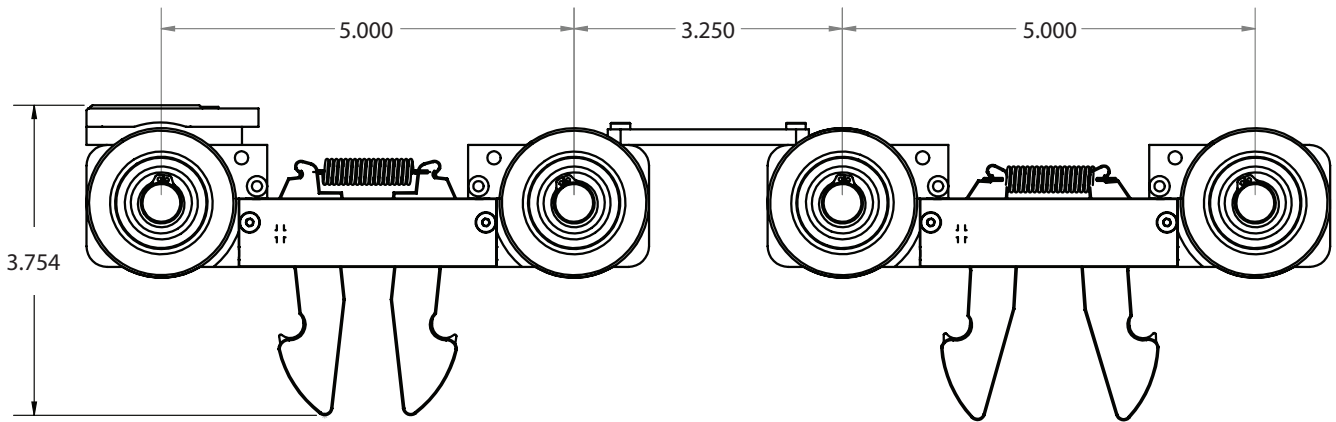
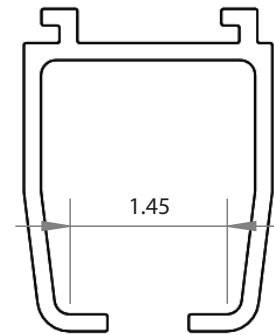

\*Dimensions are shown in inches

EC REP AJW Technology Consulting GmbH  
Breite Str. 3, 40213 Düsseldorf, Germany

Amico Mobility Solutions Corporation | [www.amico.com](http://www.amico.com)  
122-B East Beaver Creek Road, Richmond Hill, ON L4B 1G6, Canada | 600 Prime Place, Hauppauge, NY 11788, USA  
Toll Free Telephone: 1.877.462.6426 | Toll Free Fax: 1.866.440.4986 | Telephone: 905.764.0800 | Fax: 905.764.0862

