

Desiccant Air Treatment Dryer/Filter/Regulator System

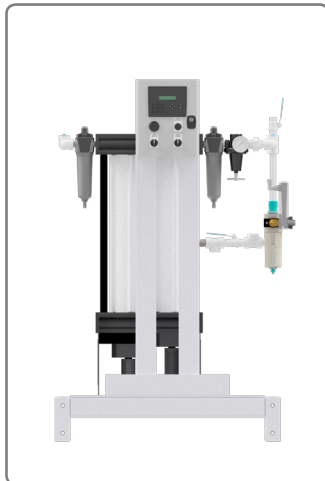

Front View

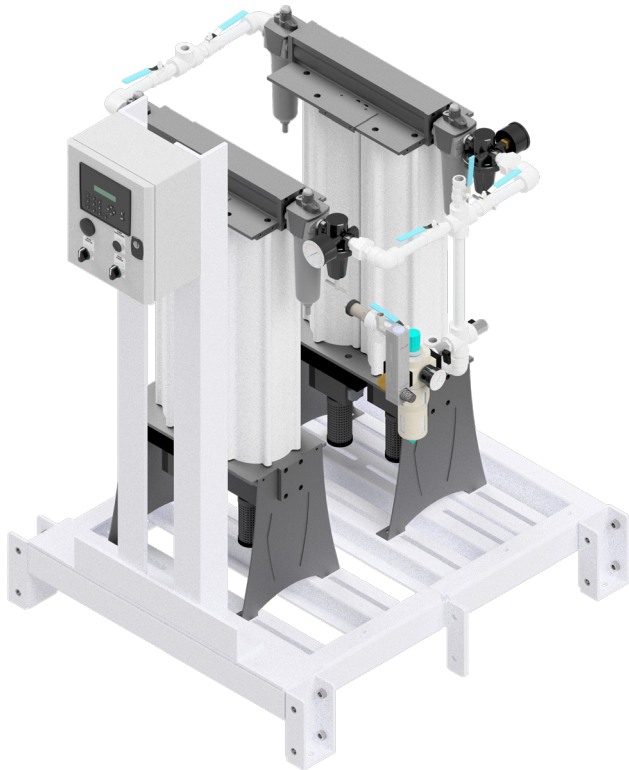
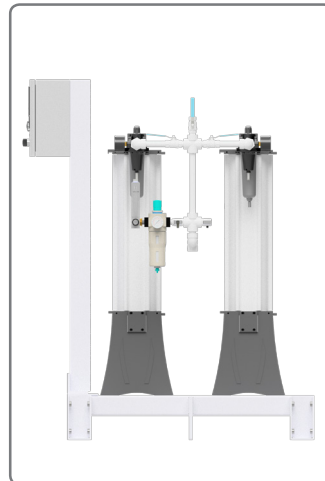

Side View

Specifications

- NFPA 99 compliant dual desiccant air dryers with an integral, demand based, purge saving control system.
- Equipped with two pre-filters, two after-filters, two pressure regulator valves, one control panel and multiple system safety valves.
- Completely pre-piped and pre-wired to single point service connections.
- There shall be two identical banks of air treatment equipment, piped in parallel and provided with valves to bypass either filter set for element replacement, maintenance and repair work while still treating medical compressed air through the other set.
- Each bank consists of three stages:
 - 1st stage: prime efficiency coalescer with filtered differential pressure gauge and electric solenoid auto drain valve.
 - 2nd stage: desiccant heatless air dryer equipped with purge control.
 - 3rd stage: prime efficiency particulate afterfilter with differential pressure gauge and manual drain.
- Control panel will provide continuous readout of CO and dew point readings at a single screen.
- Control panel is provided with dry contacts for connection to remote annunciation.
- Isolation valves for maintenance are included.
- Dew point based purge control with field adjustable settings.

Furnish and install, where shown on the drawing, a prefabricated desiccant air treatment system as manufactured by Amico Source Corporation.

The service of a factory trained representative shall be made available at job site to check installation and start up as well as train operating personnel in proper operation and maintenance procedures. A start-up form shall be completed at the time of start-up by a factory trained representative.

Amico Source Corporation | 85 Fulton Way, Richmond Hill, ON L4B 2N4, Canada | 600 Prime Place, Hauppauge, NY 11788, USA
Toll Free Tel: 1.877.462.6426 | Tel: 905.764.0800 | Fax: 905.764.0862

www.amico.com

AS-SP-DRYER-FILTER-REG 06.21.2017