

CONTACTLESS CLAW - DRY DUPLEX "SPACE SAVER" VACUUM SYSTEM (2.0 HP - 5.0 HP)

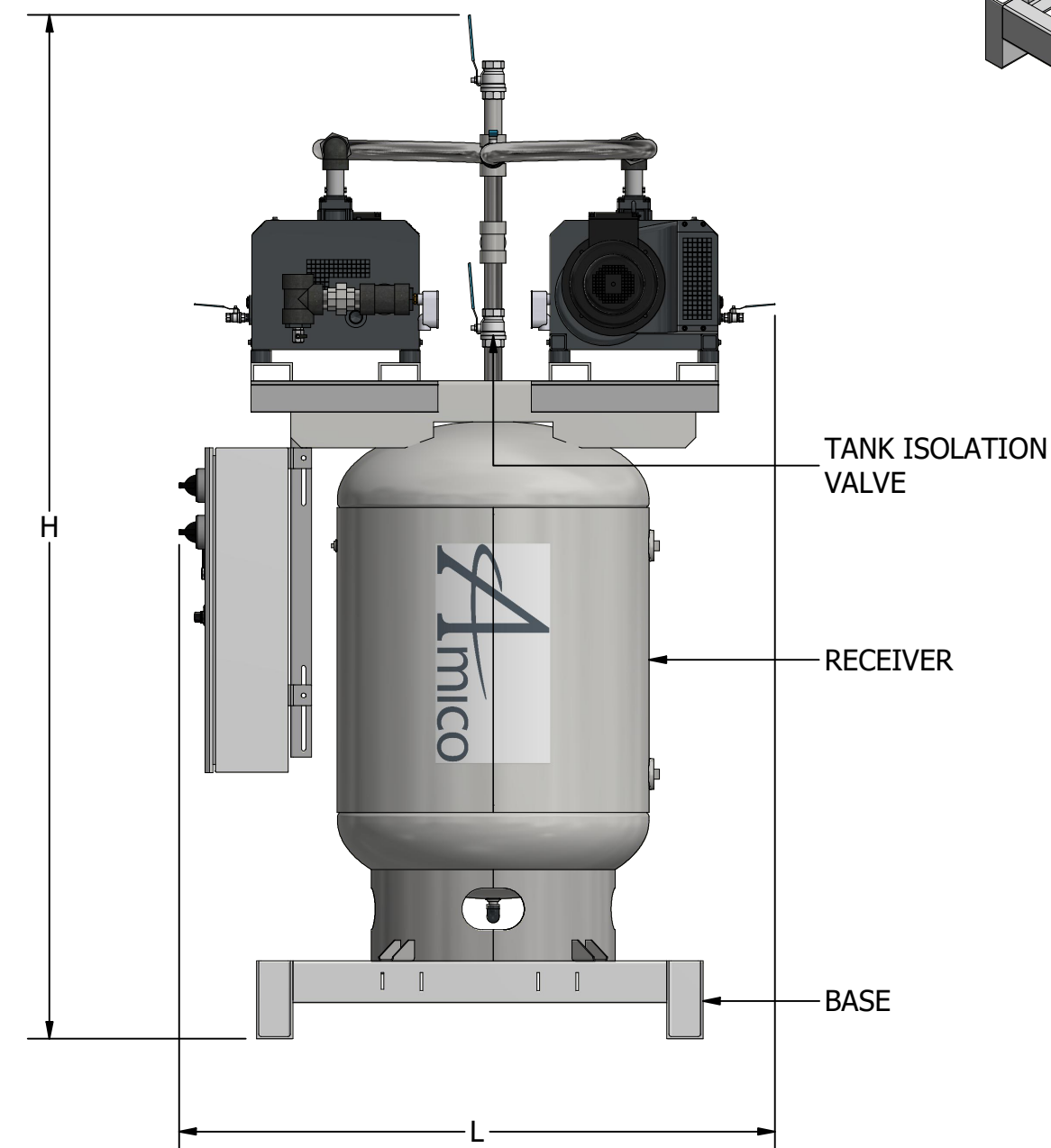
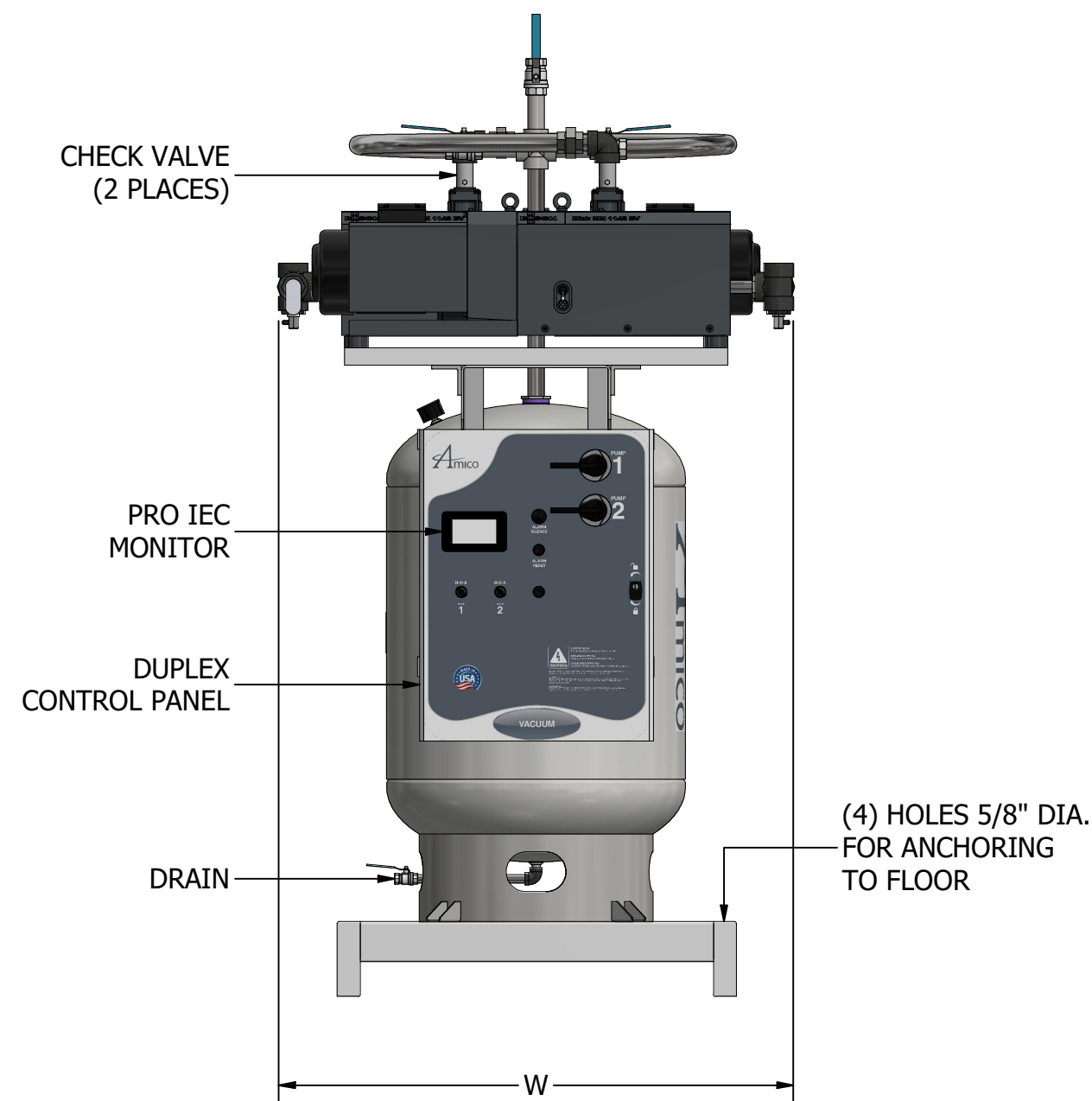
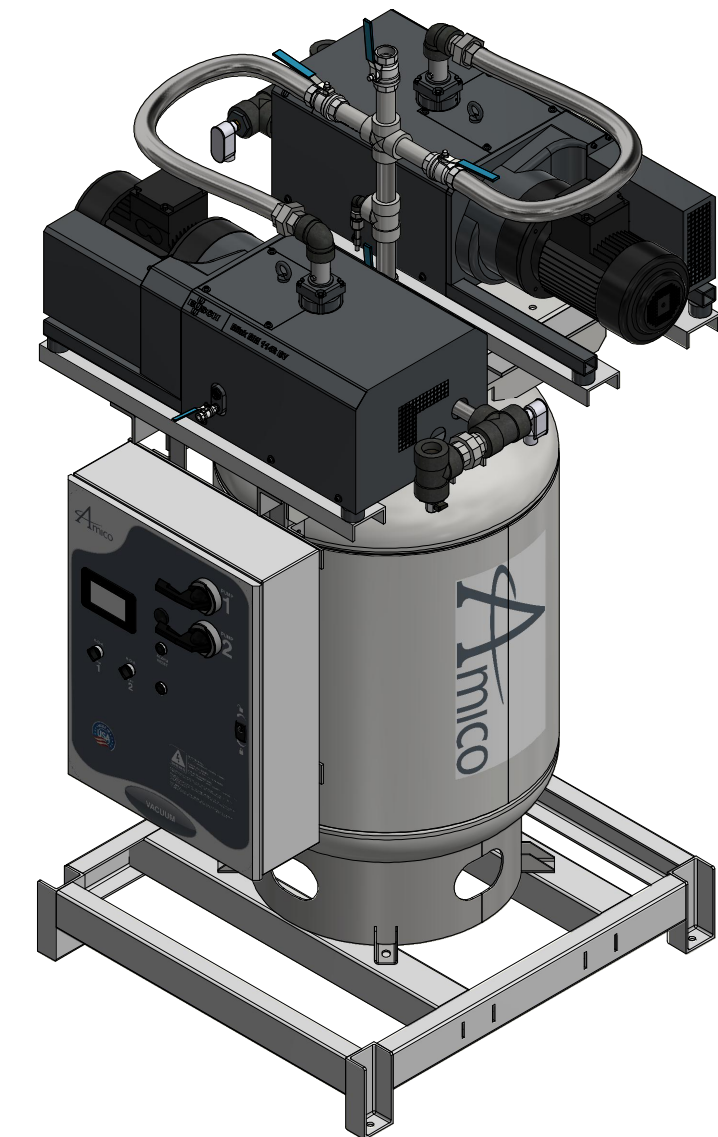
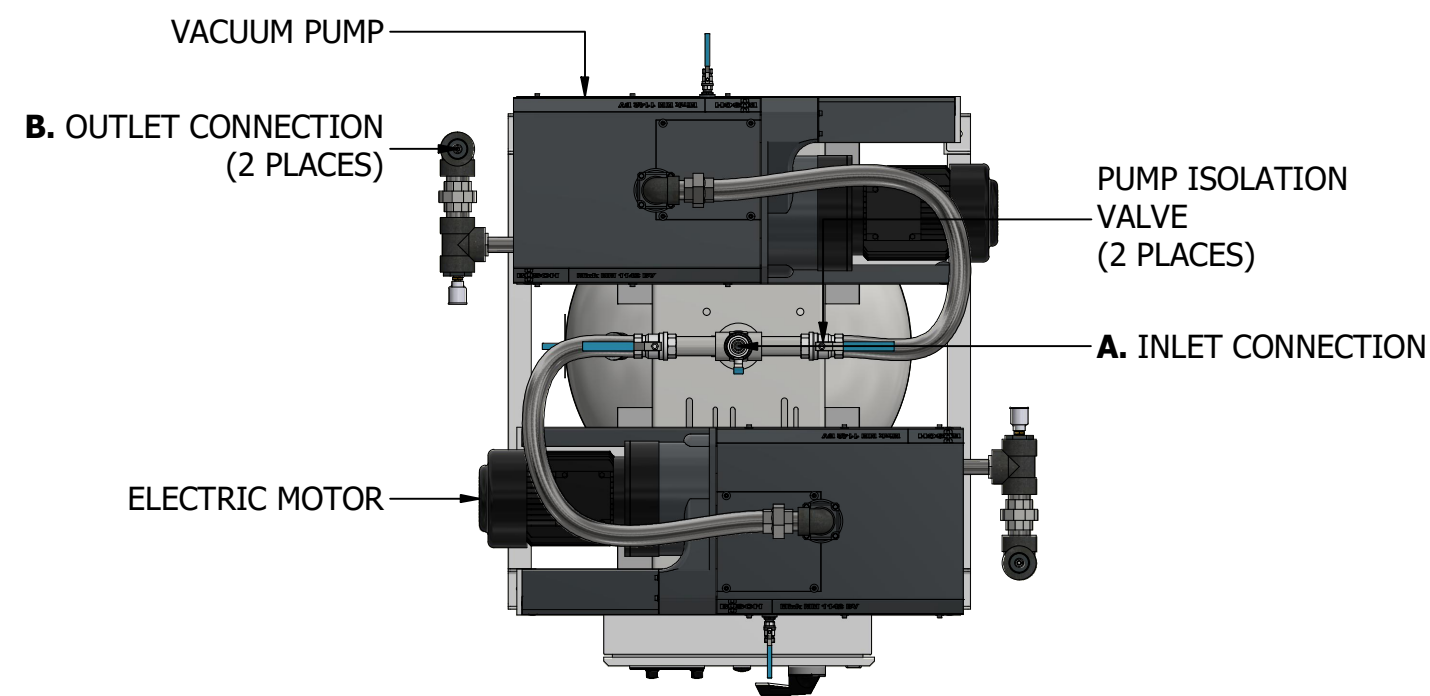

*SYSTEM CONFIGURATION DIFFERS FROM MODEL SHOWN

**380 VOLT DATA PROVIDED AT 50HZ
ALL OTHER VOLTAGES ARE RATED AT 60HZ

DIMENSIONS SUBJECT TO CHANGE WITHOUT NOTICE

ADDITIONAL MODELS AVAILABLE UPON REQUEST

MODEL	HP (kW)	A INLET NPT	B OUTLET NPT	TANK SIZE GALLON (LITRE)	PUMP SCFM @ 19" HG (LPM)		NFPA SYSTEM CAPACITIES WITH ONE COMPRESSOR ON STANDBY @ 19" HG (LPM)		WEIGHT IN LBS (KG)	SQ. FT. REQUIRED (M ²)	SYSTEM FLA (WITH ALL PUMPS RUNNING)				SYSTEM BTU/HR	SOUND LEVEL dB (A)	W (M)	L (M)	H (M)
					50 Hz Motor	60 Hz Motor	50 Hz Motor	60 Hz Motor			208V	230V	380V**	460V					
V-CCD-D-120P-TS-N-020*	2 (1.49)	1.25	1.5	120 (454)	13.3 (377)	16.0 (453)	13.3 (377)	16.0 (453)	1670 (757)	24.9 (2.32)	16	15	8	8	5,089	70	57 (1.45)	63 (1.60)	102 (2.59)
V-CCD-D-120P-TS-N-030*	3 (2.24)	1.25	1.5	120 (454)	17.5 (496)	21.0 (595)	17.5 (496)	21.0 (595)	1692 (767)	24.9 (2.32)	23	21	10	10	7,633	70	57 (1.45)	63 (1.60)	102 (2.59)
V-CCD-D-120P-TS-N-040*	4 (2.98)	1.25	1.5	120 (454)	24.2 (685)	29.0 (821)	24.2 (685)	29.0 (821)	1670 (757)	24.9 (2.32)	25	22	12	11	10,178	79	57 (1.45)	63 (1.60)	102 (2.59)
V-CCD-D-120P-TS-N-050	5 (3.73)	1.25	1.5	120 (454)	31.7 (898)	38.0 (1076)	31.7 (898)	38.0 (1076)	1692 (767)	24.9 (2.32)	30	27	12	13	12,722	79	57 (1.45)	63 (1.60)	102 (2.59)



600 Prime Place, Hauppauge
NY 11788, USA
Direct Tel: 905.764.0800
Tel: 1.877.462.6426
Fax: 1.866.440.4986