

DESICCANT AIR TREATMENT SYSTEM (100 CFM - 375 CFM)

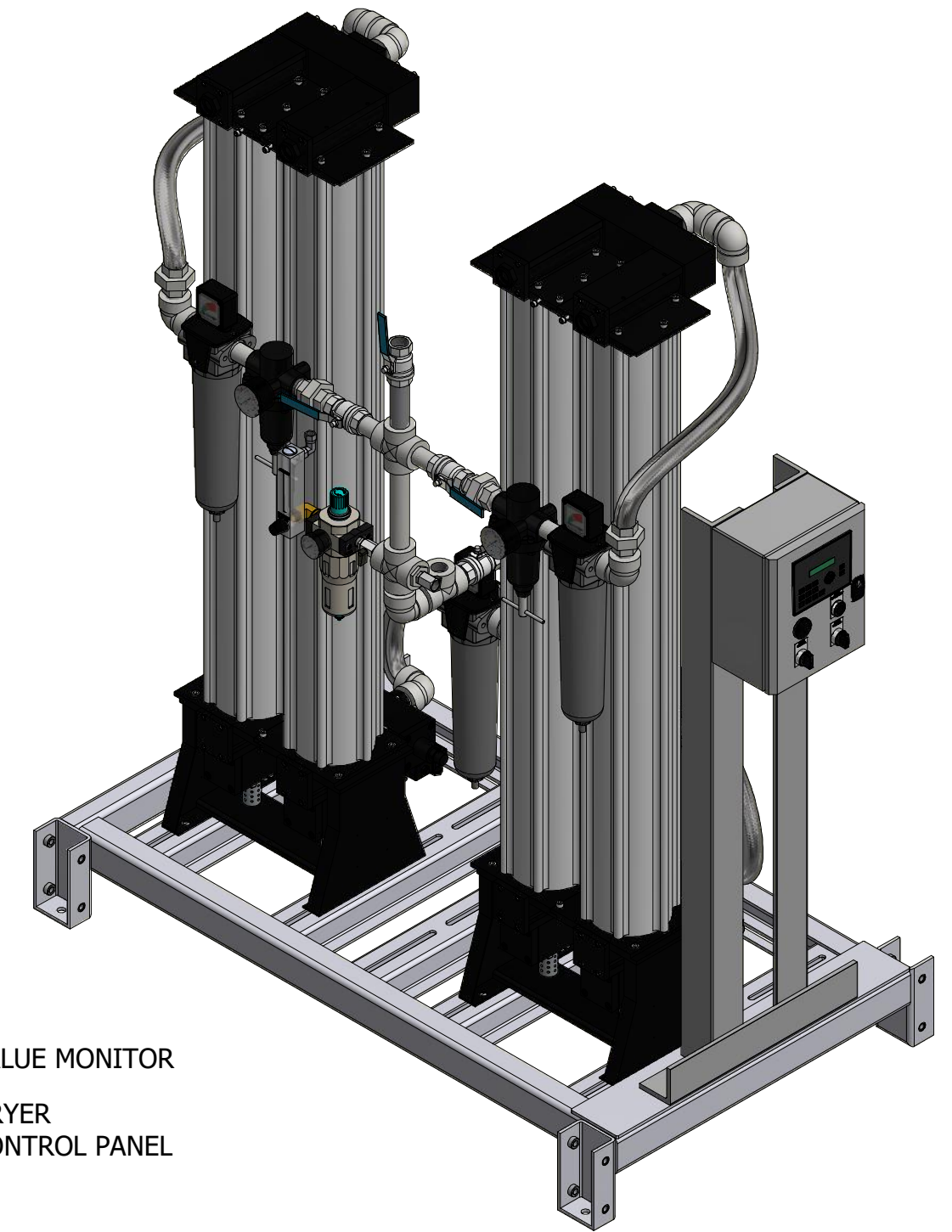

BASE DIMENSIONS 55" x 33"
DIMENSIONS SUBJECT TO CHANGE WITHOUT NOTICE

ADDITIONAL MODELS AVAILABLE UPON REQUEST

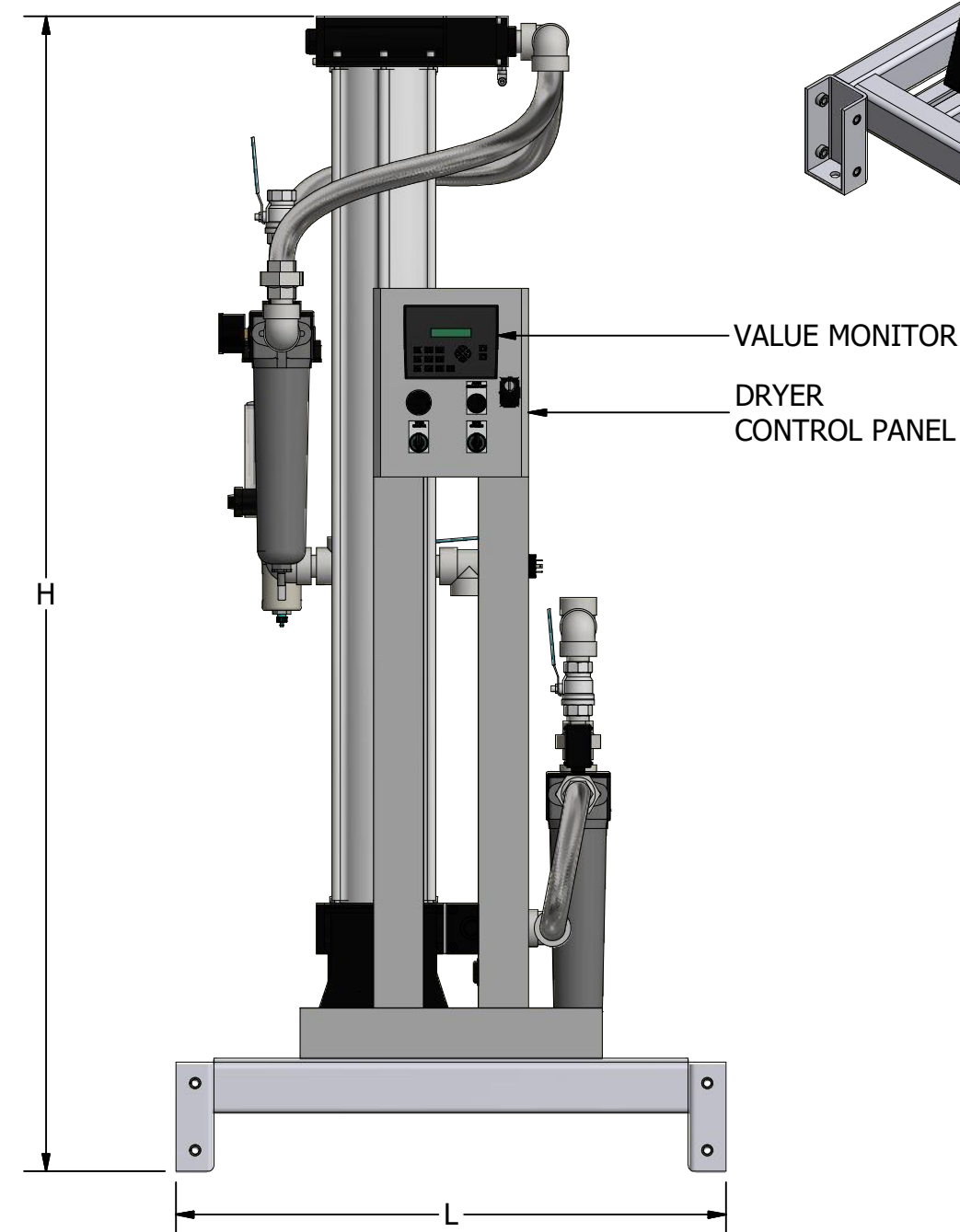
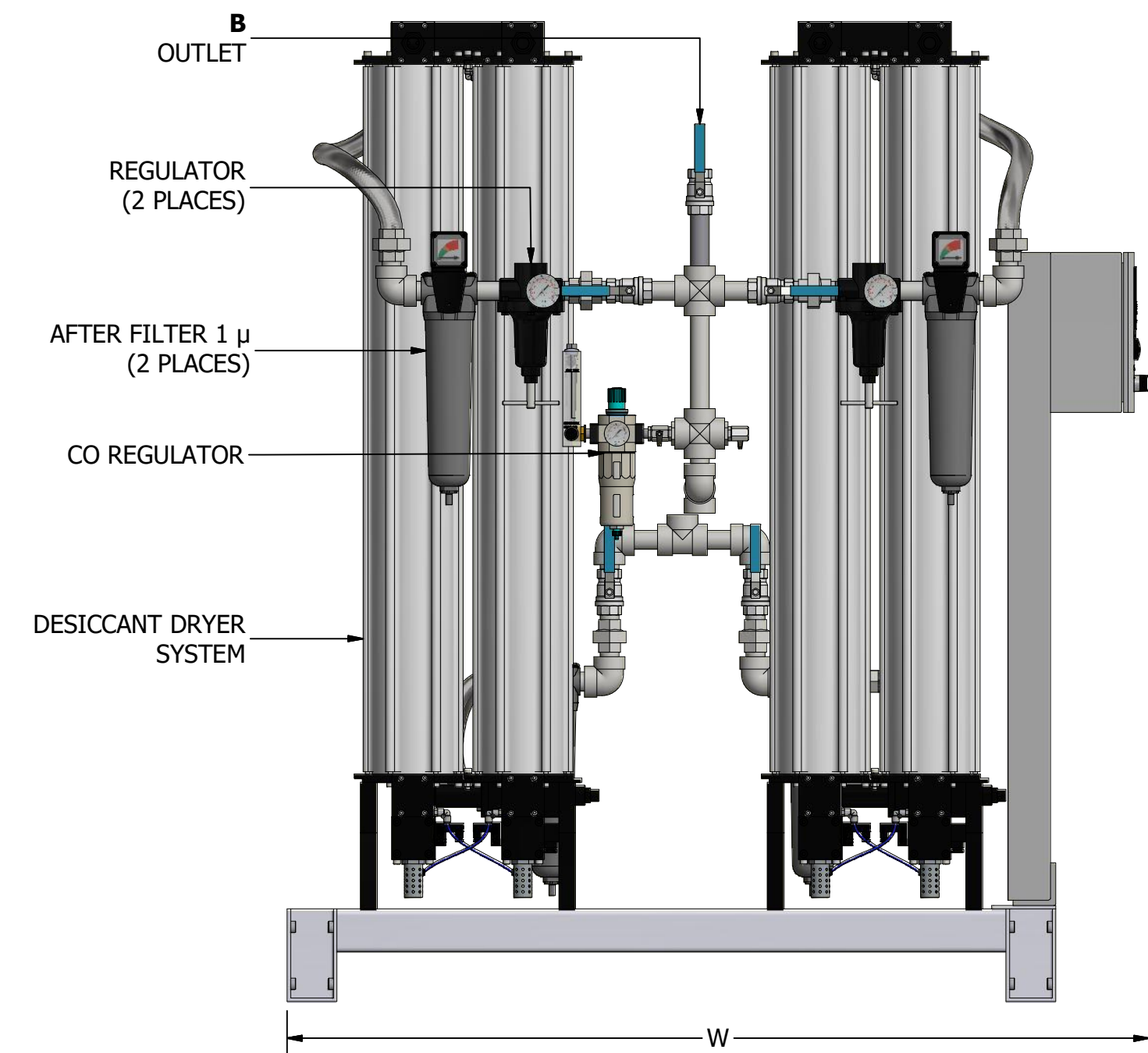
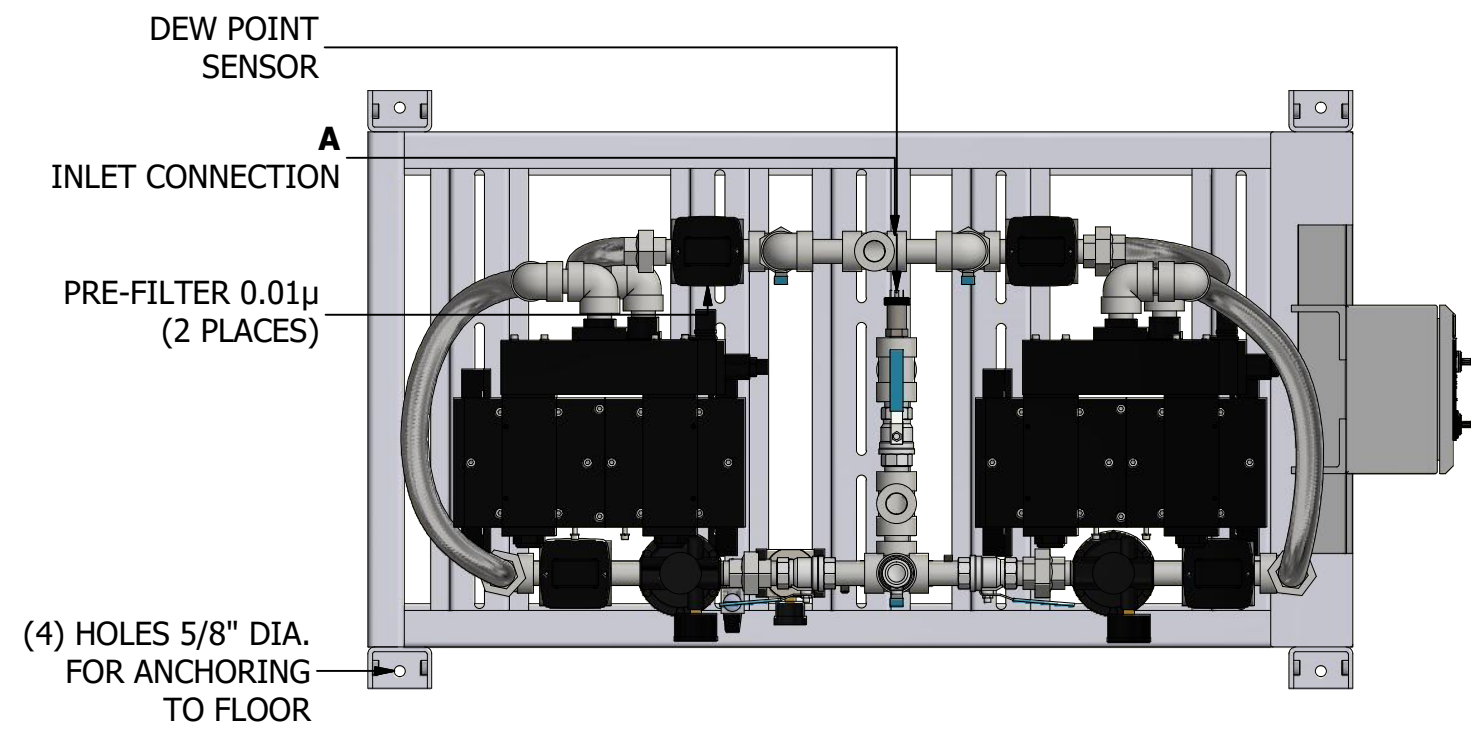

85 Fulton Way, Richmond Hill
Ontario, L4B 2N4 Canada
71 East Industry Court
Deer Park, NY 11729
Direct Tel: 905.764.0800
Tel: 1.877.462.6426
Fax: 1.866.440.4986

MODEL	A INLET NPT	B OUTLET NPT	DRYER SCFM (LPM)	WEIGHT IN LBS (KG)	SQ. FT. REQUIRED (M ²)	W (M)	L (M)	H (M)
A-X-ADAD-B-445	1.0	1.0	100 (2832)	679 (308)	14.2 (1.32)	62 (1.57)	33 (0.83)	69 (1.75)
A-X-ADAD-B-446	1.0	1.0	125 (3540)	737 (334)	14.2 (1.32)	62 (1.57)	33 (0.83)	81 (2.06)
A-X-ADAD-B-447	1.5	1.5	200 (5663)	1147 (520)	14.2 (1.32)	62 (1.57)	33 (0.83)	69 (1.75)
A-X-ADAD-B-448	1.5	1.5	250 (7079)	1251 (567)	14.2 (1.32)	62 (1.57)	33 (0.83)	82 (2.08)
A-X-ADAD-B-449	2.0	2.0	300 (8495)	1323 (600)	15.5 (1.44)	62 (1.57)	36 (0.91)	69 (1.75)
A-X-ADAD-B-450	2.0	2.0	375 (10619)	1455 (660)	15.5 (1.44)	62 (1.57)	36 (0.91)	82 (2.08)