

ROTARY VANE - DRY DUPLEX STACK MOUNTED VACUUM SYSTEM (BECKER) (7.5 HP - 15 HP)

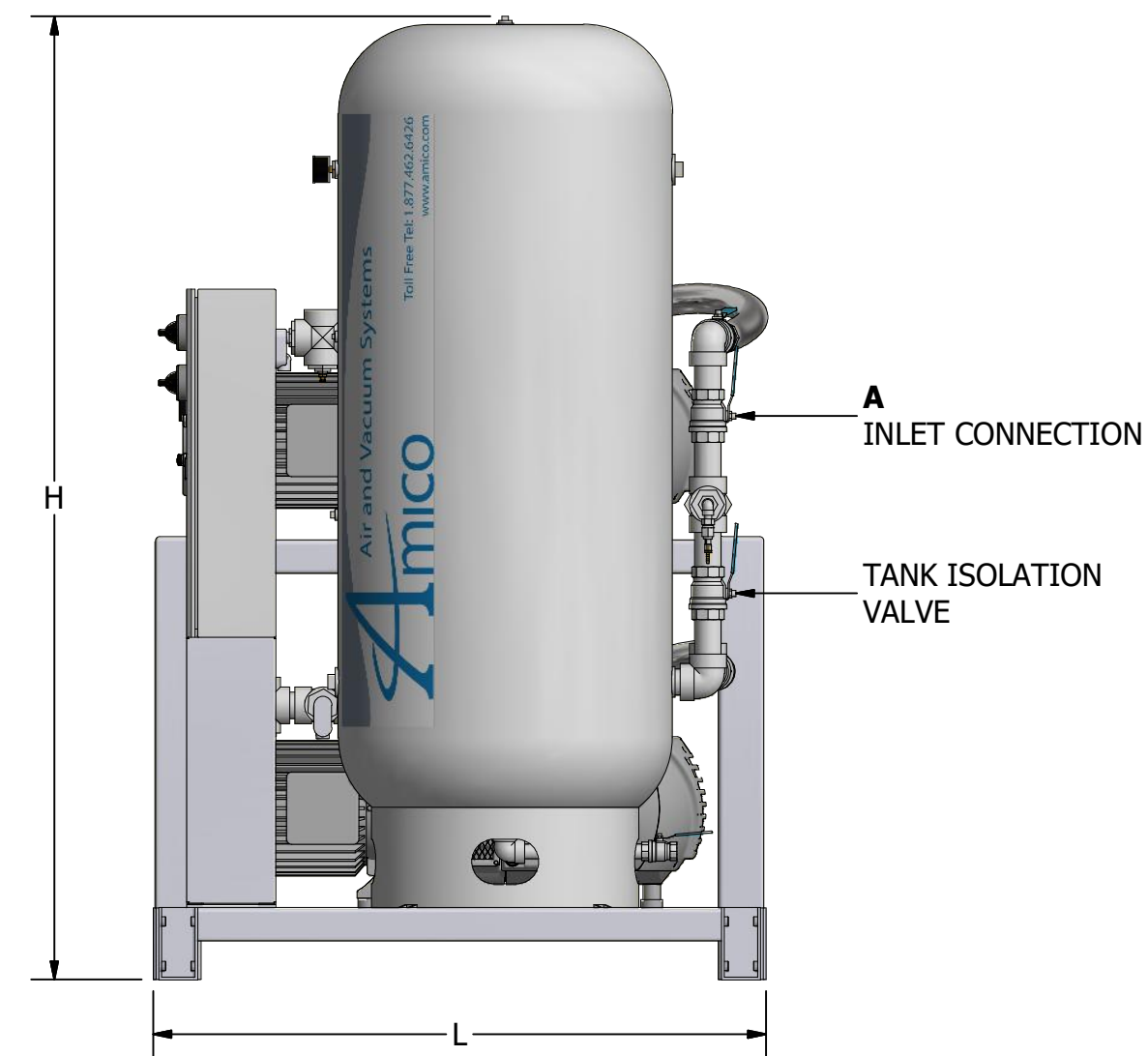
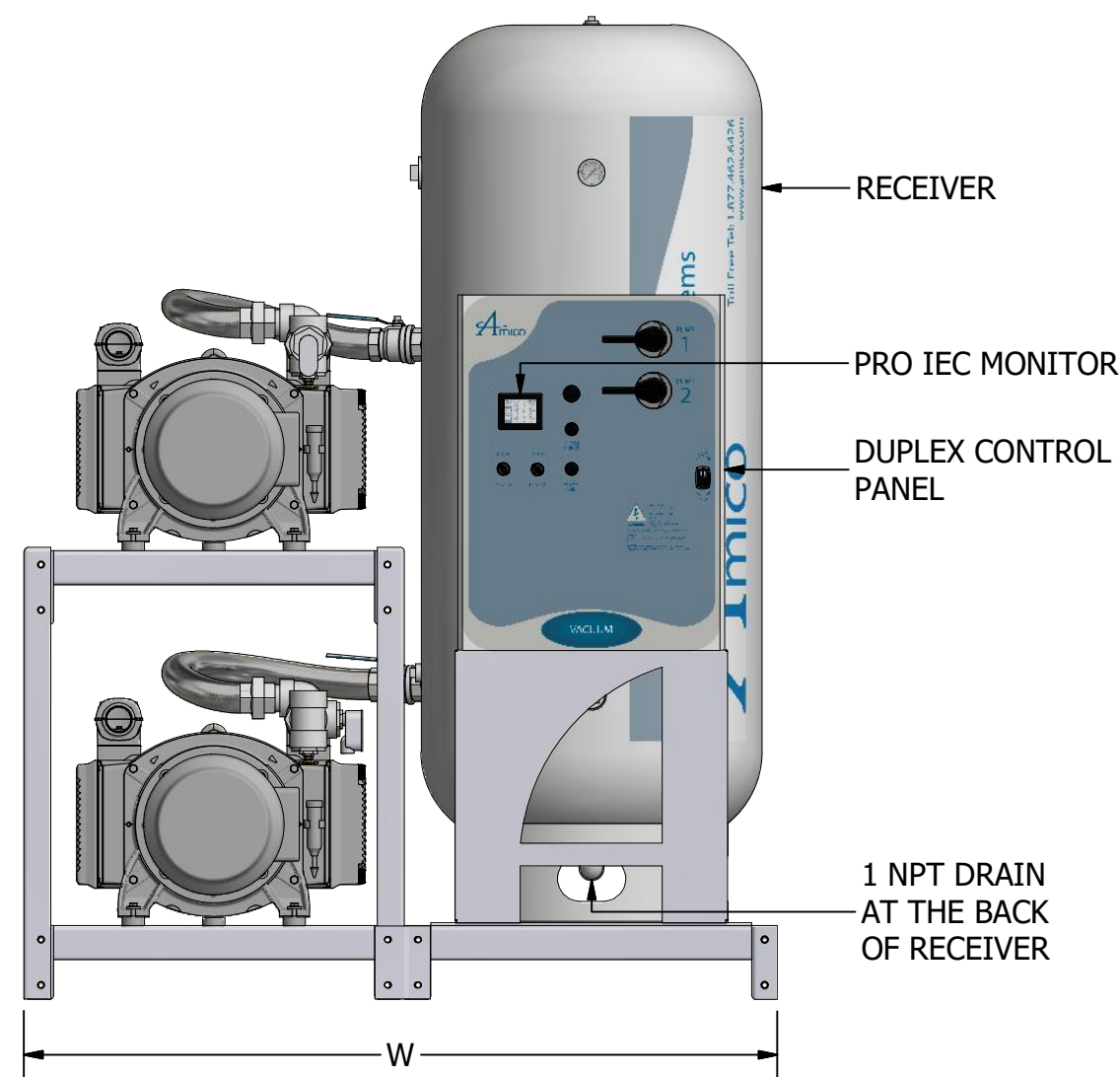
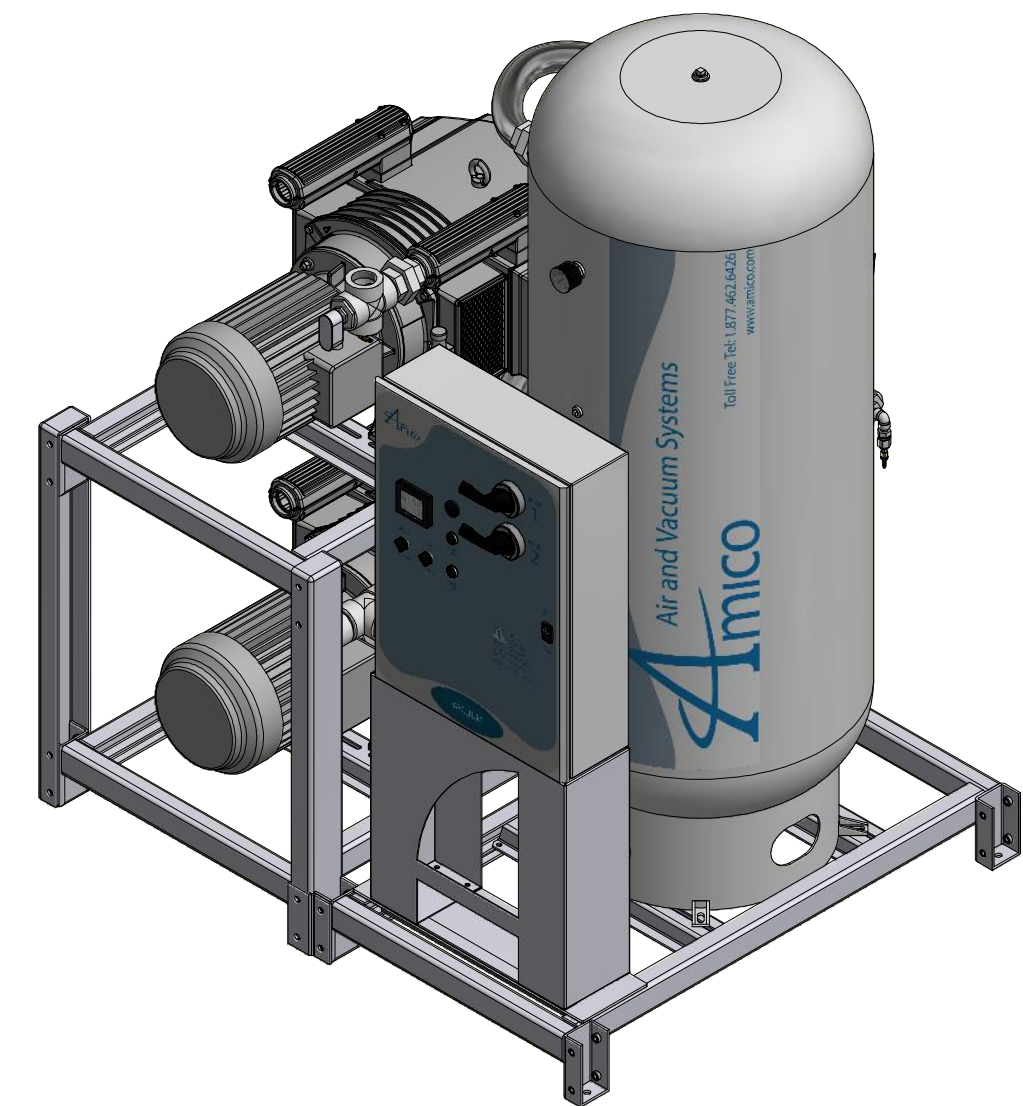
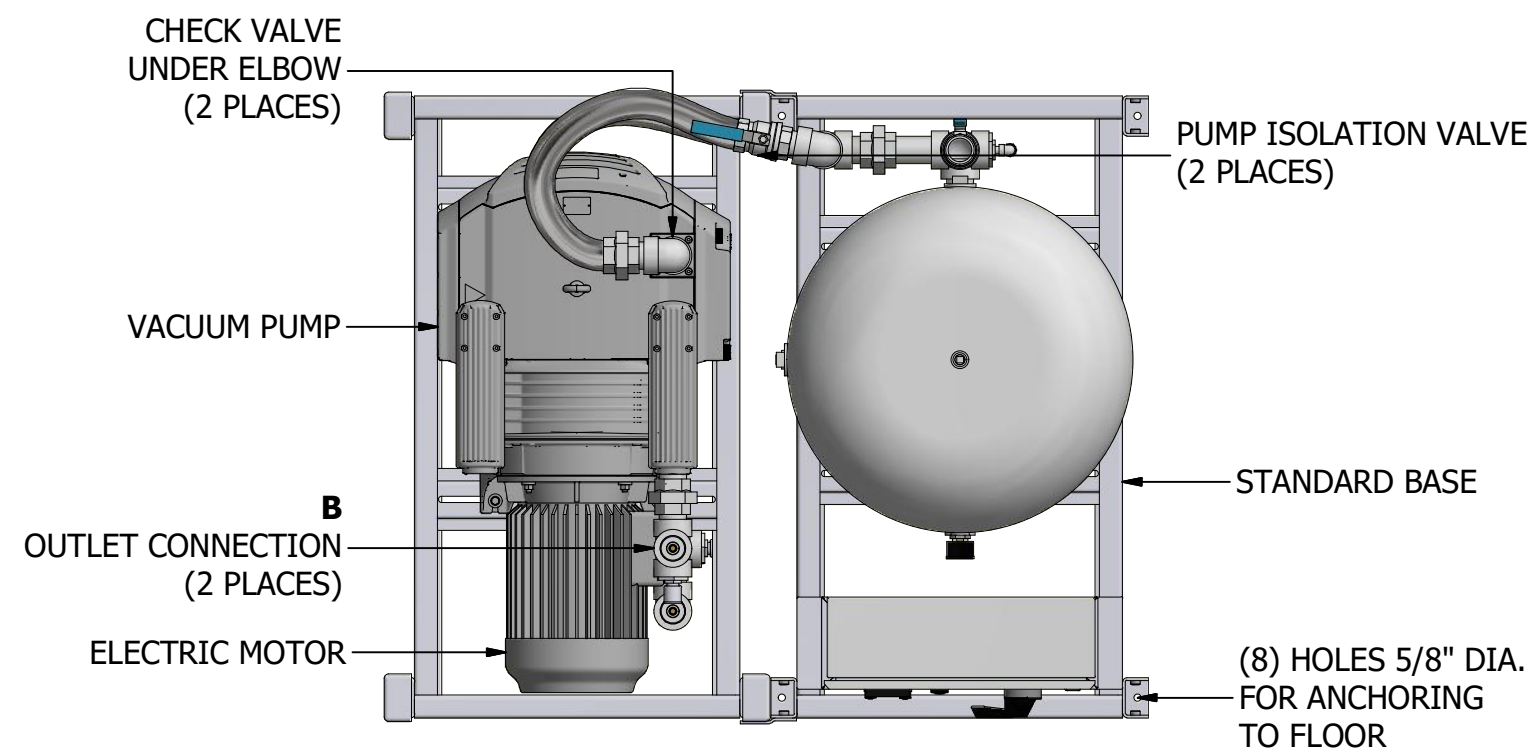

*SYSTEM CONFIGURATION DIFFERS FROM MODEL SHOWN

**FOR 380 VOLT DATA CONTACT AMICO SOURCE

ADDITIONAL MODELS AVAILABLE UPON REQUEST

DIMENSIONS SUBJECT TO CHANGE WITHOUT NOTICE

MODEL	HP (kW)	A INLET NPT	B OUTLET NPT	TANK SIZE GALLON (LITRE)	PUMP SCFM @ 19" HG (LPM)		NFPA SYSTEM CAPACITIES WITH ONE COMPRESSOR ON STANDBY @ 19" HG (LPM)		WEIGHT IN LBS (KG)	SQ. FT. REQUIRED (M ²)	SYSTEM FLA (WITH ALL PUMPS RUNNING)				SYSTEM BTU/HR	SOUND LEVEL dB (A)	W (M)	L (M)	H (M)
					50 Hz Motor	60 Hz Motor	50 Hz Motor	60 Hz Motor			208V	230V	380V**	460V					
V-RVD-D-200P-SS-N-075*	7.5 (5.59)	3.0	2.0	200 (757)	31.7 (898)	38.0 (1076)	31.7 (898)	38.0 (1076)	2442 (1108)	30.2 (2.81)	65	60	-	30	19,083	77	67 (1.70)	65 (1.65)	91 (2.31)
V-RVD-D-200P-SS-N-100*	10.0 (7.46)	3.0	2.0	200 (757)	42.5 (1203)	51.0 (1444)	42.5 (1203)	51.0 (1444)	2322 (1053)	30.2 (2.81)	75	69	-	34	25,444	79	67 (1.70)	65 (1.65)	91 (2.31)
V-RVD-D-200P-SS-N-101	10.0 (7.46)	3.0	2.0	200 (757)	45.8 (1297)	55.0 (1557)	45.8 (1297)	55.0 (1557)	2502 (1135)	30.2 (2.81)	75	69	-	34	25,444	79	67 (1.70)	65 (1.65)	91 (2.31)
V-RVD-D-200P-SS-N-150*	15.0 (11.2)	4.0	2.0	200 (757)	66.7 (1889)	80.0 (2265)	66.7 (1889)	80.0 (2265)	2960 (1343)	34.9 (3.24)	111	101	-	51	38,166	79	74 (1.88)	68 (1.73)	91 (2.31)



85 Fulton Way, Richmond Hill
Ontario, L4B 2N4 Canada
71 East Industry Court
Deer Park, NY 11729
Direct Tel: 905.764.0800
Tel: 1.877.462.6426
Fax: 1.866.440.4986