

# ROTARY VANE - DRY DUPLEX "SPACE SAVER" VACUUM SYSTEM (BUSCH) (1.2 HP - 8.9 HP)

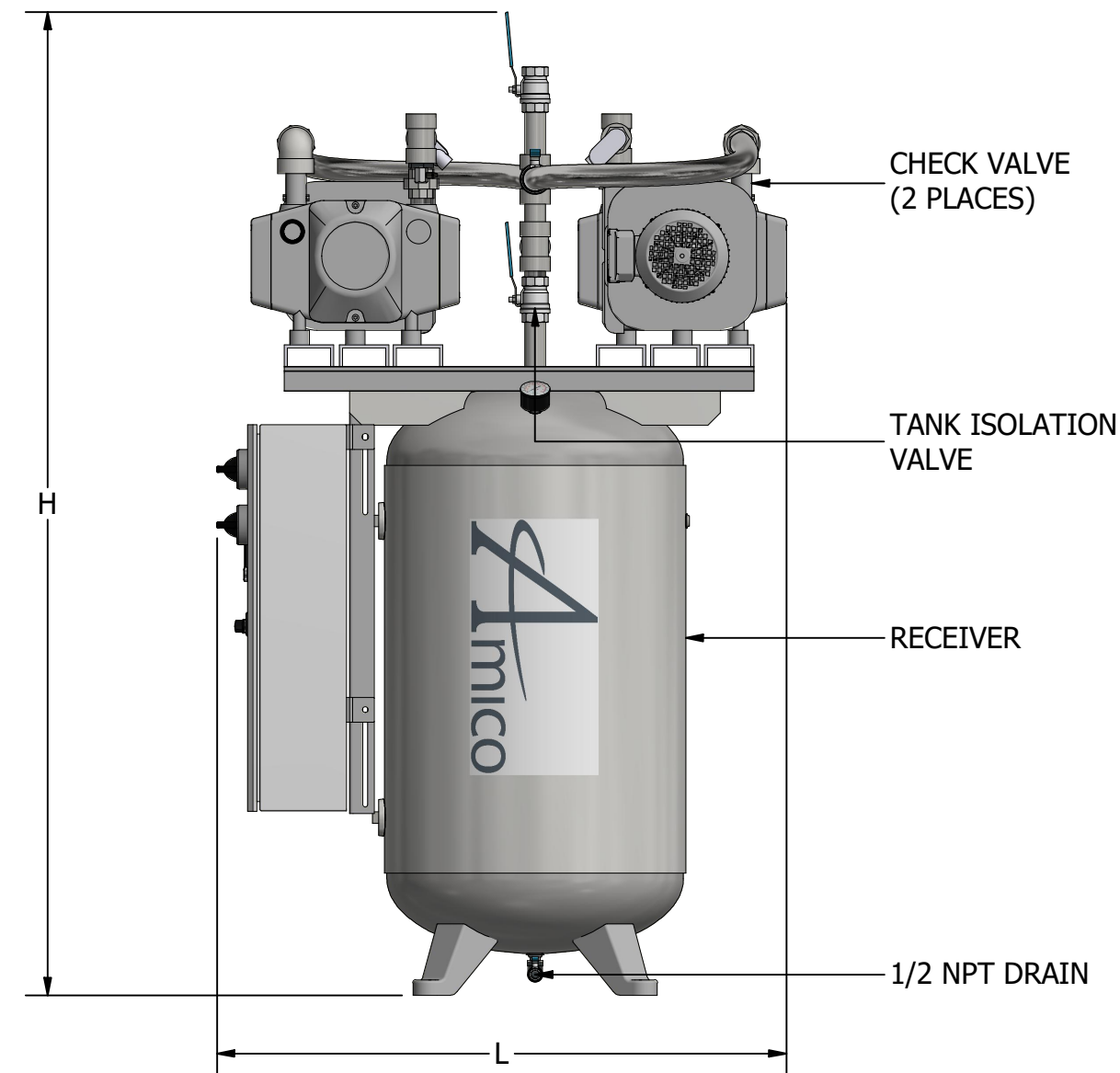
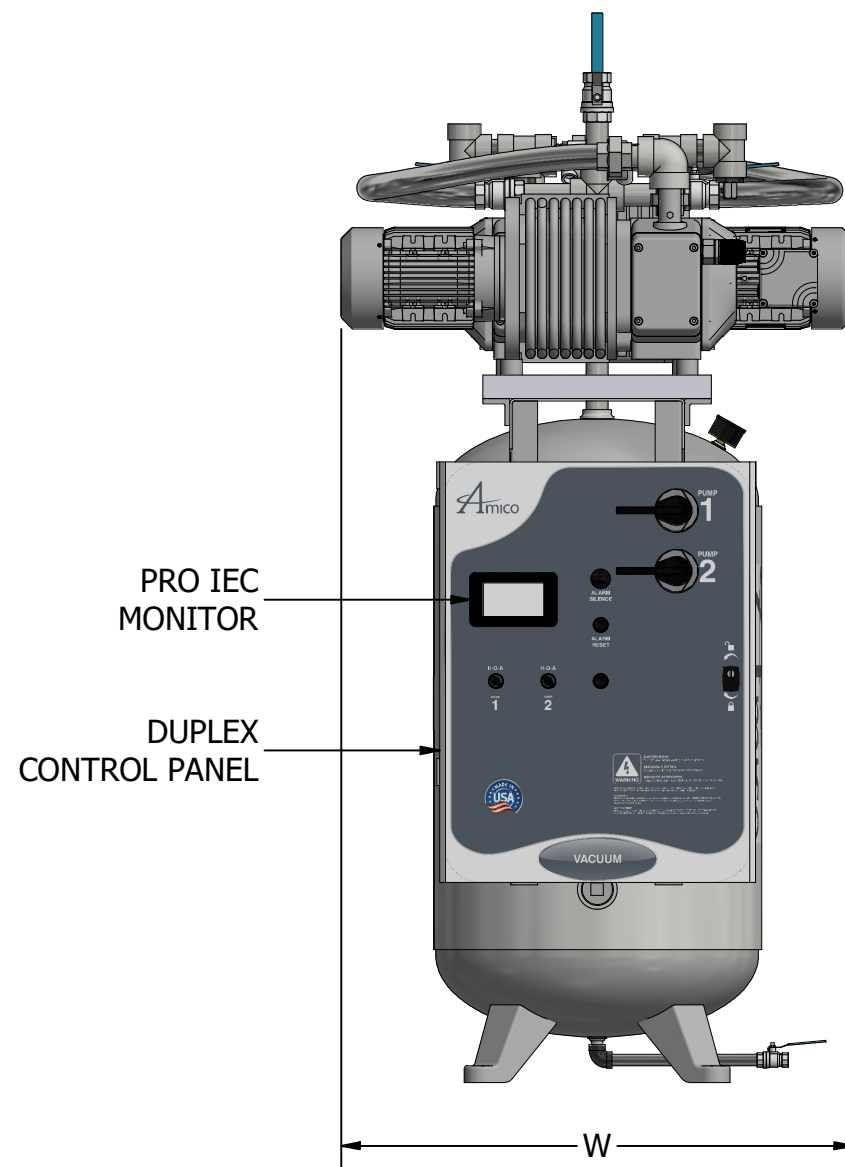
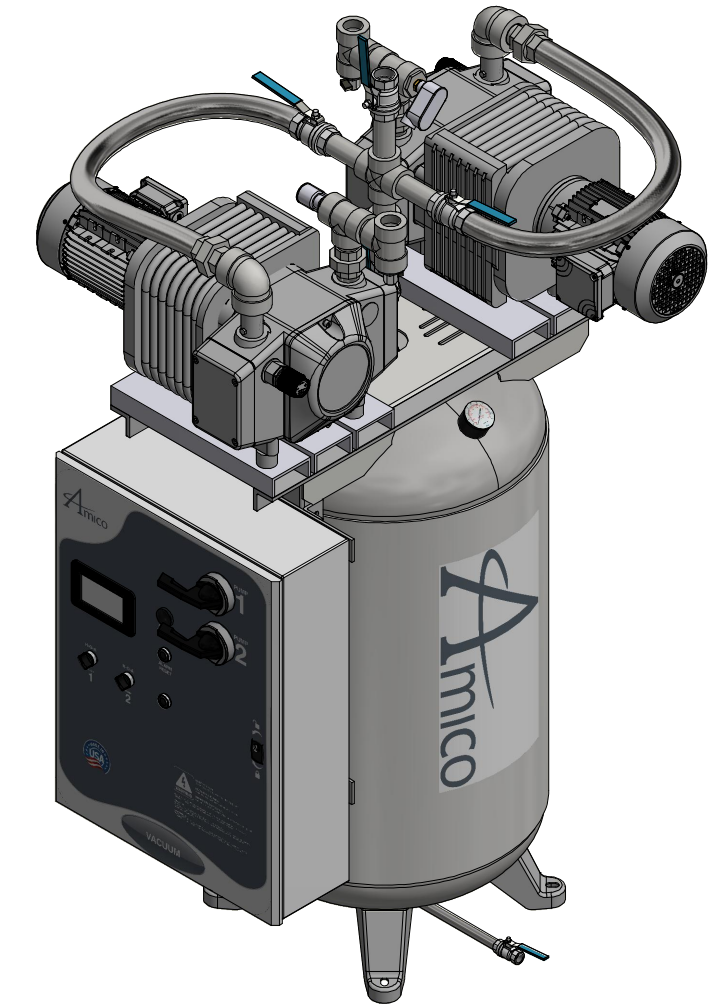
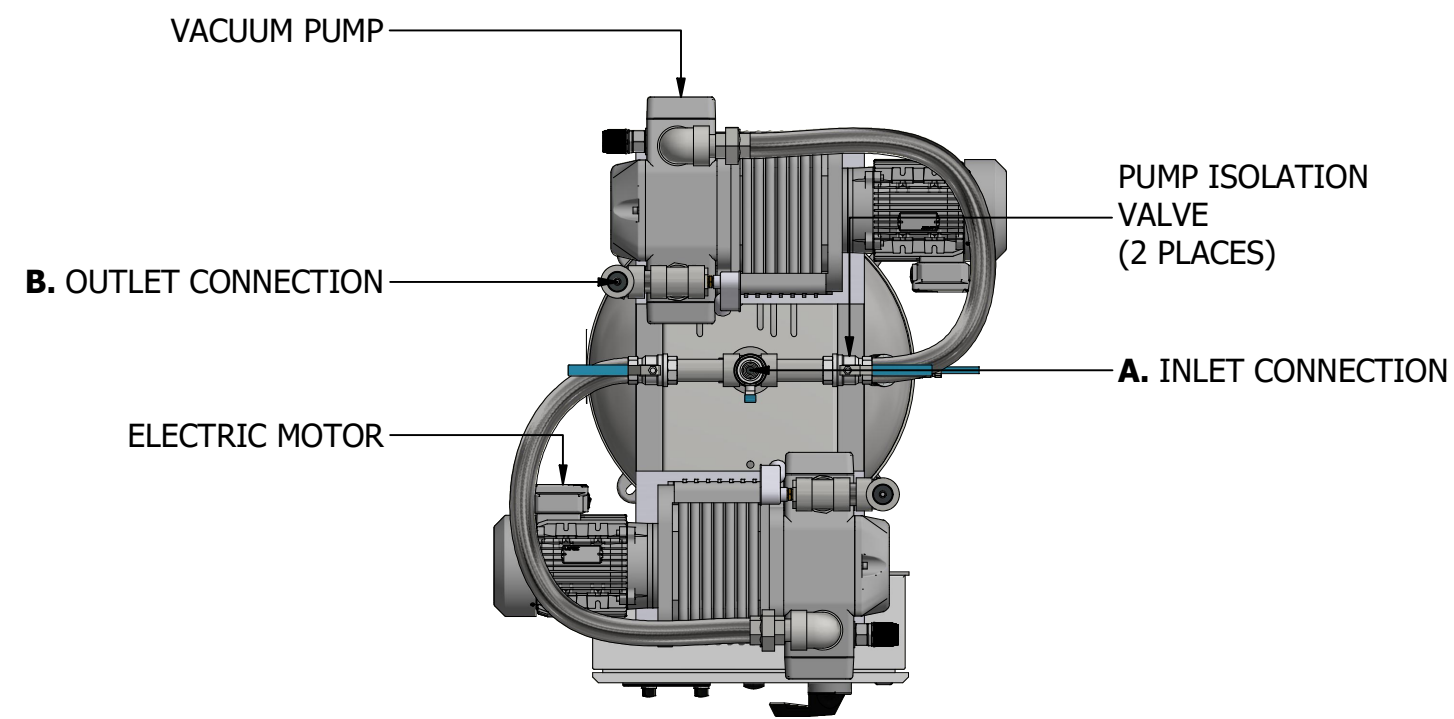

DIMENSIONS SUBJECT TO CHANGE WITHOUT NOTICE

\*SYSTEM CONFIGURATION DIFFERS FROM MODEL SHOWN

\*\*380 VOLT DATA PROVIDED AT 50HZ  
ALL OTHER VOLTAGES ARE RATED AT 60HZ

ADDITIONAL MODELS AVAILABLE UPON REQUEST

MODEL	HP (kW)	A INLET NPT	B OUTLET NPT	TANK SIZE GALLON (LITRE)	PUMP SCFM @ 19" HG (LPM)		NFPA SYSTEM CAPACITIES WITH ONE COMPRESSOR ON STANDBY @ 19" HG (LPM)		WEIGHT IN LBS (KG)	SQ. FT. REQUIRED (M <sup>2</sup> )	SYSTEM FLA (WITH ALL PUMPS RUNNING)				SYSTEM BTU/HR	SOUND LEVEL dB (A)	W (M)	L (M)	H (M)
					50 Hz Motor	60 Hz Motor	50 Hz Motor	60 Hz Motor			208V	230V	380V**	460V					
V-RVD-D-080P-TS-N-012*	1.2 (0.89)	0.75	1.0	80 (303)	4.4 (125)	5.3 (150)	4.4 (125)	5.3 (150)	721 (327)	13.4 (1.25)	14	14	8	8	3,053	66	44 (1.12)	44 (1.12)	83 (2.11)
V-RVD-D-080P-TS-N-017*	1.7 (1.27)	0.75	1.0	80 (303)	6.7 (190)	8.0 (227)	6.7 (190)	8.0 (227)	775 (352)	13.4 (1.25)	18	17	9	9	4,326	70	44 (1.12)	44 (1.12)	83 (2.11)
V-RVD-D-080P-TS-N-032	3.2 (2.39)	1.25	1.25	80 (303)	11.3 (320)	13.5 (382)	11.3 (320)	13.5 (382)	955 (433)	15.9 (1.48)	22	20	10	10	8,142	76	44 (1.12)	52 (1.32)	83 (2.11)
V-RVD-D-080P-TS-N-046*	4.6 (3.43)	1.25	1.25	80 (303)	14.2 (402)	17.0 (481)	14.2 (402)	17.0 (481)	999 (453)	16.6 (1.54)	31	29	14	14	11,704	77	46 (1.17)	52 (1.32)	83 (2.11)
V-RVD-D-120P-TS-N-056*	5.6 (4.18)	1.25	1.25	120 (454)	17.5 (496)	21.0 (595)	17.5 (496)	21.0 (595)	1319 (598)	16.7 (1.55)	35	34	18	17	14,249	76	48 (1.22)	50 (1.27)	86 (2.18)
V-RVD-D-120P-TS-N-089*	8.9 (6.64)	1.5	1.5	120 (454)	23.3 (660)	28.0 (793)	23.3 (660)	28.0 (793)	1387 (629)	17.3 (1.61)	53	51	26	26	22,645	77	48 (1.22)	52 (1.32)	90 (2.29)



600 Prime Place, Hauppauge  
NY 11788, USA  
Direct Tel: 905.764.0800  
Tel: 1.877.462.6426  
Fax: 1.866.440.4986