

ROTARY VANE - LUBRICATED DUPLEX STACK MOUNTED VACUUM SYSTEM (1.0 HP - 25.0 HP)

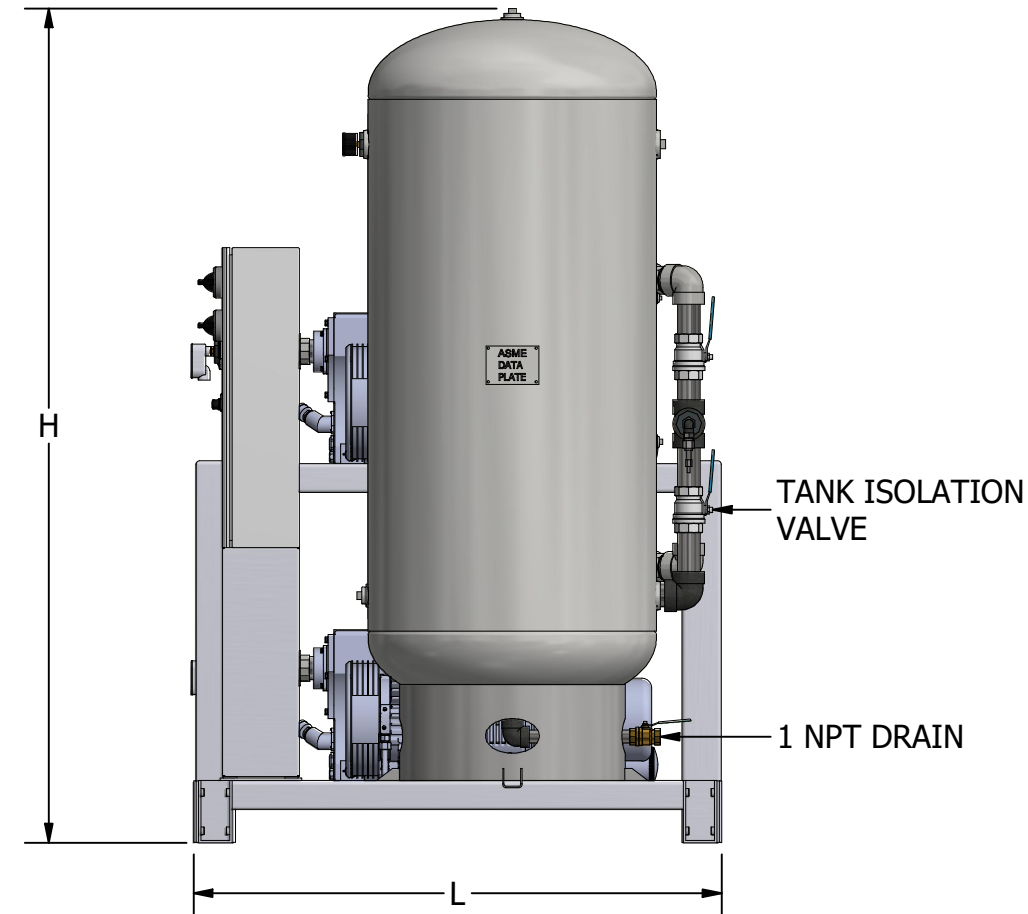
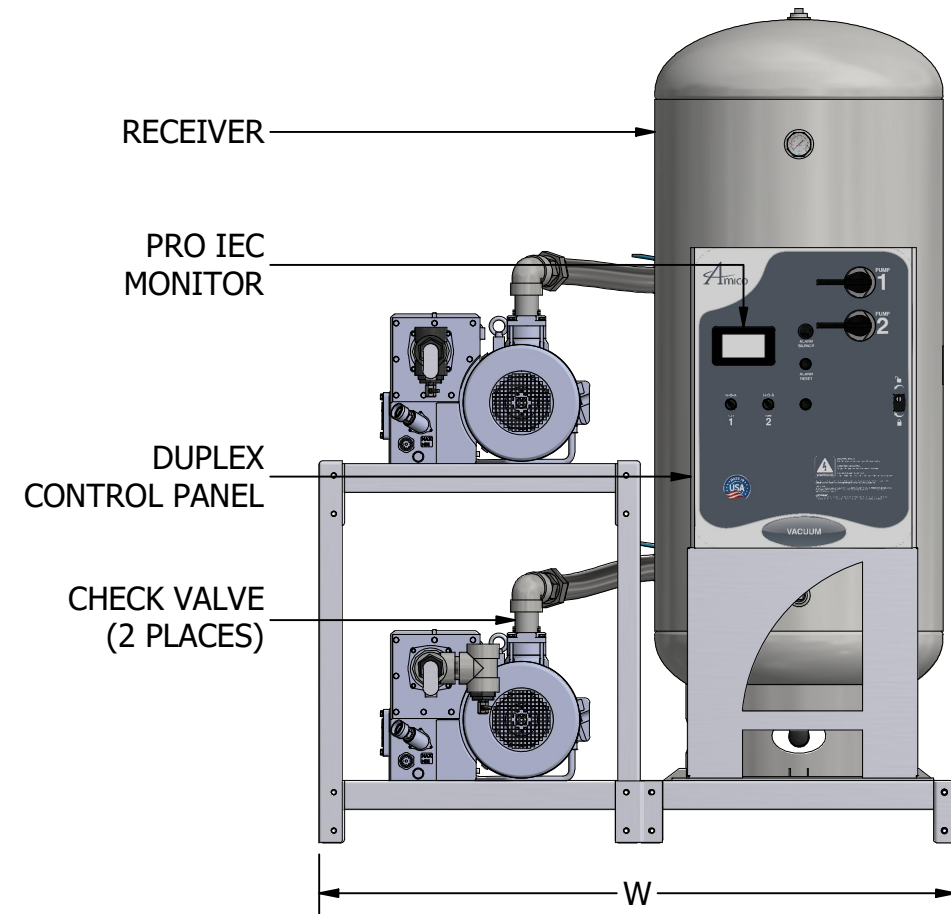
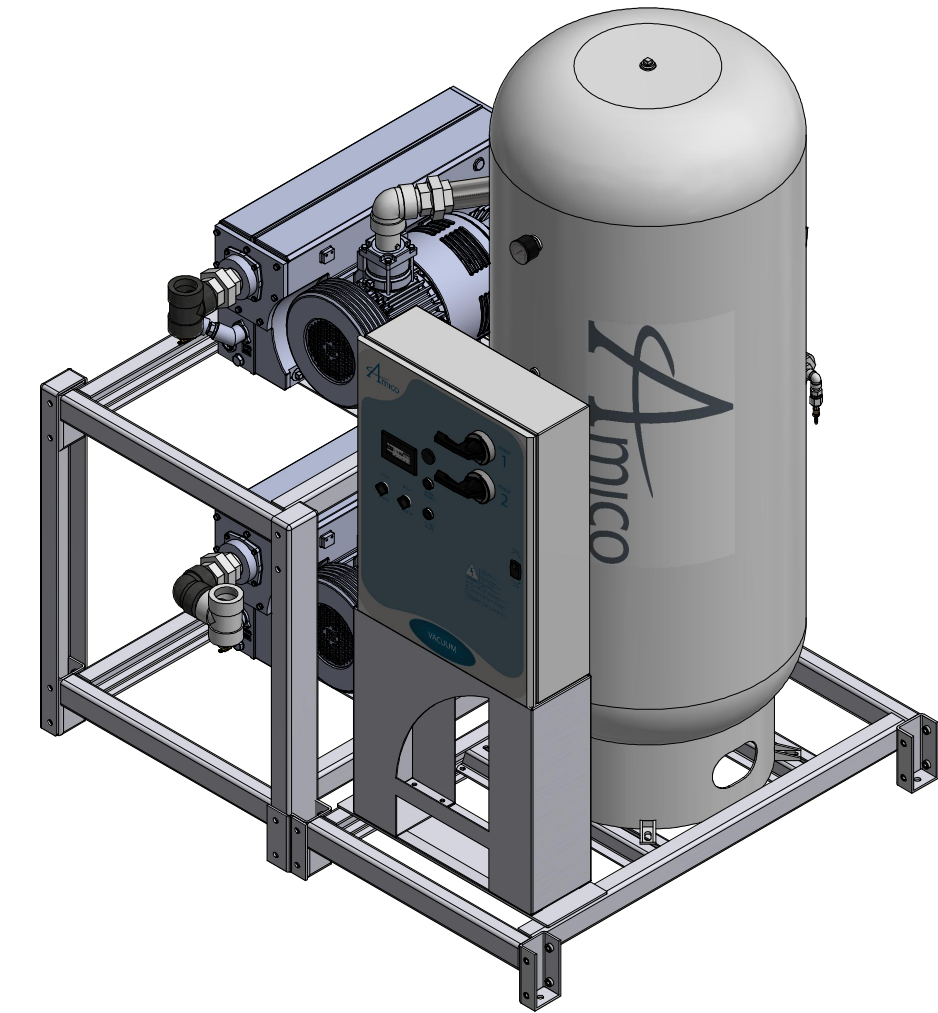
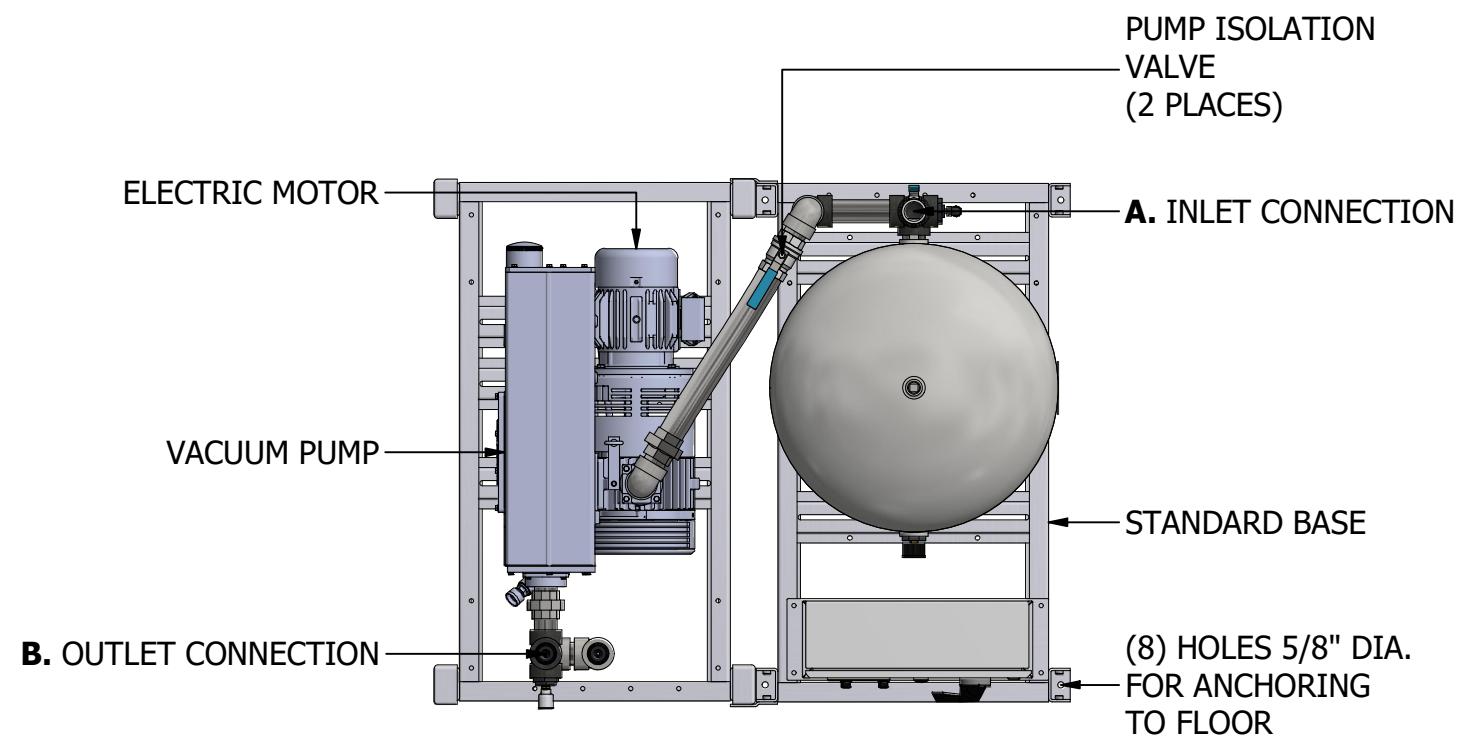

DIMENSIONS SUBJECT TO CHANGE WITHOUT NOTICE

MODEL	HP (KW)	A INLET NPT	B OUTLET NPT	TANK SIZE GALLON (LITRE)	PUMP SCFM @ 19" HG (LPM)		NFPA SYSTEM CAPACITIES WITH ONE COMPRESSOR ON STANDBY @ 19" HG (LPM)		WEIGHT IN LBS (KG)	SQ. FT. REQUIRED (M ²)	SYSTEM FLA (WITH ALL PUMPS RUNNING)				SYSTEM BTU/HR	SOUND LEVEL dB (A)	W (M)	L (M)	H (M)
					50 Hz Motor	60 Hz Motor	50 Hz Motor	60 Hz Motor			208V	230V	380V**	460V					
V-RVL-D-200P-SS-N-010*	1 (0.75)	0.75	0.75	200 (757)	4.0 (113)	4.8 (136)	4.0 (113)	4.8 (136)	1185 (537)	25.6 (2.38)	11	11	6	6	2,544	66	67 (1.70)	55 (1.40)	91 (2.31)
V-RVL-D-200P-SS-N-015*	1.5 (1.12)	1.25	1.25	200 (757)	5.8 (164)	7.0 (198)	5.8 (164)	7.0 (198)	1359 (616)	25.6 (2.38)	13	13	7	6	3,817	63	67 (1.70)	55 (1.40)	91 (2.31)
V-RVL-D-200P-SS-N-020*	2 (1.49)	1.25	1.25	200 (757)	9.2 (261)	11.0 (311)	9.2 (261)	11.0 (311)	1387 (629)	25.6 (2.38)	15	15	8	7	5,089	66	67 (1.70)	55 (1.40)	91 (2.31)
V-RVL-D-200P-SS-N-030*	3 (2.24)	1.25	1.25	200 (757)	14.2 (402)	17.0 (481)	14.2 (402)	17.0 (481)	1491 (676)	25.6 (2.38)	21	20	11	11	7,633	66	67 (1.70)	55 (1.40)	91 (2.31)
V-RVL-D-200P-SS-N-050*	5 (3.73)	1.25	1.25	200 (757)	21.7 (614)	26.0 (736)	21.7 (614)	26.0 (736)	1543 (700)	25.6 (2.38)	32	30	16	15	12,722	68	67 (1.70)	55 (1.40)	91 (2.31)
V-RVL-D-200P-SS-N-052	5 (3.73)	2.0	2.0	200 (757)	30.8 (872)	37.0 (1048)	30.8 (872)	37.0 (1048)	1682 (763)	25.6 (2.38)	33	30	18	15	12,722	72	67 (1.70)	55 (1.40)	91 (2.31)
V-RVL-D-200P-SS-N-075*	7.5 (5.59)	2.0	2.0	200 (757)	43.3 (1226)	52.0 (1472)	43.3 (1226)	52.0 (1472)	2067 (938)	25.6 (2.38)	48	47	25	24	19,083	74	67 (1.70)	55 (1.40)	91 (2.31)
V-RVL-D-200P-SS-N-100*	10 (7.46)	2.0	2.0	200 (757)	54.2 (1535)	65.0 (1841)	54.2 (1535)	65.0 (1841)	2117 (960)	25.6 (2.38)	58	56	29	28	25,444	74	67 (1.70)	55 (1.40)	91 (2.31)
V-RVL-D-200P-SS-N-101*	10 (7.46)	2.0	2.0	200 (757)	64.2 (1818)	77.0 (2180)	64.2 (1818)	77.0 (2180)	2347 (1065)	25.6 (2.38)	58	56	29	28	25,444	76	67 (1.70)	55 (1.40)	91 (2.31)
V-RVL-D-200P-SS-N-150*	15 (11.2)	3.0	3.0	200 (757)	92.5 (2619)	111.0 (3143)	92.5 (2619)	111.0 (3143)	3492 (1584)	51.1 (4.75)	104	79	47	41	38,166	79	92 (2.34)	80 (2.03)	91 (2.31)
V-RVL-D-200P-SS-N-200*	20 (14.9)	3.0	3.0	200 (757)	114.2 (3234)	137.0 (3879)	114.2 (3234)	137.0 (3879)	3894 (1766)	51.1 (4.75)	128	108	58	54	50,889	79	92 (2.34)	80 (2.03)	93 (2.39)
V-RVL-D-200P-SS-N-250*	25 (18.6)	3.0	3.0	200 (757)	140.0 (3964)	168.0 (4757)	140.0 (3964)	168.0 (4757)	4378 (1986)	51.1 (4.75)	140	128	76	64	63,611	79	92 (2.34)	80 (2.03)	93 (2.39)

*SYSTEM CONFIGURATION DIFFERS FROM MODEL SHOWN

**380 VOLT DATA PROVIDED AT 50HZ
ALL OTHER VOLTAGES ARE RATED AT 60HZ

ADDITIONAL MODELS AVAILABLE UPON REQUEST



600 Prime Place, Hauppauge
NY 11788, USA
Direct Tel: 905.764.0800
Tel: 1.877.462.6426
Fax: 1.866.440.4986