

ROTARY VANE - LUBRICATED QUADRAPLEX STACK MOUNTED VACUUM SYSTEM (1.0 HP - 25.0 HP)

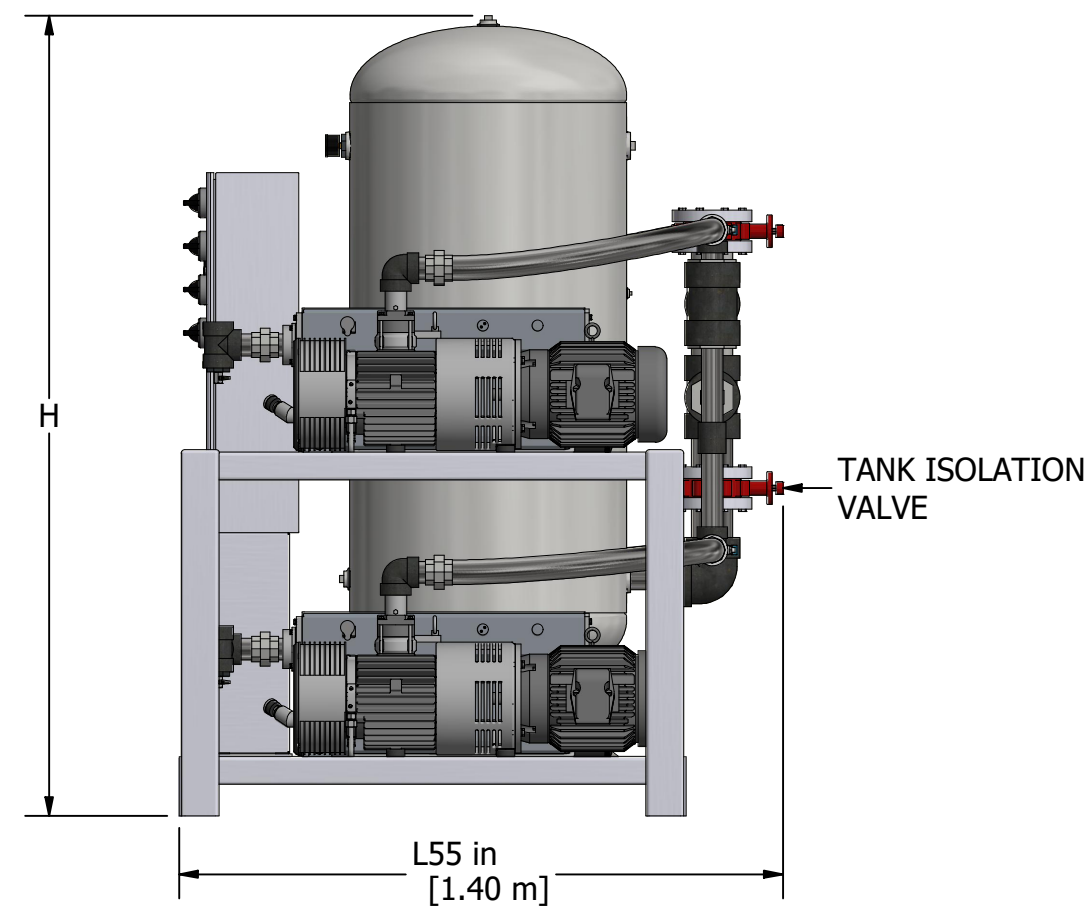
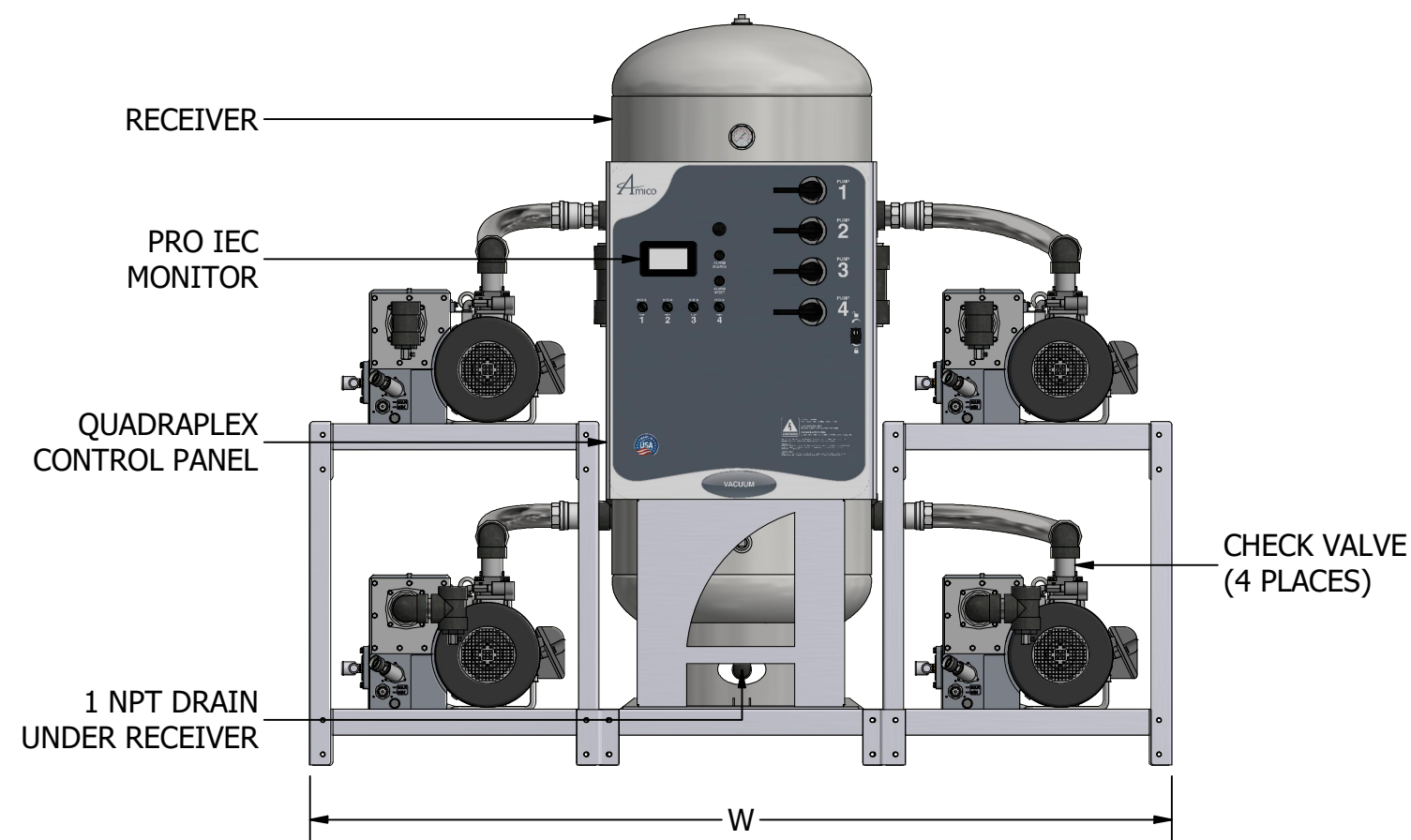
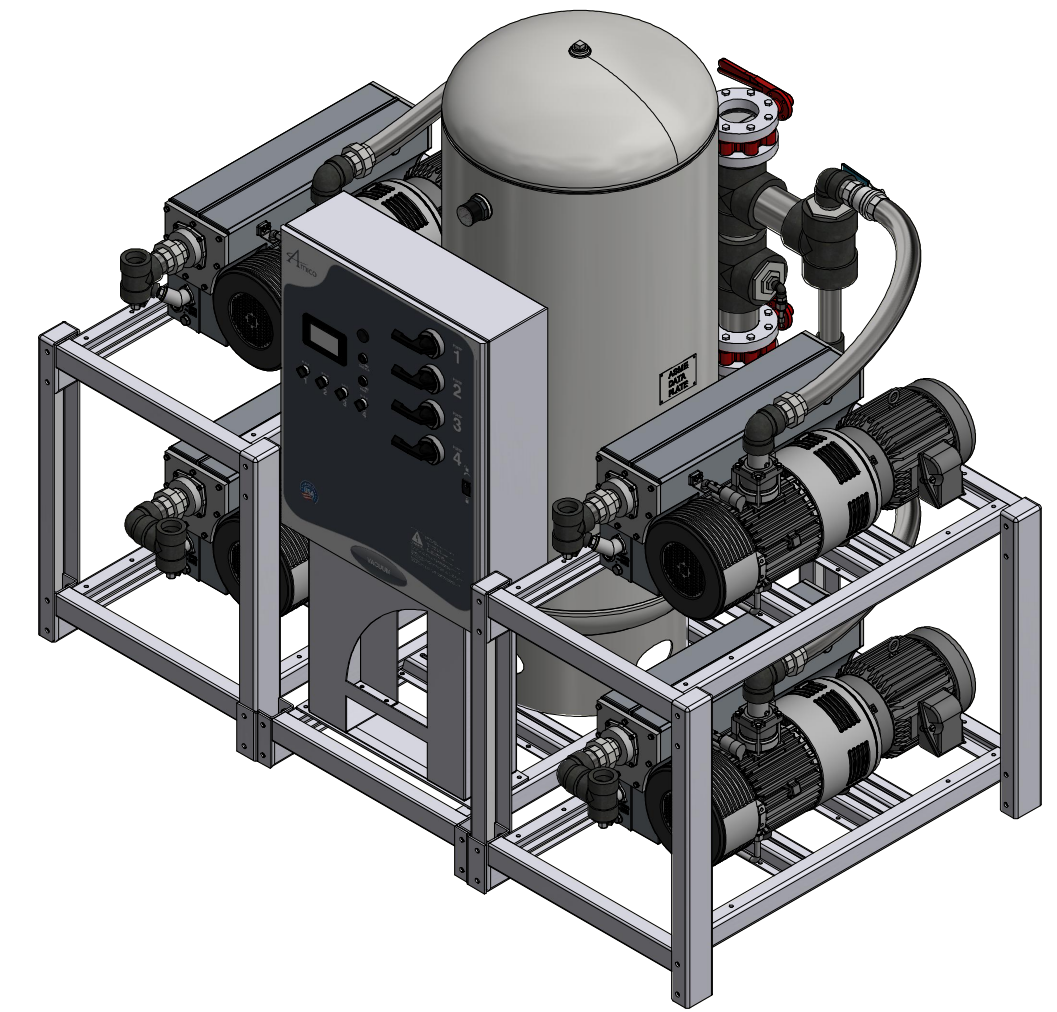
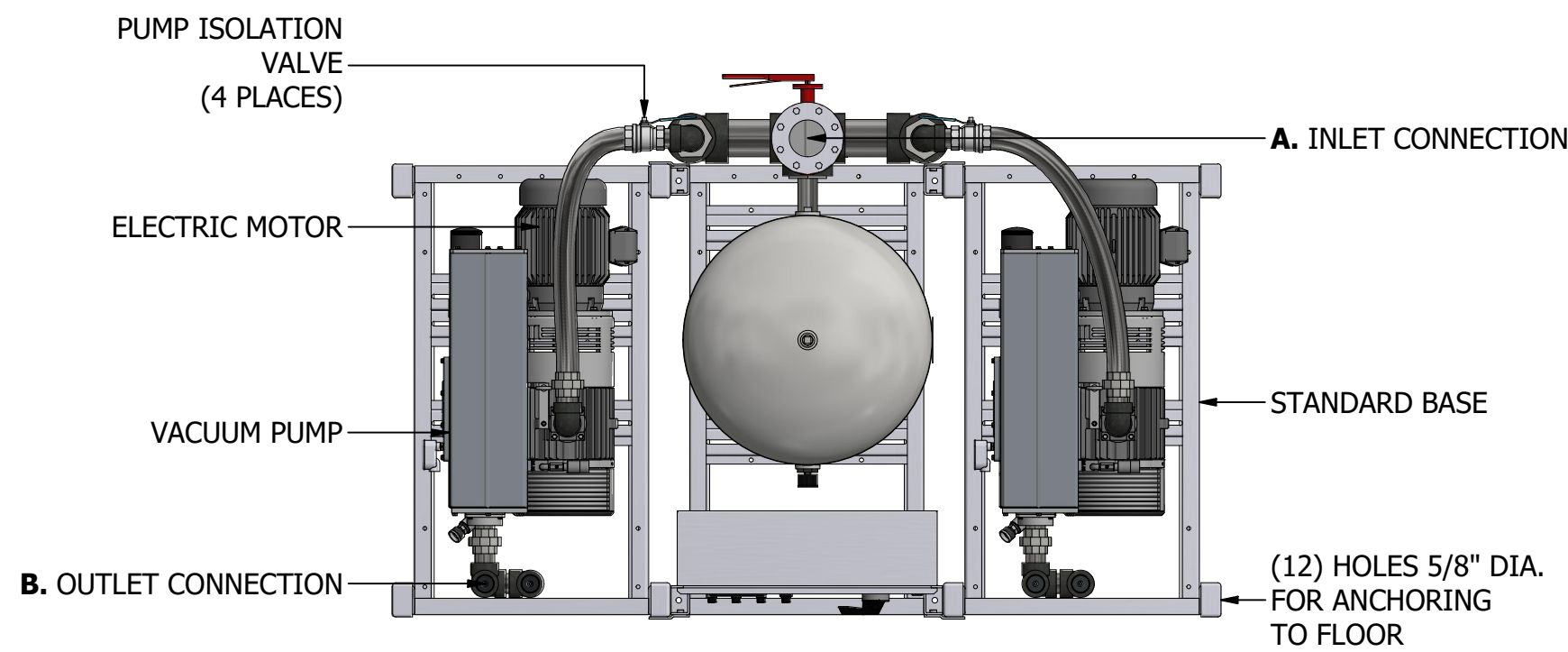

DIMENSIONS SUBJECT TO CHANGE WITHOUT NOTICE

MODEL	HP (KW)	A INLET NPT	B OUTLET NPT	TANK SIZE GALLON (LITRE)	PUMP SCFM @ 19" HG (LPM)		NFPA SYSTEM CAPACITIES WITH ONE COMPRESSOR ON STANDBY @ 19" HG (LPM)		WEIGHT IN LBS (KG)	SQ. FT. REQUIRED (M ²)	SYSTEM FLA (WITH ALL PUMPS RUNNING)				SYSTEM BTU/HR	SOUND LEVEL dB (A)	W (M)	L (M)	H (M)
					50 Hz Motor	60 Hz Motor	50 Hz Motor	60 Hz Motor			208V	230V	380V**	460V					
V-RVL-Q-200P-SS-N-010*	1 (0.75)	1.25	0.75	200 (757)	4.0 (113)	4.8 (136)	12.0 (340)	14.4 (408)	1735 (787)	38.6 (3.60)	18	18	10	10	7,632	71	101 (2.57)	55 (1.40)	91 (2.31)
V-RVL-Q-200P-SS-N-015*	1.5 (1.12)	2.0	1.25	200 (757)	5.8 (164)	7.0 (198)	17.4 (493)	21.0 (595)	2033 (922)	38.6 (3.60)	22	22	12	11	11,451	68	101 (2.57)	55 (1.40)	91 (2.31)
V-RVL-Q-200P-SS-N-020*	2 (1.49)	2.0	1.25	200 (757)	9.2 (261)	11.0 (311)	27.6 (782)	33.0 (934)	2089 (948)	38.6 (3.60)	26	26	15	13	15,267	71	101 (2.57)	55 (1.40)	91 (2.31)
V-RVL-Q-200P-SS-N-030*	3 (2.24)	2.0	1.25	200 (757)	14.2 (402)	17.0 (481)	42.6 (1206)	51.0 (1444)	2297 (1042)	38.6 (3.60)	38	35	20	18	22,899	71	101 (2.57)	55 (1.40)	91 (2.31)
V-RVL-Q-200P-SS-N-050	5 (3.73)	2.0	1.25	200 (757)	21.7 (614)	26.0 (736)	65.1 (1843)	78.0 (2209)	2401 (1089)	38.6 (3.60)	59	56	30	28	38,166	73	101 (2.57)	65 (1.65)	91 (2.31)
V-RVL-Q-200P-SS-N-052	5 (3.73)	4.0	2.0	200 (757)	30.8 (872)	37.0 (1048)	92.4 (2616)	111.0 (3143)	2629 (1192)	49.8 (4.63)	61	56	35	28	38,166	77	101 (2.57)	71 (1.80)	91 (2.31)
V-RVL-Q-200P-SS-N-075	7.5 (5.59)	4.0	2.0	200 (757)	43.3 (1226)	52.0 (1472)	129.9 (3678)	156.0 (4417)	3399 (1542)	49.8 (4.63)	91	90	48	46	57,249	79	101 (2.57)	71 (1.80)	91 (2.31)
V-RVL-Q-200P-SS-N-100	10 (7.46)	4.0	2.0	200 (757)	54.2 (1535)	65.0 (1841)	162.6 (4604)	195.0 (5522)	3499 (1587)	49.8 (4.63)	112	109	55	54	76,332	79	101 (2.57)	71 (1.80)	91 (2.31)
V-RVL-Q-200P-SS-N-101	10 (7.46)	4.0	2.0	200 (757)	64.2 (1818)	77.0 (2180)	192.6 (5454)	231.0 (6541)	3959 (1796)	49.8 (4.63)	112	109	55	54	76,332	81	101 (2.57)	71 (1.80)	91 (2.31)
V-RVL-Q-200P-SS-N-150*	15 (11.2)	4.0	3.0	200 (757)	92.5 (2619)	111.0 (3143)	277.5 (7858)	333.0 (9429)	6478 (2938)	76.7 (7.13)	204	154	91	80	114,498	84	138 (3.51)	80 (2.03)	93 (2.36)
V-RVL-Q-200P-SS-N-200*	20 (14.9)	4.0	3.0	200 (757)	114.2 (3234)	137.0 (3879)	342.6 (9701)	411.0 (11638)	7232 (3280)	76.7 (7.13)	252	212	114	106	152,667	84	138 (3.51)	80 (2.03)	93 (2.36)
V-RVL-Q-200P-SS-N-250*	25 (18.6)	4.0	3.0	200 (757)	140.0 (3964)	168.0 (4757)	420.0 (11893)	504.0 (14272)	8106 (3677)	76.7 (7.13)	276	252	150	126	190,833	84	138 (3.51)	80 (2.03)	93 (2.36)

*SYSTEM CONFIGURATION DIFFERS FROM MODEL SHOWN

**380 VOLT DATA PROVIDED AT 50HZ
ALL OTHER VOLTAGES ARE RATED AT 60HZ

ADDITIONAL MODELS AVAILABLE UPON REQUEST



600 Prime Place, Hauppauge
NY 11788, USA
Direct Tel: 905.764.0800
Tel: 1.877.462.6426
Fax: 1.866.440.4986