

LAB ROTARY VANE - DRY DUPLEX STACK MOUNTED VACUUM SYSTEM (0.5 HP - 8.9 HP)

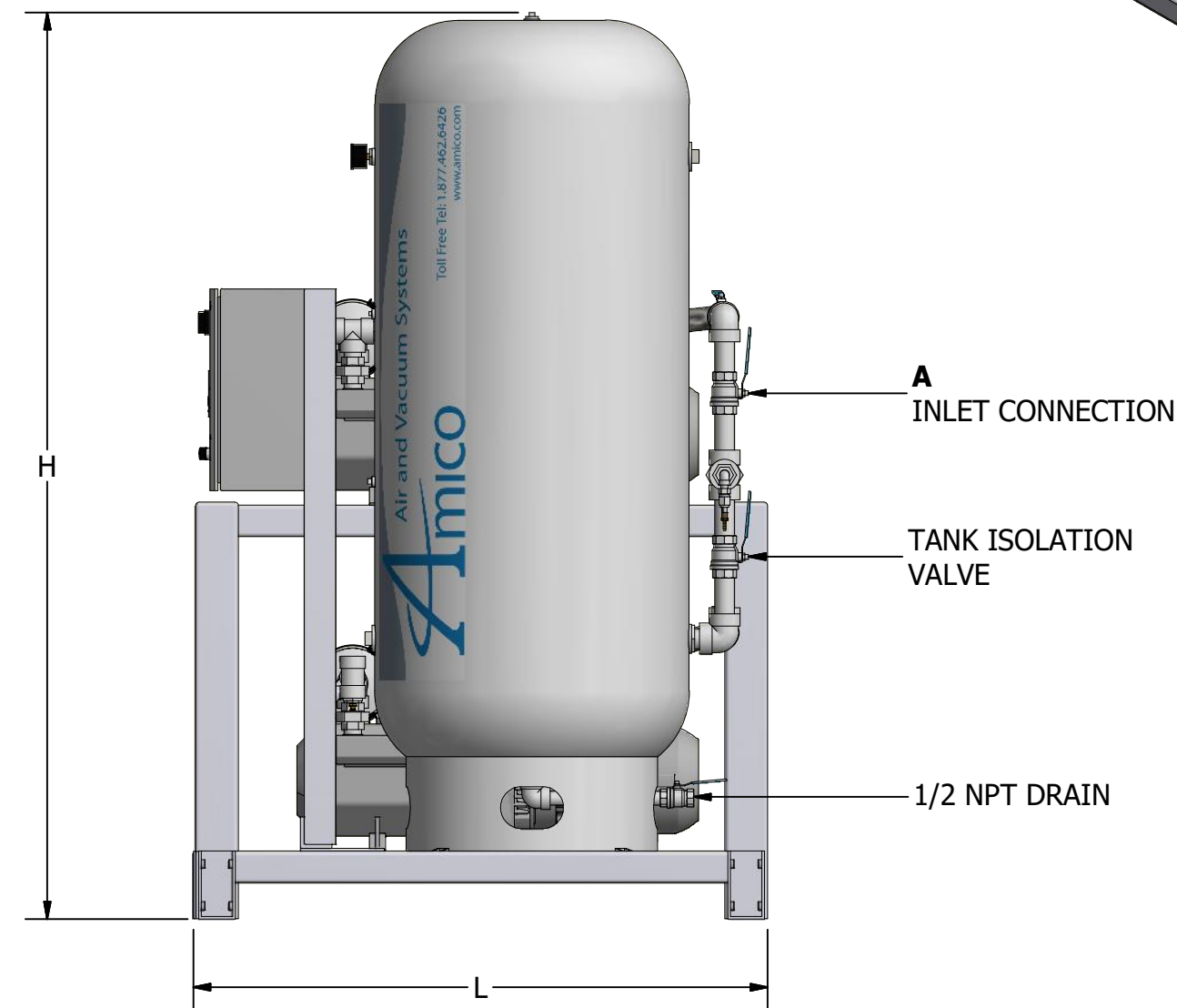
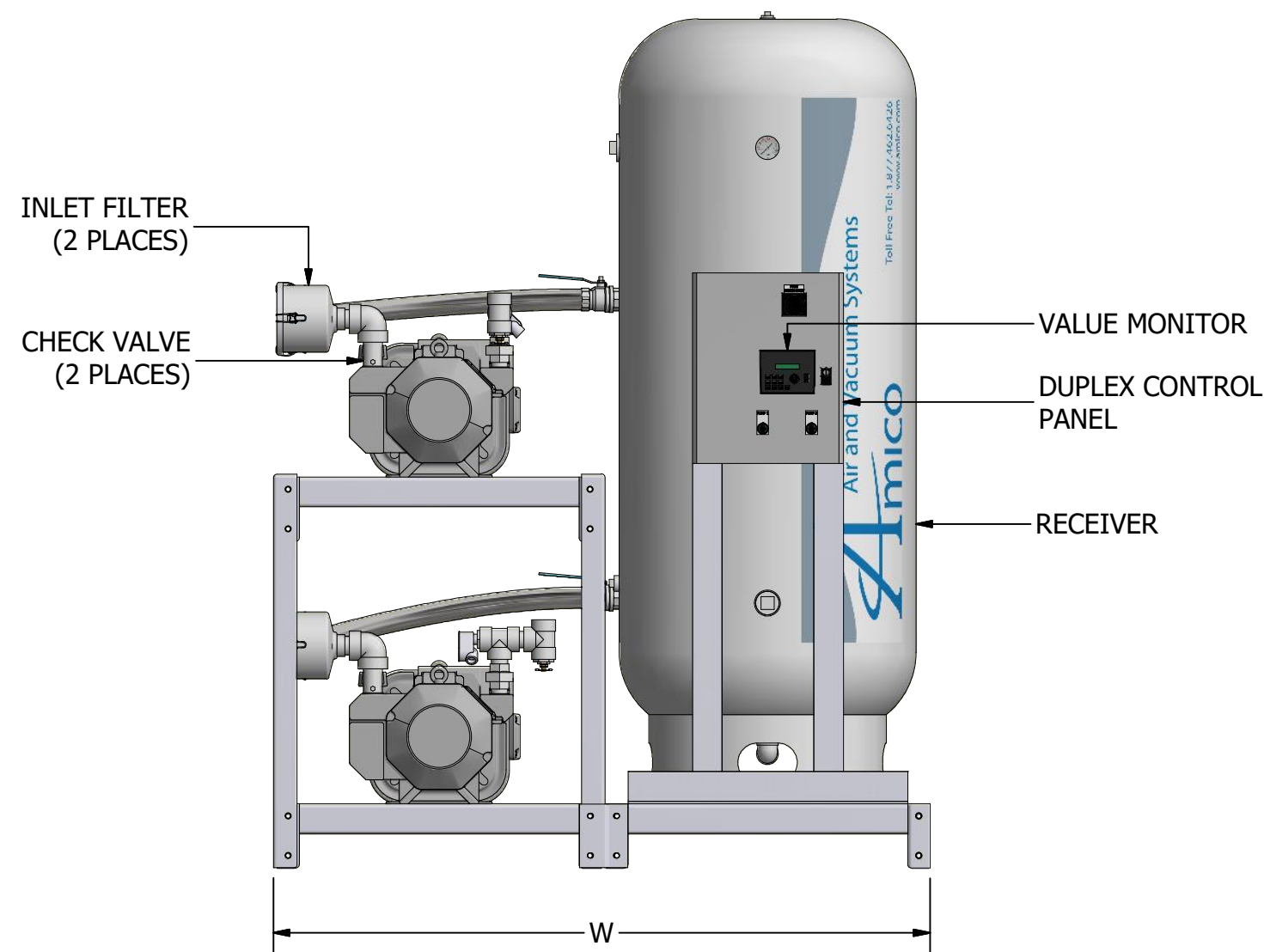
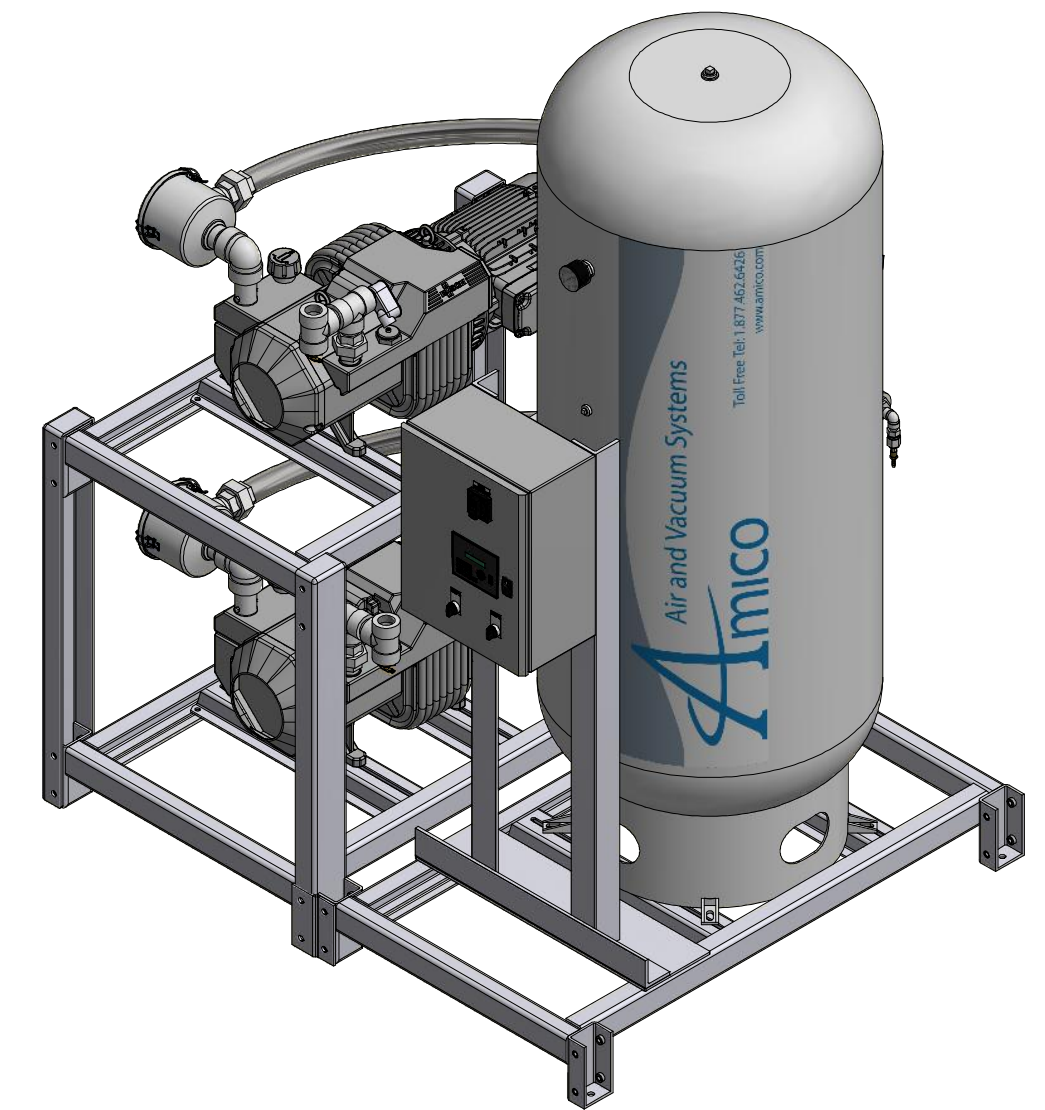
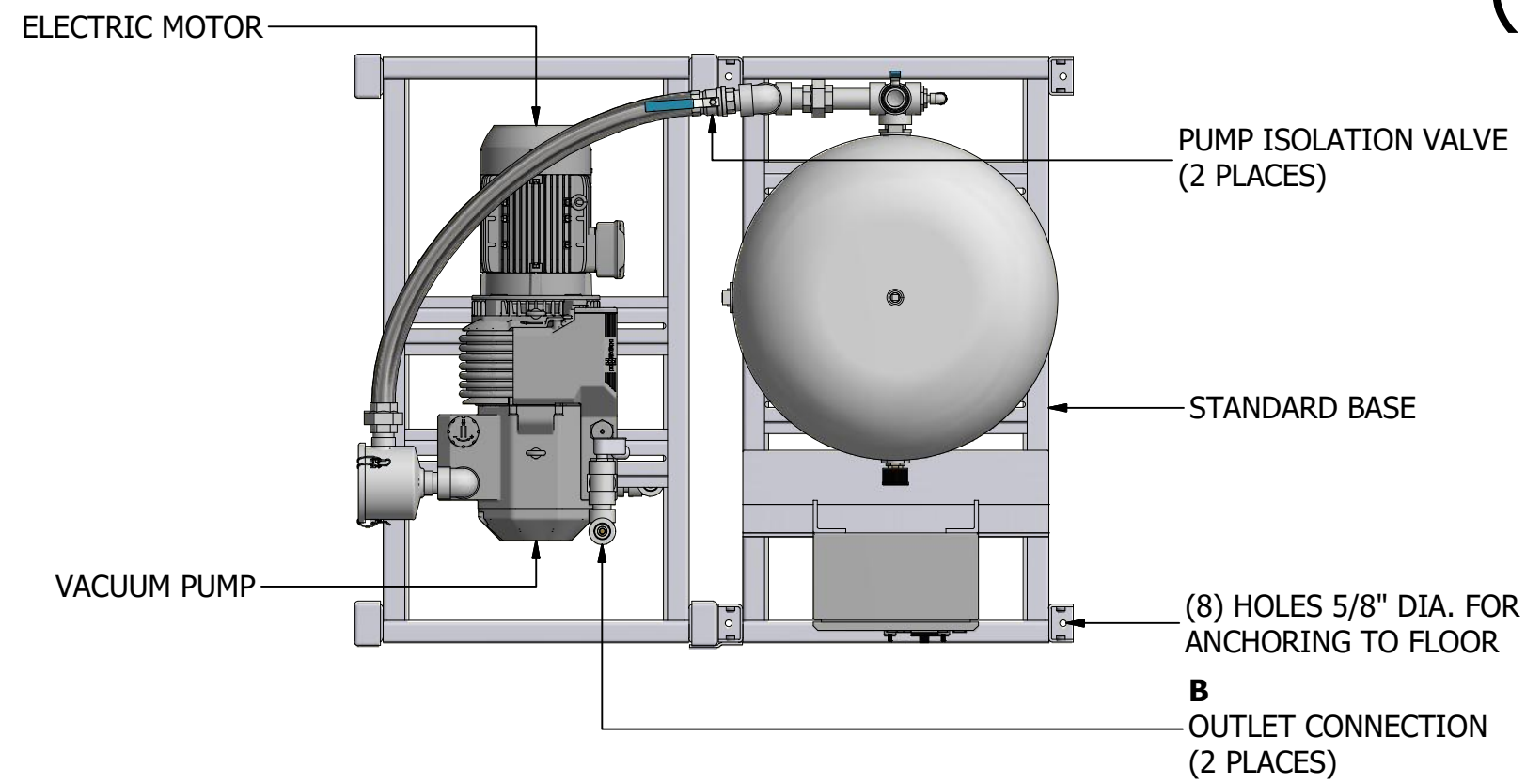

DIMENSIONS SUBJECT TO CHANGE WITHOUT NOTICE

*SYSTEM CONFIGURATION DIFFERS FROM MODEL SHOWN

**380 VOLT DATA PROVIDED AT 50HZ
ALL OTHER VOLTAGES ARE RATED AT 60HZ

ADDITIONAL MODELS AVAILABLE UPON REQUEST

MODEL	HP (KW)	A INLET NPT	B OUTLET NPT	TANK SIZE GALLON (LITRE)	PUMP SCFM @ 19" HG (LPM)		SYSTEM CAPACITIES @ 19" HG (LPM)		WEIGHT IN LBS (KG)	SQ. FT. REQUIRED (M ²)	SYSTEM FLA (WITH ALL PUMPS RUNNING)				SYSTEM BTU/HR	SOUND LEVEL dB (A)	W (M)	L (M)	H (M)
					50 Hz Motor	60 Hz Motor	50 Hz Motor	60 Hz Motor			208V	230V	380V**	460V					
V-RVD-D-200P-SS-L-005*	0.5 (0.37)	0.5	1.0	200 (757)	2.0 (57)	2.4 (68)	4.0 (113)	4.8 (136)	1289 (585)	25.6 (2.38)	6	6	4	3	2,544	65	67 (1.70)	55 (1.40)	91 (2.31)
V-RVD-D-200P-SS-L-007*	0.75 (0.56)	0.5	1.0	200 (757)	2.8 (79)	3.4 (96)	5.6 (159)	6.8 (193)	1307 (593)	25.6 (2.38)	9	8	5	4	3,816	66	67 (1.70)	55 (1.40)	91 (2.31)
V-RVD-D-200P-SS-L-012*	1.2 (0.89)	0.75	1.0	200 (757)	4.4 (125)	5.3 (150)	8.8 (249)	10.6 (300)	1333 (605)	25.6 (2.38)	12	12	7	7	6,106	69	67 (1.70)	55 (1.40)	91 (2.31)
V-RVD-D-200P-SS-L-017*	1.7 (1.27)	0.75	1.0	200 (757)	6.7 (190)	8.0 (227)	13.4 (379)	16.0 (453)	1365 (619)	25.6 (2.38)	16	15	8	8	8,652	73	67 (1.70)	55 (1.40)	91 (2.31)
V-RVD-D-200P-SS-L-032*	3.2 (2.39)	1.25	1.25	200 (757)	11.3 (320)	13.5 (382)	22.6 (640)	27.0 (765)	1559 (707)	25.6 (2.38)	20	18	9	9	16,284	79	67 (1.70)	55 (1.40)	91 (2.31)
V-RVD-D-200P-SS-L-046*	4.6 (3.43)	1.25	1.25	200 (757)	14.2 (402)	17.0 (481)	28.4 (804)	34.0 (963)	1593 (723)	25.6 (2.38)	-	27	13	13	23,408	80	67 (1.70)	55 (1.40)	91 (2.31)
V-RVD-D-200P-SS-L-056*	5.6 (4.18)	1.25	1.25	200 (757)	17.5 (496)	21.0 (595)	35.0 (991)	42.0 (1189)	1727 (783)	25.6 (2.38)	33	32	17	16	28,498	79	67 (1.70)	55 (1.40)	91 (2.31)
V-RVD-D-200P-SS-L-089	8.9 (6.64)	1.5	1.5	200 (757)	23.3 (660)	28.0 (793)	46.6 (1320)	56.0 (1586)	1793 (813)	25.6 (2.38)	51	49	25	25	45,290	80	67 (1.70)	55 (1.40)	91 (2.31)



85 Fulton Way, Richmond Hill
Ontario, L4B 2N4 Canada
71 East Industry Court
Deer Park, NY 11729
Direct Tel: 905.764.0800
Tel: 1.877.462.6426
Fax: 1.866.440.4986