

DUPLEX RECIPROCATING AIR PLANT WITH DESICCANT AIR TREATMENT SYSTEM (1.0 HP - 5.0 HP)

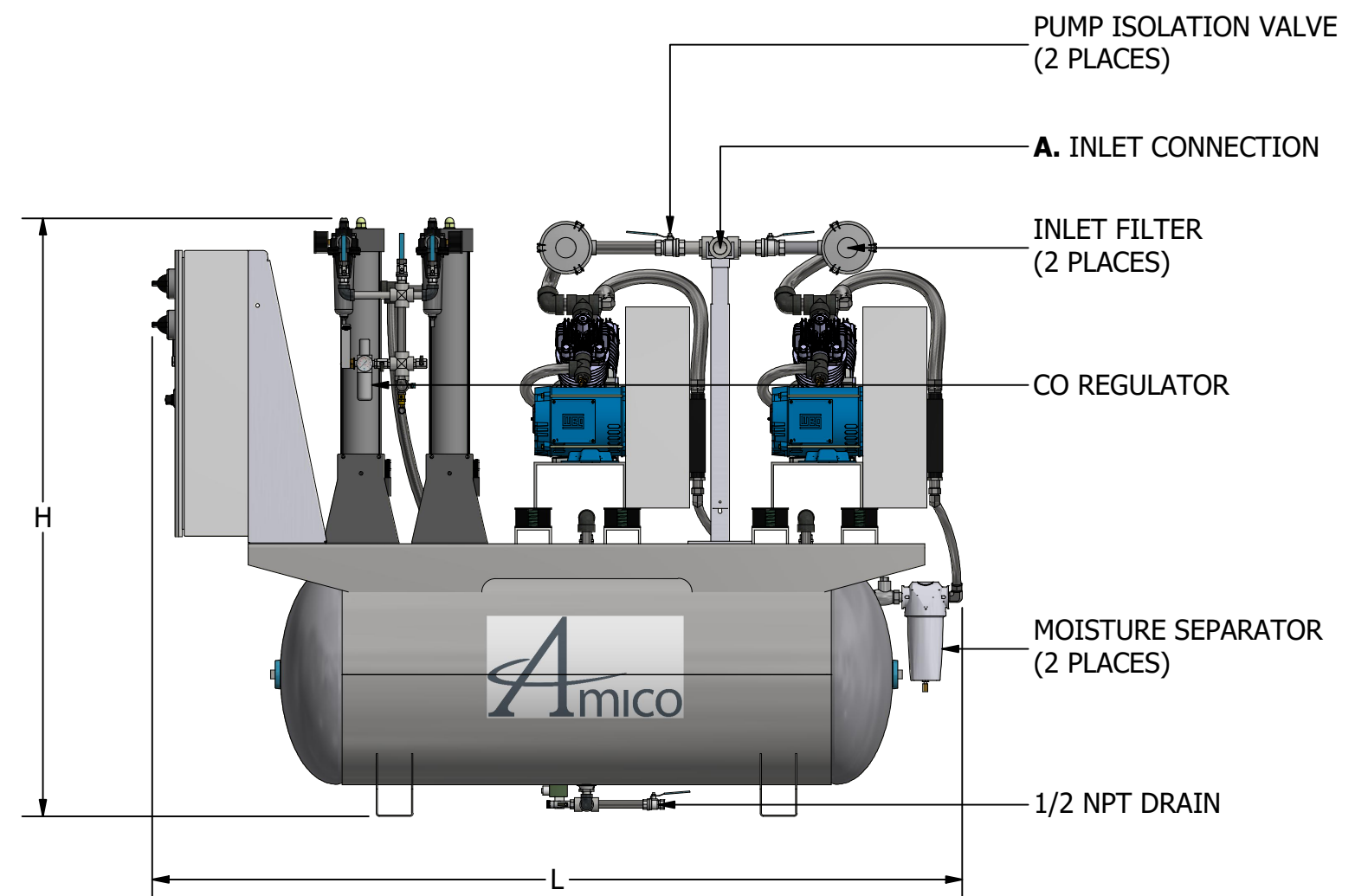
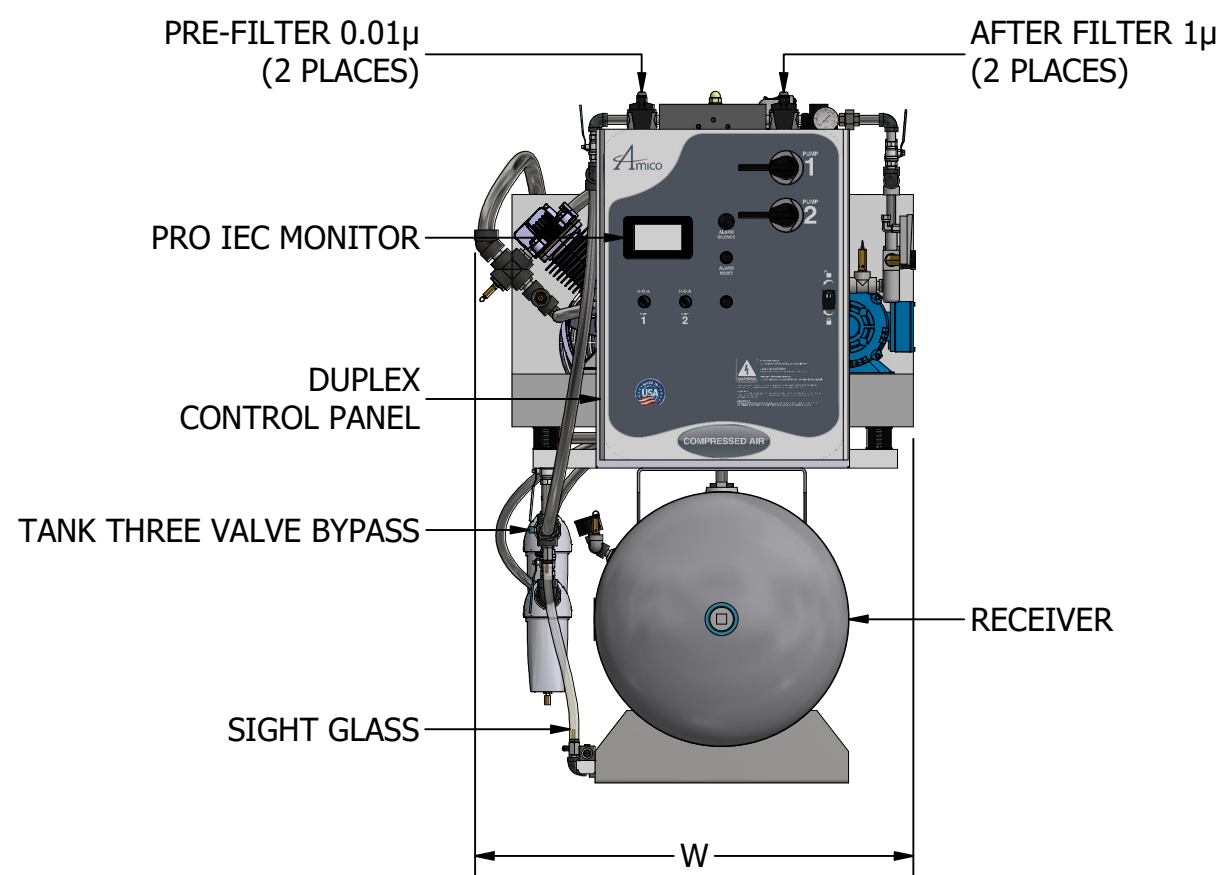
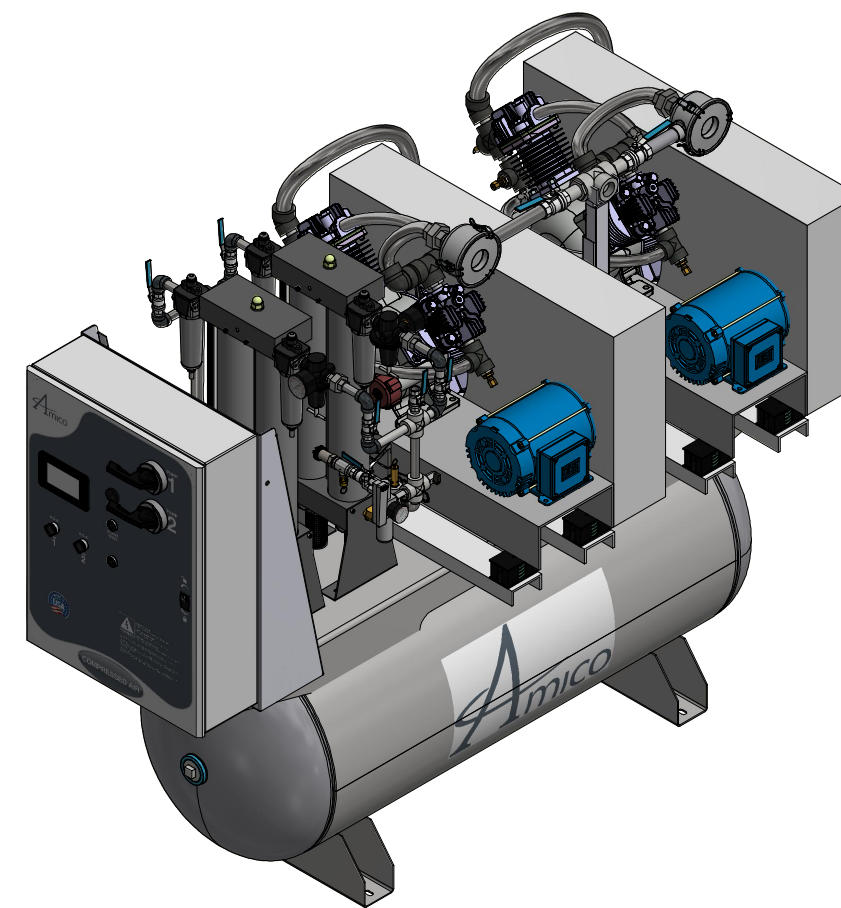
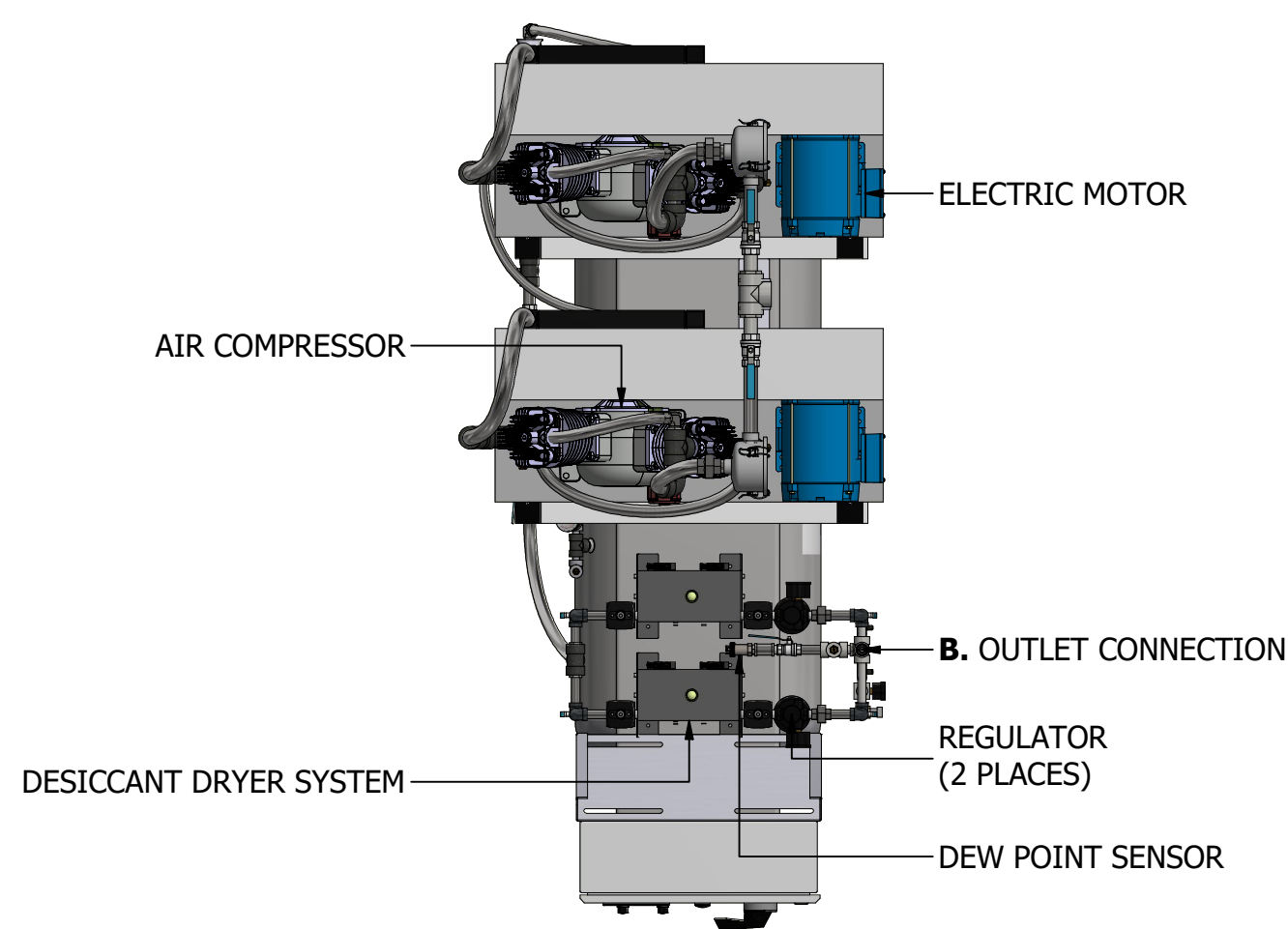

*SYSTEM CONFIGURATION DIFFERS FROM MODEL SHOWN

**380 VOLT DATA PROVIDED AT 50HZ
ALL OTHER VOTAGES ARE RATED AT 60HZ

DIMENSIONS SUBJECT TO CHANGE WITHOUT NOTICE

ADDITIONAL MODELS AVAILABLE UPON REQUEST

MODEL	HP (KW)	A INLET NPT	B OUTLET NPT	TANK SIZE GALLON (LITRE)	COMPRESSOR SCFM (LPM)		NFPA SYSTEM CAPACITIES WITH ONE COMPRESSOR ON STANDBY (LPM)		WEIGHT IN LBS (KG)	SQ. FT. REQUIRED (M ²)	SYSTEM FLA (WITH ALL COMPRESSORS RUNNING)				SYSTEM BTU/HR	SOUND LEVEL dB (A)	W (M)	L (M)	H (M)
					@ 50 psig	@ 100 psig	@ 50 psig	@ 100 psig			208V	230V	380V**	460V					
A-RED-D-120P-TH-N-010*	1 (0.75)	1.25	0.5	120 (454)	4.1 (116)	3.3 (93)	4.1 (116)	3.3 (93)	1095 (497)	23.6 (2.20)	10	10	6	5	2,544	72	37 (0.94)	92 (2.34)	73 (1.85)
A-RED-D-120P-TH-N-020*	2 (1.49)	1.25	0.5	120 (454)	7.8 (221)	6.6 (187)	7.8 (221)	6.6 (187)	1155 (524)	23.6 (2.20)	13	11	6	6	5,089	73	37 (0.94)	92 (2.34)	73 (1.85)
A-RED-D-120P-TH-N-030*	3 (2.24)	1.25	0.5	120 (454)	10.1 (286)	9.4 (266)	10.1 (286)	9.4 (266)	1239 (562)	25.6 (2.39)	15	14	8	7	7,633	74	40 (1.02)	92 (2.34)	73 (1.85)
A-RED-D-120P-TH-N-050	5 (3.73)	1.25	0.5	120 (454)	18.4 (521)	15.4 (436)	18.4 (521)	15.4 (436)	1399 (635)	28.8 (2.67)	21	18	11	9	12,722	76	45 (1.14)	92 (2.34)	68 (1.73)



600 Prime Place, Hauppauge
NY 11788, USA
Direct Tel: 905.764.0800
Tel: 1.877.462.6426
Fax: 1.866.440.4986