

DUPLEX SCROLL AIR PLANT WITH DESICCANT AIR TREATMENT SYSTEM (2.0 HP - 10.0 HP)

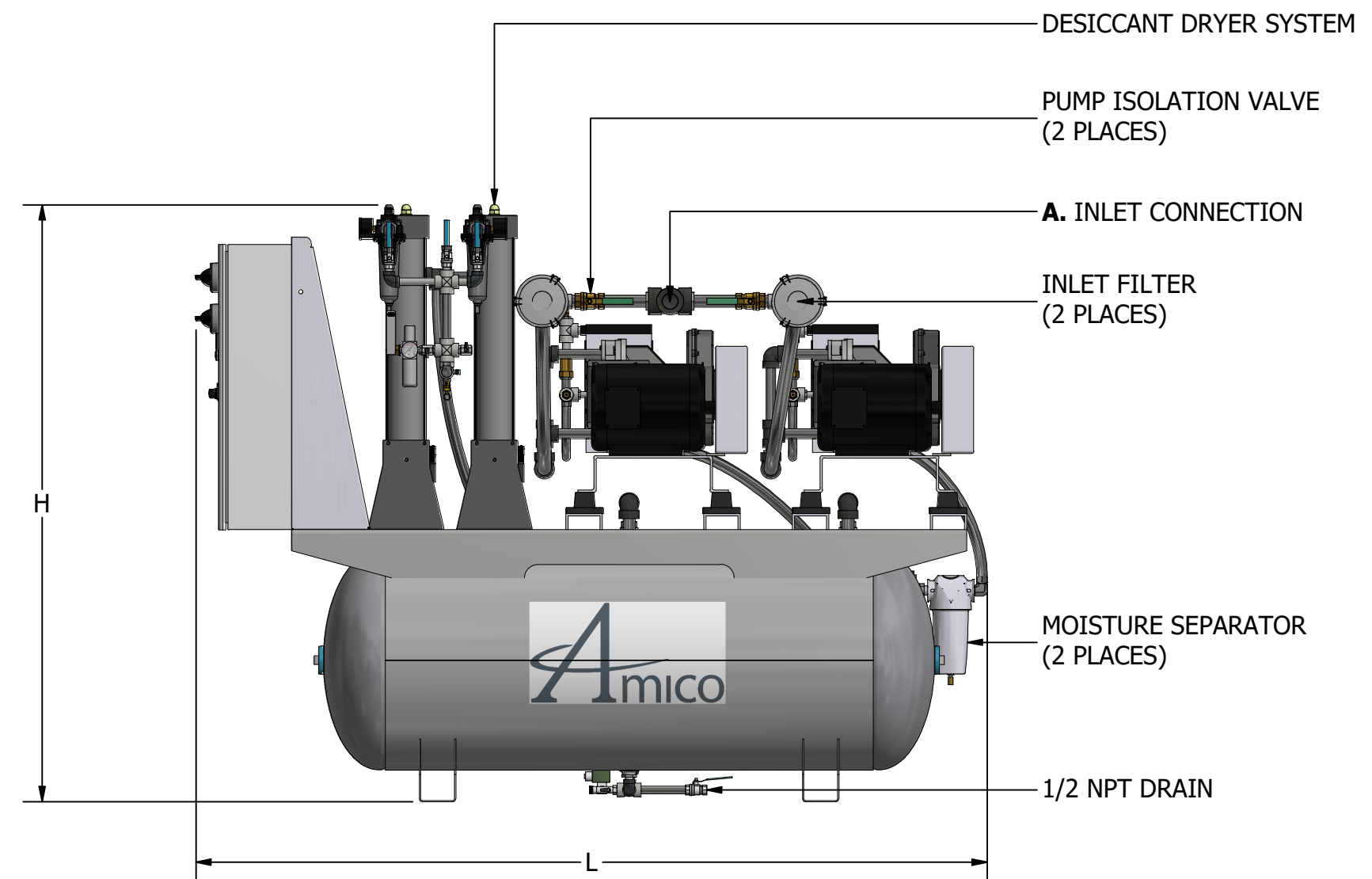
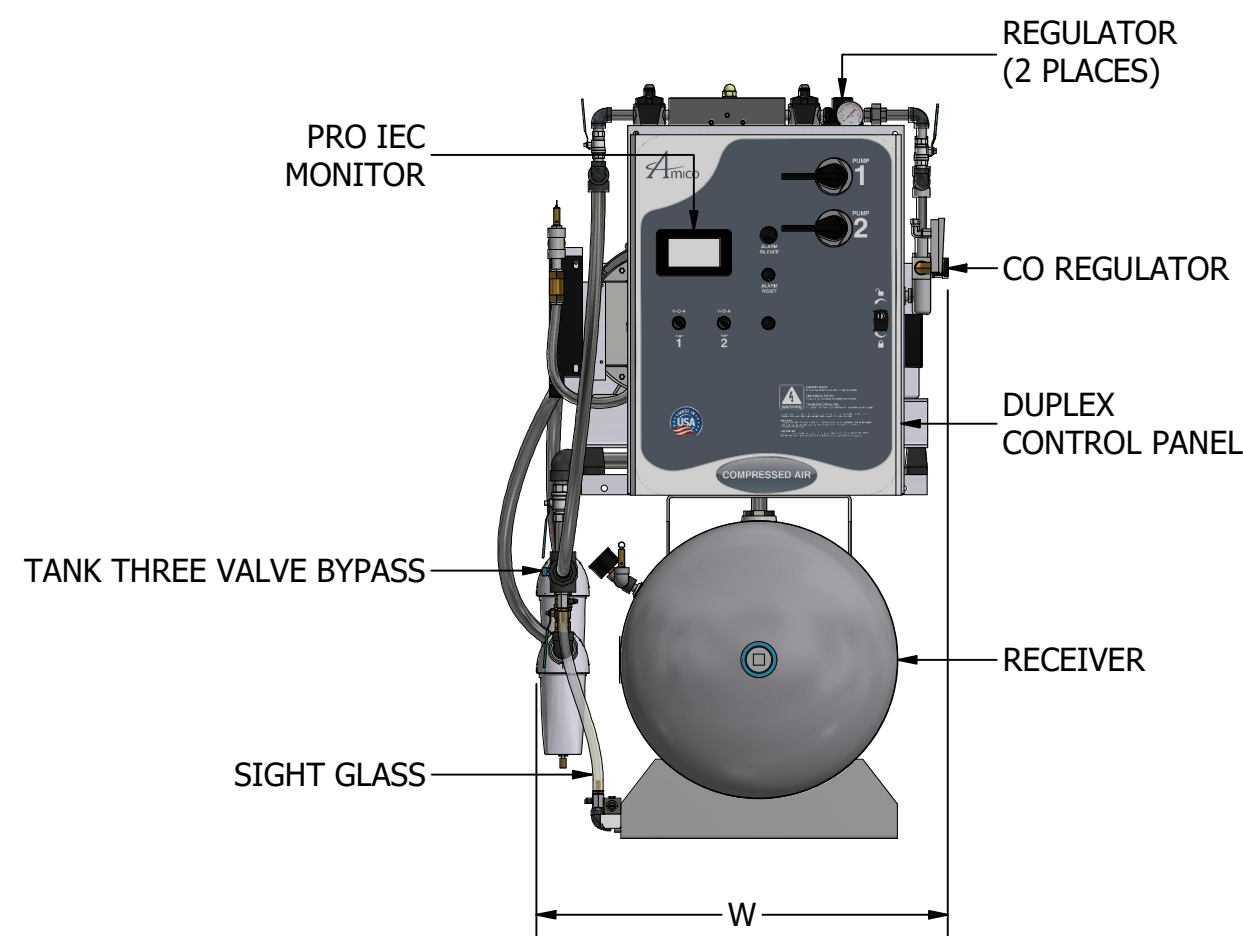
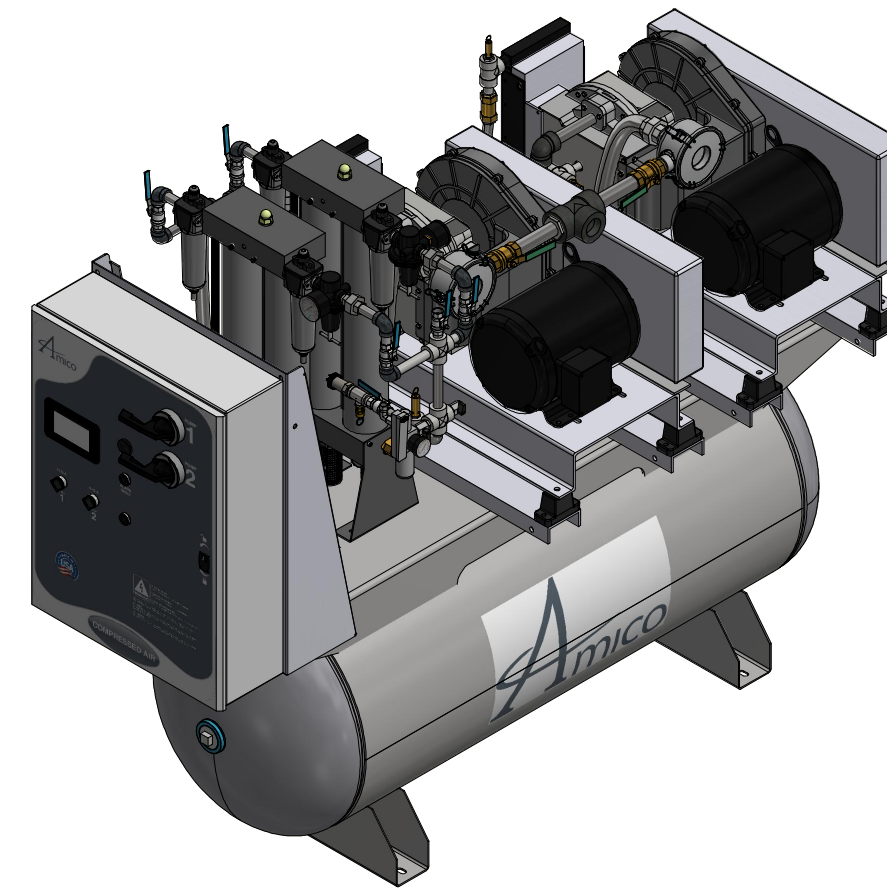
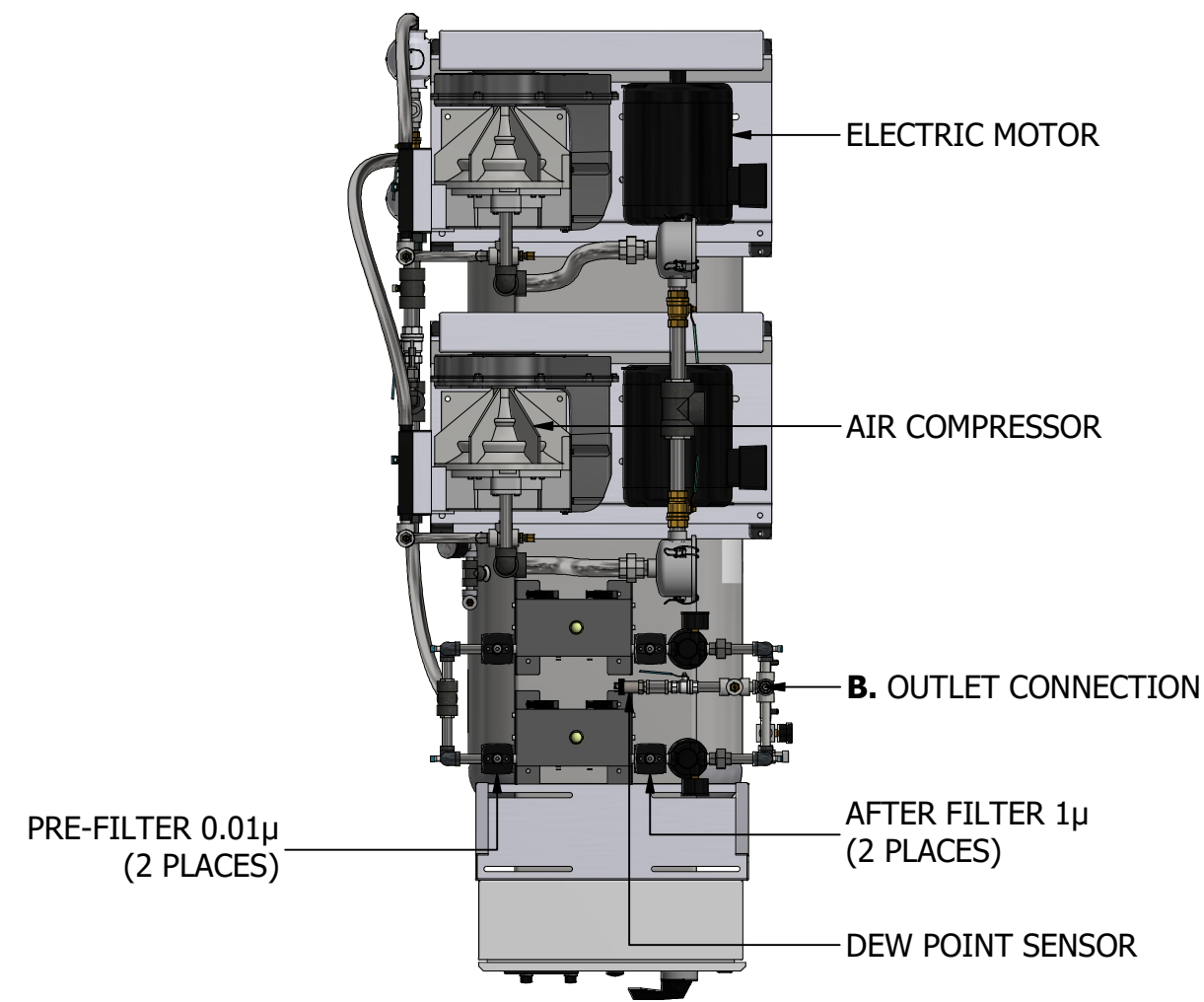

DIMENSIONS SUBJECT TO CHANGE WITHOUT NOTICE

*SYSTEM CONFIGURATION DIFFERS FROM MODEL SHOWN

**380 VOLT DATA PROVIDED AT 50HZ
ALL OTHER VOLTAGES ARE RATED AT 60HZ

ADDITIONAL MODELS AVAILABLE UPON REQUEST

MODEL	HP (kW)	A INLET NPT	B OUTLET NPT	TANK SIZE GALLON (LITRE)	COMPRESSOR SCFM (LPM)		NFPA SYSTEM CAPACITIES WITH ONE COMPRESSOR ON STANDBY (LPM)		WEIGHT IN LBS (KG)	SQ. FT. REQUIRED (M ²)	SYSTEM FLA (WITH ALL COMPRESSORS RUNNING)				SYSTEM BTU/HR	SOUND LEVEL dB (A)	W (M)	L (M)	H (M)
					@ 50 psig	@ 120 psig	@ 50 psig	@ 120 psig			208V	230V	380V**	460V					
A-SCD-D-080P-TH-N-020	2 (1.49)	1.0	0.5	80 (303)	6.2 (176)	5.6 (159)	6.2 (176)	5.6 (159)	1435 (651)	24.6 (2.29)	15	14	8	7	5,089	74	39 (0.99)	91 (2.31)	69 (1.75)
A-SCD-D-080P-TH-N-030	3 (2.24)	1.0	0.5	80 (303)	9.2 (261)	8.5 (241)	9.2 (261)	8.5 (241)	1435 (651)	24.6 (2.29)	21	18	11	9	7,633	74	39 (0.99)	91 (2.31)	69 (1.75)
A-SCD-D-120P-TH-N-050	5 (3.73)	1.5	0.5	120 (454)	15.2 (430)	14.1 (399)	15.2 (430)	14.1 (399)	1789 (811)	25.6 (2.39)	32	28	17	14	12,722	74	40 (1.02)	92 (2.34)	69 (1.75)
A-SCD-D-120P-TH-N-075	7.5 (5.59)	1.5	0.5	120 (454)	25.2 (714)	24.0 (680)	25.2 (714)	24.0 (680)	1831 (931)	29.0 (2.68)	44	39	23	19	19,083	74	43 (1.09)	97 (2.46)	79 (2.01)
A-SCD-D-120P-TH-N-100	10 (7.46)	1.5	0.5	120 (454)	34.8 (985)	32.0 (906)	34.8 (985)	32.0 (906)	1933 (877)	29.0 (2.68)	57	52	31	26	25,444	74	43 (1.09)	97 (2.46)	79 (2.01)



600 Prime Place, Hauppauge
NY 11788, USA
Direct Tel: 905.764.0800
Tel: 1.877.462.6426
Fax: 1.866.440.4986